

BALDOR • RELIANCE

Customer information packet

CPX36746T

75//60HP, 1780//1480RPM, 3PH, 60//50HZ, 365T

Class - CLI GP C,D; CLII GP E,F,G

Division - Division I

Specifications

Enclosure	TEFC
Frame	365T
Frame Material	Iron
Frequency	60.00 Hz
Motor Letter Type	Three Phase
Output @ Frequency	75.000 HP @ 60 HZ
Phase	3
Synchronous Speed @ Frequency	1800 RPM @ 60 HZ
Voltage @ Frequency	230.0 V @ 60 HZ 460.0 V @ 60 HZ
XP Class and Group	CLI GP C,D; CLII GP E,F,G
XP Division	Division I
Agency Approvals	CCSA US CSA CSA EEV UL
Ambient Temperature	40 °C
Auxillary Box	No Auxillary Box
Base Indicator	Rigid
Bearing Grease Type	Polyrex EM (-20F +300F)
Constant Torque Speed Range	10-60
Current @ Voltage	86.000 A @ 460.0 V 172.000 A @ 230.0 V
Design Code	B
Drip Cover	No Drip Cover
Duty Rating	CONT
Efficiency @ 100% Load	95.4 %
Enclosure Modification	Severe Duty Features
Feedback Device	NO FEEDBACK
Heater Indicator	No Heater
High Voltage Full Load Amps	86.0 a
Insulation Class	F

Part detail

Revision	E
Type	AC
Mech. spec.	
Base	
Status	PRD/A
Elec. spec.	A36WG1512
Layout	616512-505
Eff. date	12-03-2021
CD Diagram	416820-002
Poles	04
Leads	3#4,6#6
Proprietary	False
Created date	02-07-2019

Inverter Code	Inverter Ready
IP Rating	IP55
KVA Code	G
Lifting Lugs	Standard Lifting Lugs
Max Speed	3600 rpm
Motor Lead Quantity/Wire Size	3 @ 4 AWG
Motor Standards	NEMA
Motor Type	A36070M
Mounting Arrangement	F1
Number of Poles	4
Overall Length	33.48 IN
Power Factor	86
Product Family	General Industrial
Pulley End Bearing Type	Ball
Pulley Face Code	Standard
Service Factor	1.15
Shaft Diameter	2.374 IN
Shaft Ground Indicator	No Shaft Grounding
Shaft Rotation	Reversible
Shaft Slinger Indicator	Shaft Slinger
Speed	1780 rpm
Speed Code	Single Speed
Starting Method	Direct on line
Thermal Device - Bearing	None
Thermal Device - Winding	Normally Closed Thermostat
XP Temp Code	T3C

Nameplate

NP2496L	
MOBIL POLYREX EM	

000613006PC

CLASS I GROUP C D X **NO.****CLASS II GROUP** E F G**OPERATING TEMP CODE** T3C

000901002AAA

SUIT @ 55C AMB AT 1.00 SF AT S	INEWAVE

NP3140L

SPEC NO.	A36-7732-1512	CAT.NO.	CPX36746T	FRAME	365T
HP	75	VOLTS	230/460	PHASE	3
RPM	1780	AMPS	172/86	HZ	60
DRIVE END BEARING	65BC03J30X	DUTY	CONT	INSUL.CLASS	F
OPP D.E. BEARING	65BC03J30X	ENCL	TEFC	CODE	G
SF	1.15	WK2	14.02	MAG CUR	27.6
CT HZ	10-60	VT HZ	0-60	CHP HZ	60-90
	IP66			RPM MAX	3600
SER.NO.		MOTOR WEIGHT		NEMA-NOM-EFF	95.4

Parts list

Part number	Description	Quantity
SA365904	SA A36-7732-1512	1.000 ea
RA355309	RA A36-7732-1512	1.000 ea
421948032	LABEL, MYLAR	1.000 ea
NP2496L	MOTOR LUBE NAMEPLATE	1.000 ea
000692000VD	LABEL WARNING	1.000 ea
LB1073	ALUM XP CAUTION LABEL	1.000 ea
000613006PC	N/P U/L (REL QTY 500)	1.000 ea
000901002AAA	N/P BLANK (RELEASE QTY 1,500)	1.000 ea
NP3140L	INVERTER DUTY, SS, CC, CSA-C US, CSA EEV	1.000 ea
609158001B	SLGR - 360	1.000 ea
603284001S	SLGR - 360	1.000 ea
087793060BB	BRKT 360 087793050WCB	1.000 ea
415072001B	CLAMP	1.000 ea
415030051AX	BUSH - 360	1.000 ea
078559001A	+FANCV - 360	1.000 ea
034180012DA	KEY 1X4X1/4X1-1/2 L	1.000 ea
702676001C	FAN 360	1.000 ea
004824015A	GREASE POLYREX EM	0.540 lb
032018008AK	HHCS 1/4-20X1 PLATED	4.000 ea
032018018CK	HHCS 3/8-16X2-1/4 PLTD.	2.000 ea
415096002A	CPLG 1/8 HEX TYPE	1.000 ea
604923009R	SLGR - 360	1.000 ea
410700004F	WSHR	1.000 ea
034017016AB	LCKW 1/2" PLATED	4.000 ea
034017012AB	LCKW 1/4 STD. PLATED 034017012AF	4.000 ea
032130020DB	HSHCS 1/2-13X2-1/2 PLTD.	4.000 ea
034017014AB	LCKW 3/8 STD. PLATED	2.000 ea
034530056AC	P/NIP 1/8X7L GALV-365	1.000 ea
032620012HD	HSSS 8-32X3/8 304S.S.	2.000 ea
034690002AB	PPLG 1/4" PLTD.	1.000 ea
034690002AB	PPLG 1/4" PLTD.	1.000 ea

087793113	BRKT STD 313 E360 FCXP W/ CL.II GRP E &	1.000 ea
032018018CK	HHCS 3/8-16X2-1/4 PLTD.	2.000 ea
604923009R	SLGR - 360	1.000 ea
034017016AB	LCKW 1/2" PLATED	4.000 ea
034017014AB	LCKW 3/8 STD. PLATED	2.000 ea
032620012HD	HSSS 8-32X3/8 304S.S.	2.000 ea
404478000CC	BRDRN (180-280)	1.000 ea
034530020AB	P/NIP 1/8X2-1/2 PLTED	1.000 ea
415096002A	CPLG 1/8 HEX TYPE	1.000 ea
415030051AX	BUSH - 360	1.000 ea
032130020DB	HSHCS 1/2-13X2-1/2 PLTD.	4.000 ea
16CB1001A01	CONDUIT BOX MACH GRP C MTRS 16CB1001	1.000 ea
16CB1501A01	CONDUIT BOX LID MACH.GRP C MTRS 16CB1501	1.000 ea
418150003A	GREASE FITTING CAP	1.000 ea
034017018AB	5/8 MED LOCK WASHER ZP (034017018AF)	8.000 ea
034017014AB	LCKW 3/8 STD. PLATED	4.000 ea
035000001A	ALFTG 1/8" 1610-BL	1.000 ea
032130016EB	HSHCS 5/8-11X2 PLTD.	8.000 ea
047024002J	TERMINAL LUG - MAKE FROM 047024002F	1.000 ea
406099000A	PLUG - FAN COVER 320-440	1.000 ea
032018008DK	HHCS 1/2-13X1 PLATED	1.000 ea
034017016AB	LCKW 1/2" PLATED	1.000 ea
032130014CB	HSHCS 3/8-16X1-3/4 PLTD.	4.000 ea
035000001A	ALFTG 1/8" 1610-BL	1.000 ea
418150003A	GREASE FITTING CAP	1.000 ea
MG1025G29	WILKOFAS, 789.229, DARK CHARCOAL GRAY	0.250 ga
033775004EA	DRSCR #6-1/4 304 S.S.	8.000 ea
034180034HA	KEY 5/8X5/8X4-1/4 L	1.000 ea
14PA1000	PACKAGING 314 GROUP COMBINED PRINT	1.000 ea
HW1000A32	5/16 FL WASHER WIDE,ID=.344,OD=1.125	3.000 ea
032509020C	CARRIAGE BOLT - 360	3.000 ea

DUTY MASTER ALTERNATING CURRENT MOTORS

616512-505

SQUIRREL-CAGE INDUCTION

ENCLOSURE: TOTALLY ENCLOSED

FRAME 365T

COOLING: FAN-COOLED

MOUNTING: FOOT, F-1 SIDE

INCLUDES 364T FRAME MOUNTING HOLES
CLASS 1 GROUP C&D / CLASS 2 GROUP E,F & G
WITH TACONITE SEAL BOTH ENDS

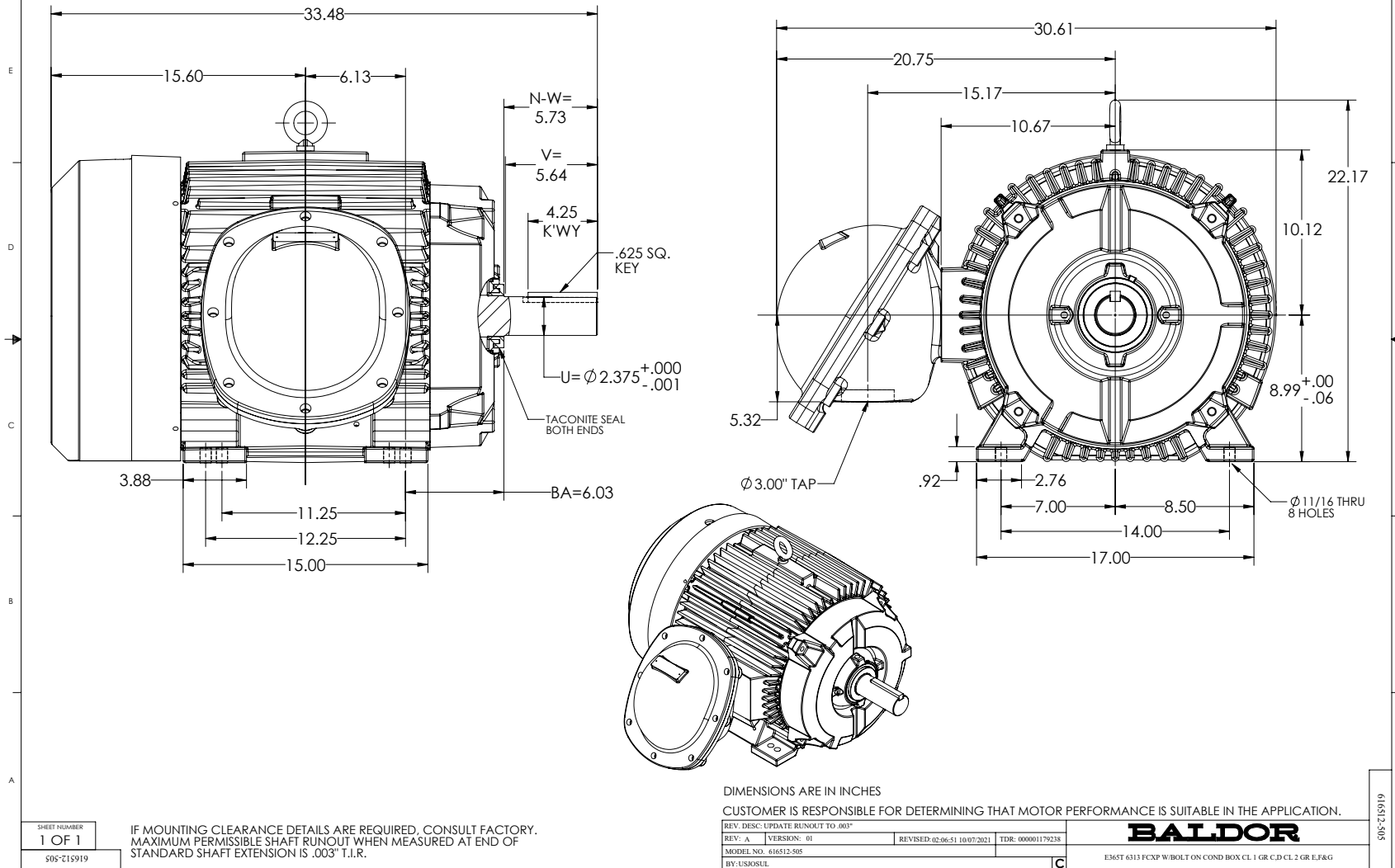

DIMENSIONS ARE IN INCHES

CUSTOMER IS RESPONSIBLE FOR DETERMINING THAT MOTOR PERFORMANCE IS SUITABLE IN THE APPLICATION.

REV. DESC: UPDATE RUNOUT TO .003"

REV: A | VERSION: 01 | REVISED: 02-06-51 10/07/2021 | TDR: 000001179238

MODEL NO. 616512-505

BY: USRSUL

BALDOR

E365T 6313 FCXP W/BOLT ON COND BOX CL 1 GR C,D CL 2 GR E,F&G

SHEET NUMBER
1 OF 1

S05-215919

IF MOUNTING CLEARANCE DETAILS ARE REQUIRED, CONSULT FACTORY.
MAXIMUM PERMISSIBLE SHAFT RUNOUT WHEN MEASURED AT END OF
STANDARD SHAFT EXTENSION IS .003" T.I.R.

616512-505

CONNECTION DIAGRAM ACCESSORIES

MOTOR WINDING THERMOSTATS	
CONTACTS _____ @ _____ °C	
FIGURE NUMBER _____	
CONTACT RATING	
VOLTS	CONTINUOUS AMPERES
110-120	3.0
220-240	1.5
440-480	0.75
550-600	0.60
	INRUSH AMPERES
	30
	15
	7.5
	6.0

NORMALLY CLOSED	THERMOSTATS	NORMALLY OPEN
FIGURE 1 		FIGURE 4
FIGURE 2 		FIGURE 5
FIGURE 3 		FIGURE 6
FIGURE 7 		FIGURE 8

CUSTOMER _____ CUSTOMER ORDER NO. _____ S.O. NO. _____

418174-006

418174-006

REV. DESC: LOADED TO BUS		
REV. LTR: A	VERSION: 01	TDR: 00000570390
FILE: \RAG\00013\849	REVISED: 10:16:21 12/07/2010	BY: RAGDRF
MTL: -		

BALDOR

A-C MOTOR CONNECTION ACCESSORIES

SH 1 of 1

416820-002

A-C MOTOR
 CONNECTION DIAGRAM
 STANDARD 9 LEAD DELTA-CONNECTED

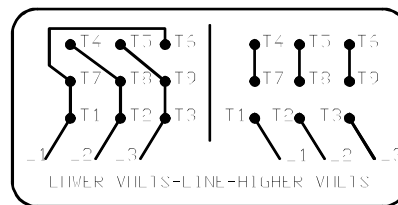
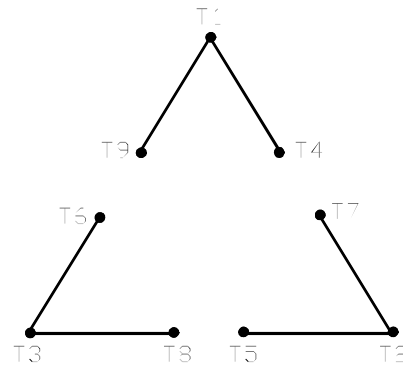

(N.P. 1575-B)

416820-002

REV. DESC: FONT CHANGE FOR PDF SEARCHABLE		
REV. LTR: A	VERSION: 01	TDR: 000001009382
FILE: \MGA\00000\661	REVISED: 02:46:19 02/13/2020	BY: MGHMTT
MTL: -	© □	

BALDOR - RELIANCE®

CONN DIAG - STANDARD 9 LEAD, DELTA-CONNECTED

SH 1 of 1