

BALDOR® • RELIANCE 

Product Information Packet

CXM18322T

3//2HP,3450//2890RPM,3PH,60//50HZ,182TC

Part Detail							
Revision:	-	Status:	PRD/A	Change #:		Proprietary:	No
Type:	AC	Elec. Spec:	36WGS041	CD Diagram:	CD0005	Mfg Plant:	
Mech. Spec:		Layout:	36LYK919	Poles:	02	Created Date:	03-16-2021
Base:		Eff. Date:	04-27-2021	Leads:	9#16		

Specs			
Catalog Number:	CXM18322T	Duty Rating:	CONT
Enclosure:	XPFC	Electrically Isolated Bearing:	Not Electrically Isolated
Frame:	182TC	Feedback Device:	NO FEEDBACK
Frame Material:	Steel	Heater Indicator:	No Heater
Output @ Frequency:	3.000 HP @ 60 HZ	Insulation Class:	F
	2.000 HP @ 50 HZ	Inverter Code:	Inverter Duty
Synchronous Speed @ Frequency:	3600 RPM @ 60 HZ	IP Rating:	NONE
Voltage @ Frequency:	190.0 V @ 50 HZ	KVA Code:	K
	460.0 V @ 60 HZ	Lifting Lugs:	No Lifting Lugs
	230.0 V @ 60 HZ	Locked Bearing Indicator:	Locked Bearing
	380.0 V @ 50 HZ	Motor Lead Termination:	Flying Leads
XP Class and Group:	CLI GP D; CLII GP F,G	Motor Type:	3622M
XP Division:	Division I	Mounting Arrangement:	F1
Agency Approvals:	UR	Power Factor:	91
	CSA EEV	Product Family:	General Purpose
	CSA	Pulley Face Code:	C-Face
Auxillary Box:	No Auxillary Box	Rodent Screen:	None
Auxillary Box Lead Termination:	None	Shaft Ground Indicator:	No Shaft Grounding

Base Indicator:	Rigid	Shaft Rotation:	Reversible
Bearing Grease Type:	Polyrex EM (-20F +300F)	Speed Code:	Single Speed
Blower:	None	Motor Standards:	NEMA
Constant Torque Speed Range:	6	Starting Method:	Direct on line
Current @ Voltage:	7.400 A @ 230.0 V	Thermal Device - Bearing:	None
	6.000 A @ 190.0 V	Thermal Device - Winding:	Normally Closed Thermostat
	3.700 A @ 460.0 V	Vibration Sensor Indicator:	No Vibration Sensor
	3.000 A @ 380.0 V	Winding Thermal 1:	None
Design Code:	A	Winding Thermal 2:	None
Drip Cover:	No Drip Cover	XP Temp Code:	T3C

Nameplate NP0887XPSLEV									
NO.					CC	010A			
S/N					TEMP CODE	T3C			
SPEC.	36-0000-0483				INV. TYPE	PWM			
CAT.NO.	CXM18322T				C HP FR	60		C HP TO	90
HP	3//2				CT HZ FROM	6		CT HZ TO	60
VOLTS	230/460//190/380				VT HZ FROM	6		VT HZ TO	60
AMPS	7.4/3.7//6/3				MAG CUR	2.4/1.2			
RPM	3450//2890				MX RPM	5400			
HZ	60//50	PH	3	CL	F	NOM.EFF.	86.5		
SER.F.	1.00		DES	A	SL HZ	2.5		WK2	0.1
FRAME	182TC		RATING	40C AMB-CONT					
	NEMA MG-1 PART 5, IP54								
	1.15 SF ON SINE WAVE								

Parts List		
Part Number	Description	Quantity
SA392971	SA 36-0000-0483	1.000 EA
RA383581	RA 36-0000-0483	1.000 EA
LB1119N	WARNING LABEL	1.000 EA
LC0145B01	CONNECTION LABEL	1.000 EA
NP0887XPSLEV	SS XP INV UL CSA-EEV CC CL-I GP-D	1.000 EA
85XU0407S04	4X1/4 U DRIVE PIN STAINLESS	2.000 EA
85XU0407S04	4X1/4 U DRIVE PIN STAINLESS	4.000 EA
MN416A01	TAG-INSTAL-MAINT no wire (2100/bx) 4/22	1.000 EA
NP0018F	ALUM UL XP CONDUIT BOX NAMEPLATE	1.000 EA
36FH4009A70	IEC FH W/(2)GREASER HOLES, W/ PRIMER	1.000 EA
51XW1032A06	10-32 X .38, TAPTITE II, HEX WSHR SLTD S	3.000 EA
34FN3002A02	EXTERNAL FAN, PLASTIC, .905/.907 HUB W/	1.000 EA
51XB0818A12	8-18X3/4 HXWSSLD SERTYB	1.000 EA
MJ1000A02	GREASE, MOBIL POLYREX EM - 124047	0.050 LB
HA3105A02	THRUBOLT 3/8-16 X 9.125 DEMBY	4.000 EA
WD4100A03	DE-750 HEYCO PLUG 62MP0750 MICRO PLASTIC	2.000 EA
36EP3700A01	FR ENDPLATE, MACH	1.000 EA
HW5100A05	WVY WSHR F/205 & 304 BRGS	1.000 EA
HW4500A19	1/4-28X1/4 SLOTTED PLUG F/S	2.000 EA
36EP1703A01	PU ENDPLATE, MACH	1.000 EA
84XN1032J20	SCREW, SOC 10-32 X 1 1/4"BMH4602	2.000 EA
HW4001A01	1/4 HX SOC PIPE PLG (F/S) ALLOY STEEL W/	2.000 EA
60XN1032A07	10-32 X .4375 TRUSS HEAD, TORX SERRATED	2.000 EA
HW3022E05	.125 DIA X .500 ROLLED SPRING PIN	1.000 EA

Parts List (continued)		
Part Number	Description	Quantity
35CB3001A02SP	EXPL PROOF CONDUIT BOX, 3/4"PIPE TAP LEA	1.000 EA
11XW1032G06	10-32 X .38, TAPTITE II, HEX WSHR SLTD U	1.000 EA
HW3001B01	BRASS CUP WASHER, FOR #10 SCREW	1.000 EA
35CB3500A01SP	CONDUIT BOX LID, MACH	1.000 EA
51XN2520A16	SCREW, HEX WS SLT, ZN, 1/4-20 X 1.00	4.000 EA
MG1500Y02	WILKOPON PRIMER YELLOW	0.022 GA
MG1025G29	WILKOFASST, 789.229, DARK CHARCOAL GRAY	0.022 GA
G0PA1000	PKG GRP, PRINT PK1026A06	1.000 EA
HW2501E19	STD SQUARE KEY .25 SQUARE X 2.125 LONG	1.000 EA
HA7000A02	KEY RETAINER RING, 1 1/8 DIA, 1 3/8 DIA	1.000 EA

AC Induction Motor Performance Data

Record # 73670

Typical performance - not guaranteed values

Winding: 36WGS041-R041		Type: 3622M		Enclosure: XPFC	
Nameplate Data			460 V, 60 Hz: High Voltage Connection		
Rated Output (HP)	3//2		Full Load Torque	4.7 LB-FT	
Volts	230/460//190/380		Start Configuration	direct on line	
Full Load Amps	7.4/3.7//6/3		Breakdown Torque	19.7 LB-FT	
R.P.M.	3450//2890		Pull-up Torque	12 LB-FT	
Hz	60//50	Phase	3	Locked-rotor Torque	14.1 LB-FT
NEMA Design Code	A	KVA Code	K	Starting Current	33.3 A
Service Factor (S.F.)	1		No-load Current	1.17 A	
NEMA Nom. Eff.	86.5	Power Factor	91	Line-line Res. @ 25°C	4.71 Ω
Rating - Duty	40C AMB-CONT		Temp. Rise @ Rated Load	52°C	
			Locked-rotor Power Factor	48.4	
			Rotor inertia	0.0984 LB-FT ²	

Load Characteristics 460 V, 60 Hz, 3 HP

% of Rated Load	25	50	75	100	125	150
Power Factor	66	82	88	91	92	93
Efficiency	80.3	86	87.3	86.9	86	84.5
Speed	3565	3535	3504	3472	3434	3394
Line amperes	1.56	2.17	2.93	3.67	4.57	5.5

Performance Graph at 460V, 60Hz, 3.0HP Typical performance - Not guaranteed values

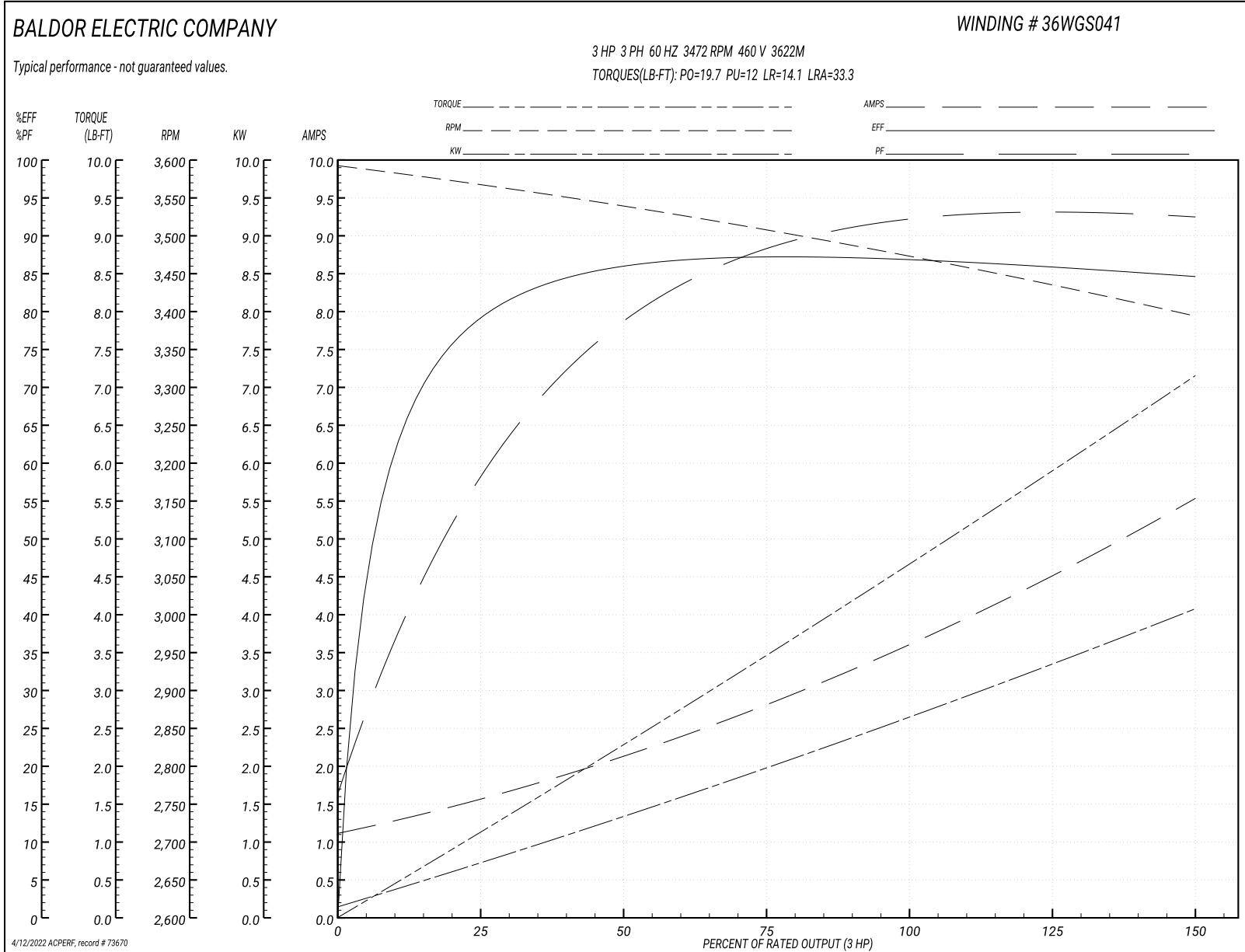

36LYK919

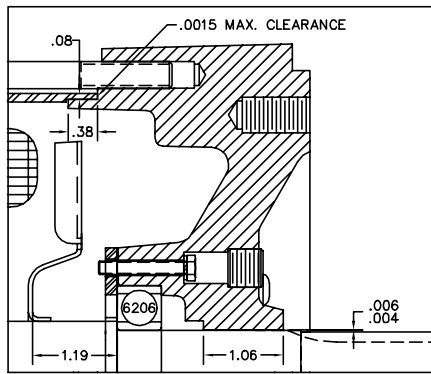
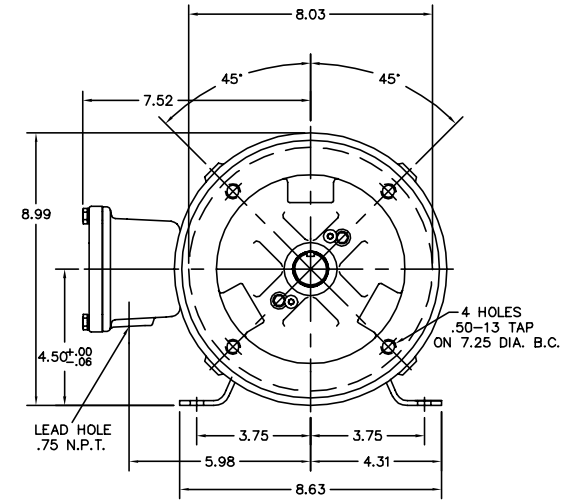
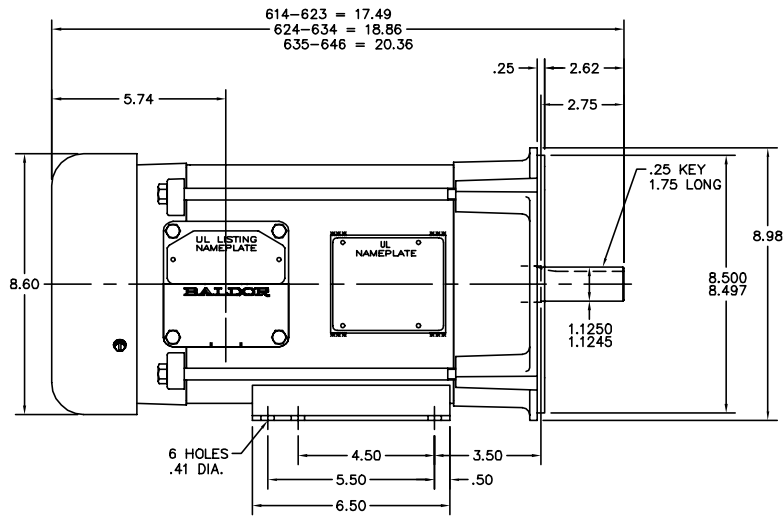

PULLEY END DETAIL

CUSTOMER IS RESPONSIBLE FOR DETERMINING THAT MOTOR PERFORMANCE IS SUITABLE IN THE APPLICATION.

REV. DESC:	NEW
REV. LTR:	- BY: RMP REVISED: 07:33:00 02/20/2004 TDR: 324828
FILE:	AAA00114068 REF: 36LYK919
MTL:	-

BALDOR ELECTRIC Co.

HORZ 182-4TC XPFC 36M DUAL CLASS, INVERTER DUTY

36LYK919

CD0005



LOW VOLTAGE
(2Y)



LINE

HIGH VOLTAGE
(1Y)

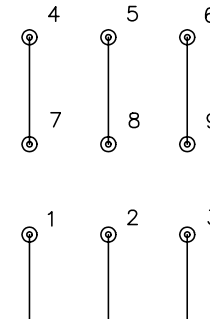

LINE

NOTES:

1. INTERCHANGE ANY TWO LINE LEADS TO REVERSE ROTATION.
2. OPTIONAL THERMOSTATS ARE PROVIDED WHEN SPECIFIED.
3. ACTUAL NUMBER OF INTERNAL PARALLEL CIRCUITS MAY BE A MULTIPLE OF THOSE SHOWN ABOVE.
4. LEAD COLORS ARE OPTIONAL. LEADS MUST ALWAYS BE NUMBERED AS SHOWN.

REV. DESC: REVISE TO SHOW OPTIONAL COLORS

REV. LTR: E BY: JLP

REVISED: 01/19/99 10:15

TDR: 0171435

90000

FILE: AAA00005140

MDL: -

MTL: -

BALDOR ELECTRIC Co.

3PH, DV, 9 LEADS

CD0005

Marketing maintained PDF of MN416:

<http://www.baldor.com/support/Literature/Load.ashx/MN416?ManNumber=MN416>