

**BALDOR® • RELIANCE** 

**Product Information Packet**

**CXM21742T**

**7.5//5HP, 1770//1470RPM, 3PH, 60//50HZ, 213T**

Part Detail							
Revision:	B	Status:	PRD/A	Change #:		Proprietary:	No
Type:	AC	Elec. Spec:	37WGR872	CD Diagram:	CD0005	Mfg Plant:	
Mech. Spec:		Layout:	37LYL772	Poles:	04	Created Date:	02-18-2021
Base:		Eff. Date:	12-09-2021	Leads:	9#14		

Specs			
Catalog Number:	CXM21742T	Duty Rating:	CONT
Enclosure:	XPFC	Electrically Isolated Bearing:	Not Electrically Isolated
Frame:	213TC	Feedback Device:	NO FEEDBACK
Frame Material:	Steel	Heater Indicator:	No Heater
Output @ Frequency:	7.500 HP @ 60 HZ	Insulation Class:	F
	5.000 HP @ 50 HZ	Inverter Code:	Inverter Duty
Synchronous Speed @ Frequency:	1800 RPM @ 60 HZ	IP Rating:	NONE
Voltage @ Frequency:	190.0 V @ 50 HZ	KVA Code:	J
	460.0 V @ 60 HZ	Lifting Lugs:	Standard Lifting Lugs
	230.0 V @ 60 HZ	Locked Bearing Indicator:	Locked Bearing
	380.0 V @ 50 HZ	Motor Lead Termination:	Flying Leads
XP Class and Group:	CLI GP D; CLII GP F,G	Motor Type:	3738M
XP Division:	Division I	Mounting Arrangement:	F1
Agency Approvals:	UR	Power Factor:	80
	CSA EEV	Product Family:	General Purpose
	CSA	Pulley Face Code:	C-Face
Auxillary Box:	No Auxillary Box	Rodent Screen:	None
Auxillary Box Lead Termination:	None	Shaft Ground Indicator:	No Shaft Grounding

<b>Base Indicator:</b>	Rigid	<b>Shaft Rotation:</b>	Reversible
<b>Bearing Grease Type:</b>	Polyrex EM (-20F +300F)	<b>Speed Code:</b>	Single Speed
<b>Blower:</b>	None	<b>Motor Standards:</b>	NEMA
<b>Constant Torque Speed Range:</b>	6	<b>Starting Method:</b>	Direct on line
<b>Current @ Voltage:</b>	9.500 A @ 460.0 V	<b>Thermal Device - Bearing:</b>	None
	8.100 A @ 380.0 V	<b>Thermal Device - Winding:</b>	Normally Closed Thermostat
	19.000 A @ 230.0 V	<b>Vibration Sensor Indicator:</b>	No Vibration Sensor
	16.200 A @ 190.0 V	<b>Winding Thermal 1:</b>	None
<b>Design Code:</b>	A	<b>Winding Thermal 2:</b>	None
<b>Drip Cover:</b>	No Drip Cover	<b>XP Temp Code:</b>	T3C

Nameplate NP0887XPSLEV										
NO.						CC	010A			
S/N						TEMP CODE	T3C			
SPEC.	37-0000-0322					INV.TYPE	PWM			
CAT.NO.	CXM21742T					C HP FR	60		C HP TO	90
HP	7.5//5					CT HZ FROM	6		CT HZ TO	60
VOLTS	230/460//190/380					VT HZ FROM	6		VT HZ TO	60
AMPS	19/9.5//16.2/8.1					MAG CUR	8.6/4.3			
RPM	1770//1470					MX RPM	2700			
HZ	60//50		PH	3		CL	F		NOM.EFF.	91.7
SER.F.	1.00		DES	A		SL HZ	1		WK2	0.934
FRAME	213TC		RATING	40C AMB-CONT						
	NEMA MG-1 PART 5, IP54									
	1.15 SF ON SINE WAVE									

Parts List		
Part Number	Description	Quantity
SA391193	SA 37-0000-0322	1.000 EA
RA381663	RA 37-0000-0322	1.000 EA
LB1115N	LABEL,LIFTING DEVICE (ON ROLLS)	1.000 EA
LB1119N	WARNING LABEL	1.000 EA
LC0145B01	CONNECTION LABEL	1.000 EA
NP0887XPSLEV	SS XP INV UL CSA-EEV CC CL-I GP-D	1.000 EA
85XU0407S04	4X1/4 U DRIVE PIN STAINLESS	2.000 EA
85XU0407S04	4X1/4 U DRIVE PIN STAINLESS	4.000 EA
MN416A01	TAG-INSTAL-MAINT no wire (2100/bx) 4/22	1.000 EA
NP0018F	ALUM UL XP CONDUIT BOX NAMEPLATE	1.000 EA
37FH4000A02SP	FAN COVER, W/ PRIMER	1.000 EA
51XW1032A06	10-32 X .38, TAPTITE II, HEX WSHR SLTD S	3.000 EA
37FN3002A01SP	EXFN, PLASTIC, 9.00 OD, 1.155 ID	1.000 EA
51XB1214A20	12-14X1.25 HXWSSLD SERTYB	1.000 EA
MJ1000A02	GREASE, MOBIL POLYREX EM - 124047	0.050 LB
HA3106A03	THRUBOLT- 1/2-13 X 11.875 X	4.000 EA
37EP1704A01	FR ENDPLATE, TEFC, CAST IRON, MACHINED	1.000 EA
HW5100A06	W2420-025 WVY WSHR (WB)	1.000 EA
HW4500A19	1/4-28X1/4 SLOTTED PLUG F/S	2.000 EA
37EP1700A01	PU EP, XPFC, 213-5TC	1.000 EA
84XN2520J26	1/4 20X1 5/8 SOC HD CP SRBLK OX	2.000 EA
HW4001A02	3/8 HX SOC PIPE PLUG W/.75" TAPER (F/S)	2.000 EA
60XN1032A07	10-32 X .4375 TRUSS HEAD, TORX SERRATED	2.000 EA
HW1001A25	LOCKWASHER 1/4, ZINC PLT .493 OD, .255 I	2.000 EA

<b>Parts List (continued)</b>		
<b>Part Number</b>	<b>Description</b>	<b>Quantity</b>
35CB3001A02SP	EXPL PROOF CONDUIT BOX, 3/4"PIPE TAP LEA	1.000 EA
11XW1032G06	10-32 X .38, TAPTITE II, HEX WSHR SLTD U	1.000 EA
HW3001B01	BRASS CUP WASHER, FOR #10 SCREW	1.000 EA
35CB3500A01SP	CONDUIT BOX LID, MACH	1.000 EA
51XN2520A16	SCREW, HEX WS SLT, ZN, 1/4-20 X 1.00	4.000 EA
MG1500Y02	WILKOPON PRIMER YELLOW	0.022 GA
MG1025G29	WILKOFASST, 789.229, DARK CHARCOAL GRAY	0.022 GA
37PA1074	PALLET PACK GRP, PRINT BOX PK1026A06	1.000 EA
HW2501F21	KEY, 5/16 SQ X 2.375	1.000 EA
HA7000A02	KEY RETAINER RING, 1 1/8 DIA, 1 3/8 DIA	1.000 EA

**AC Induction Motor Performance Data**

Record # 73680

Typical performance - not guaranteed values

<b>Winding:</b> 37WGR872-R029		<b>Type:</b> 3738M		<b>Enclosure:</b> XPFC	
<b>Nameplate Data</b>			<b>460 V, 60 Hz: High Voltage Connection</b>		
<b>Rated Output (HP)</b>	7.5//5		<b>Full Load Torque</b>	22.2 LB-FT	
<b>Volts</b>	230/460//190/380		<b>Start Configuration</b>	direct on line	
<b>Full Load Amps</b>	19/9.5//16.2/8.1		<b>Breakdown Torque</b>	70.9 LB-FT	
<b>R.P.M.</b>	1770//1470		<b>Pull-up Torque</b>	32.6 LB-FT	
<b>Hz</b>	60//50	<b>Phase</b>	3	<b>Locked-rotor Torque</b>	43 LB-FT
<b>NEMA Design Code</b>	A	<b>KVA Code</b>	J	<b>Starting Current</b>	70.9 A
<b>Service Factor (S.F.)</b>	1		<b>No-load Current</b>	4.31 A	
<b>NEMA Nom. Eff.</b>	91.7	<b>Power Factor</b>	80	<b>Line-line Res. @ 25°C</b>	1.41 Ω
<b>Rating - Duty</b>	40C AMB-CONT		<b>Temp. Rise @ Rated Load</b>	63°C	
			<b>Locked-rotor Power Factor</b>	37.2	
			<b>Rotor inertia</b>	0.934 LB-FT <sup>2</sup>	

**Load Characteristics 460 V, 60 Hz, 7.5 HP**

<b>% of Rated Load</b>	<b>25</b>	<b>50</b>	<b>75</b>	<b>100</b>	<b>125</b>	<b>150</b>
<b>Power Factor</b>	42	64	75	80	83	84
<b>Efficiency</b>	87.1	91.5	91.9	91.9	91	89.8
<b>Speed</b>	1793	1786	1778	1770	1760	1750
<b>Line amperes</b>	4.83	6.02	7.6	9.5	11.6	13.9

Performance Graph at 460V, 60Hz, 7.5HP Typical performance - Not guaranteed values

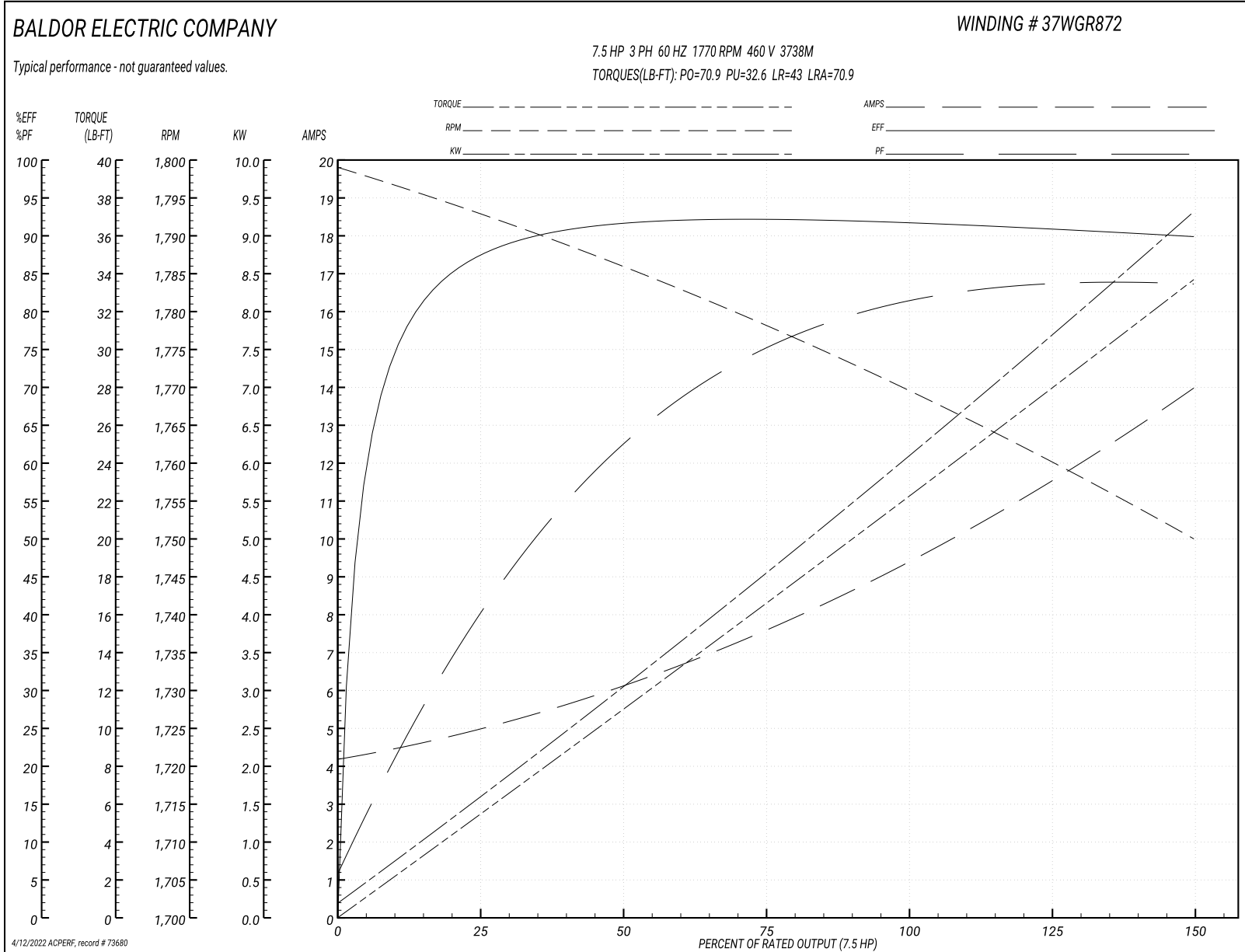



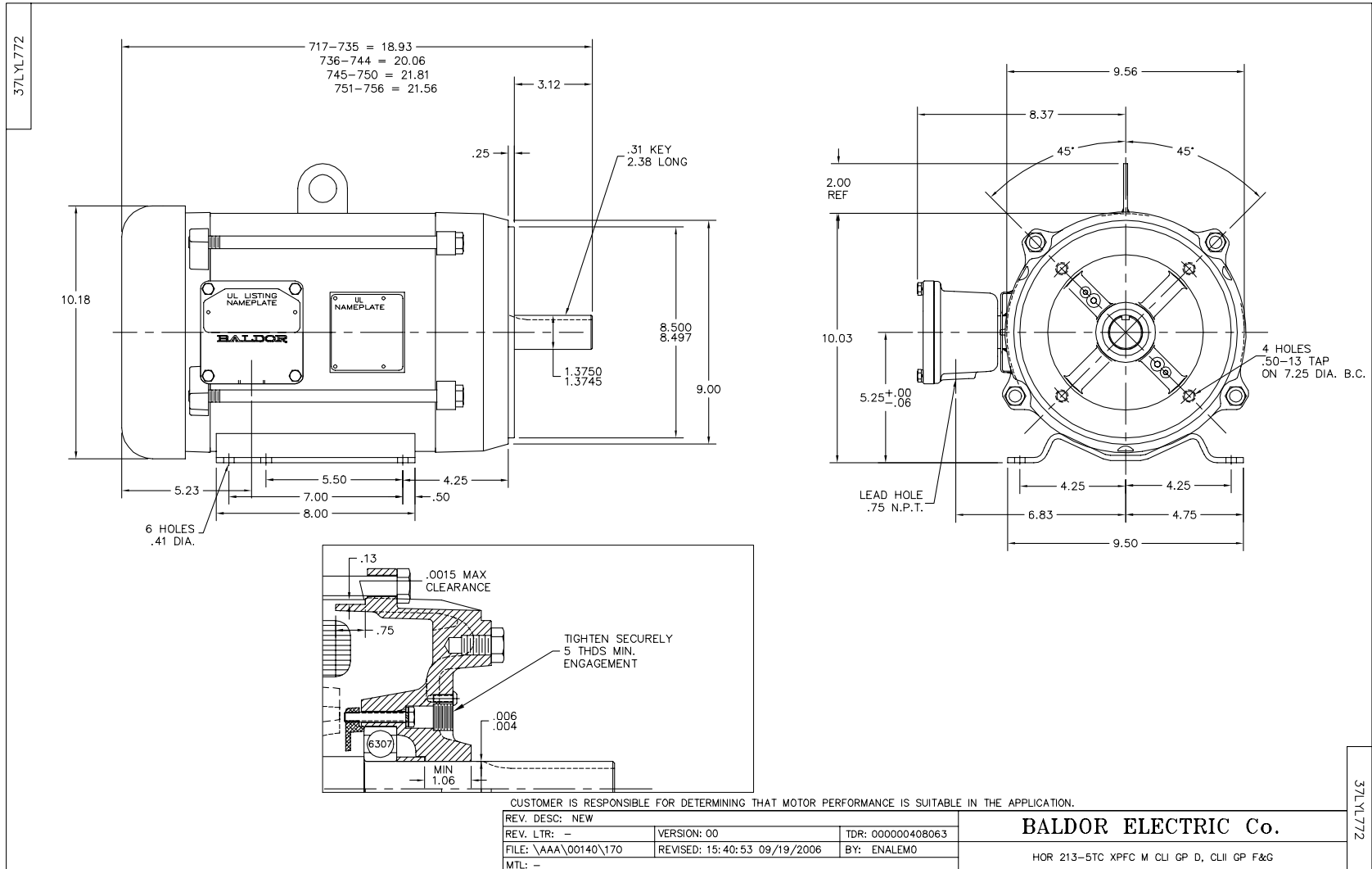

CD0005



LOW VOLTAGE  
(2Y)



LINE

HIGH VOLTAGE  
(1Y)



LINE

NOTES:

1. INTERCHANGE ANY TWO LINE LEADS TO REVERSE ROTATION.
2. OPTIONAL THERMOSTATS ARE PROVIDED WHEN SPECIFIED.
3. ACTUAL NUMBER OF INTERNAL PARALLEL CIRCUITS MAY BE A MULTIPLE OF THOSE SHOWN ABOVE.
4. LEAD COLORS ARE OPTIONAL. LEADS MUST ALWAYS BE NUMBERED AS SHOWN.

REV. DESC: REVISE TO SHOW OPTIONAL COLORS			
REV. LTR: E	BY: JLP	REVISED: 01/19/99 10:15	TDR: 0171435
90000		FILE: AAA00005140	MDL: -
		MTL: -	

**BALDOR ELECTRIC Co.**

3PH, DV, 9 LEADS

CD0005

Marketing maintained PDF of MN416:

<http://www.baldor.com/support/Literature/Load.ashx/MN416?ManNumber=MN416>