

**BALDOR® • RELIANCE** 

**Product Information Packet**

**CXT3074T**

**7.5HP, 1760RPM, 3PH, 60HZ, 213TC, 0744M, TEFC**

Part Detail							
Revision:	G	Status:	PRD/A	Change #:		Proprietary:	No
Type:	AC	Elec. Spec:	07WGT456	CD Diagram:	CD0005	Mfg Plant:	
Mech. Spec:		Layout:	07LYN006	Poles:	04	Created Date:	09-04-2020
Base:		Eff. Date:	07-14-2021	Leads:	9#14		

Specs			
Catalog Number:	CXT3074T	Electrically Isolated Bearing:	Not Electrically Isolated
Enclosure:	TEFC	Feedback Device:	NO FEEDBACK
Frame:	213TC	Heater Indicator:	No Heater
Frame Material:	Iron	Insulation Class:	F
Output @ Frequency:	7.500 HP @ 60 HZ	Inverter Code:	Inverter Duty
Synchronous Speed @ Frequency:	1800 RPM @ 60 HZ	IP Rating:	NONE
Voltage @ Frequency:	460.0 V @ 60 HZ	KVA Code:	H
	230.0 V @ 60 HZ	Lifting Lugs:	Standard Lifting Lugs
	208.0 V @ 60 HZ	Locked Bearing Indicator:	Locked Bearing
XP Class and Group:	CLI GP A,B,C,D	Motor Lead Termination:	Flying Leads
XP Division:	Division II	Motor Type:	0744M
Agency Approvals:	CCSA US	Mounting Arrangement:	F1
	CSA	Power Factor:	78
	CSA EEV	Product Family:	General Purpose
	UR	Pulley Face Code:	C-Face
Auxillary Box:	No Auxillary Box	Rodent Screen:	None
Auxillary Box Lead Termination:	None	Shaft Ground Indicator:	No Shaft Grounding
Base Indicator:	Rigid	Shaft Rotation:	Reversible

<b>Bearing Grease Type:</b>	Polyrex EM (-20F +300F)	<b>Speed Code:</b>	Single Speed
<b>Blower:</b>	None	<b>Motor Standards:</b>	NEMA
<b>Constant Torque Speed Range:</b>	3	<b>Starting Method:</b>	Direct on line
<b>Current @ Voltage:</b>	9.800 A @ 460.0 V	<b>Thermal Device - Bearing:</b>	None
	20.400 A @ 208.0 V	<b>Thermal Device - Winding:</b>	None
	19.600 A @ 230.0 V	<b>Vibration Sensor Indicator:</b>	No Vibration Sensor
<b>Design Code:</b>	B	<b>Winding Thermal 1:</b>	None
<b>Drip Cover:</b>	No Drip Cover	<b>Winding Thermal 2:</b>	None
<b>Duty Rating:</b>	CONT	<b>XP Temp Code:</b>	T3C

Nameplate NP4163L			
CAT.NO.	CXT3074T	I.P.	54
SPEC.	07-0000-0865	ENCL	TEFC
FRAME	213TC	H.P.	7.5
VOLTS	208-230/460	P.F.	78
F.L. AMPS	20.4-19.6/9.8	RATING	40C AMB-CONT
R.P.M.	1760	USABLE AT 208V	
HZ.	60	PH.	3
SER.F.	1.15	DES.	B
NEMA NOM. EFF.	91.7	W <sub>K2</sub>	1.08
DE	6307	ODE	6206
MAG. CUR.	10/5	TO	90
INV TYPE	PWM	CHP	60
CT	3	TO	60
CC	010A	VT	3
		TO	60
		T. CODE	T3C
		SN	
	USABLE AT 50 HZ 5 HP 190/380V		
	16.8/8.4A		

Parts List		
Part Number	Description	Quantity
SA385571	SA 07-0000-0865	1.000 EA
RA375823	RA 07-0000-0865	1.000 EA
LB1115N	LABEL,LIFTING DEVICE (ON ROLLS)	1.000 EA
LC0005E01	CONN.DIA./WARNING LABEL (LC0005/LB1119N)	1.000 EA
LB1449	DIV-2/NEC WARNING LABEL	1.000 EA
NP4163L	SS CP INV DIV-2 UL CSA-C US EEV PREM, DI	1.000 EA
85XU0407S04	4X1/4 U DRIVE PIN STAINLESS	2.000 EA
MN416A01	TAG-INSTAL-MAINT no wire (2100/bx) 4/22	1.000 EA
HW3201A05	3/8-16 EYEBOLT	1.000 EA
07FH4007A07	IEC FH NO GRSSR, NOTCH @ 6:00 & 3 F/C HOL	1.000 EA
51XW1032A06	10-32 X .38, TAPTITE II, HEX WSHR SLTD S	3.000 EA
37FN3002A01SP	EXFN, PLASTIC, 9.00 OD, 1.155 ID	1.000 EA
51XB1214A20	12-14X1.25 HXWSSLD SERTYB	1.000 EA
MJ1000A02	GREASE, MOBIL POLYREX EM - 124047	0.050 LB
HA3104A32	THRUBOLT- 5/16-18 X12.750	4.000 EA
XY3118A12	5/16-18 HEX NUT DIRECTIONAL SERRATION	4.000 EA
37EP3101A04	FR ENDPLATE, MACH	1.000 EA
HW4600B36SP	V-RING SLINGER 1.188 X 1.690 X .24 VITON	1.000 EA
HW5100A06	W2420-025 WVY WSHR (WB)	1.000 EA
HW4500A01	1641B(ALEMITE)400 UNIV, GREASE FITT	1.000 EA
HA4067A01	PUSH IN DRAIN FITTING (BLACK)	1.000 EA
37EP3300A05	FACE MT EP-ENCL-307 BRG-213TC-215TC LESS	1.000 EA
HW4600B33	V-RING SLINGER 1.375 X 1.890 X .35 VITON	1.000 EA
10XN2520A30	HEX HD CAP SCREW-STD THD-.25 X 20 THD PE	4.000 EA

Parts List (continued)		
Part Number	Description	Quantity
HW1001A25	LOCKWASHER 1/4, ZINC PLT .493 OD, .255 I	4.000 EA
HA4067A01	PUSH IN DRAIN FITTING (BLACK)	1.000 EA
09CB3002SP	CB W/1.38 LEAD HOLE FOR 37, 39, 307 & 30	1.000 EA
09GS1000SP	GASKET-CONDUIT BOX, 1/16 THICK LEXIDE	1.000 EA
51XW2520A12	.25-20 X .75, TAPTITE II, HEX WSHR SLTD	2.000 EA
WD1000B16	T&B CX70TN OR L70P TERMINAL LUG	1.000 EA
59XW2520G07	.25-20X.44,HEX SER WSHR,TAPTITE 2,GREEN	1.000 EA
09CB3501SP	CONDUIT BOX LID FOR 09CB3001 & 09CB3002	1.000 EA
09GS1013SP	GS FOR 09CB3501, 12CB1500 & 12CB1503 LID	1.000 EA
51XW2520A12	.25-20 X .75, TAPTITE II, HEX WSHR SLTD	2.000 EA
MG1025L14	WILKOFASST, 776.14, GRUNDFOS BLACK	0.125 GA
07PA1011	PKG GRP, 07 CAST IRON PK1181	1.000 EA
10XL3808A28	3/8 X 1 3/4" LAG SCREW	2.000 EA
HW2501F21	KEY, 5/16 SQ X 2.375	1.000 EA
HA7000A02	KEY RETAINER RING, 1 1/8 DIA, 1 3/8 DIA	1.000 EA
FE-0000001	ZRTG FE ASSEMBLY	1.000 EA
PE-0000001	ZRTG PE ASSEMBLY	1.000 EA

**AC Induction Motor Performance Data**

Record # 84568

Typical performance - not guaranteed values

<b>Winding: 07WGT456-R001</b>		<b>Type: 0744M</b>		<b>Enclosure: TEFC</b>	
<b>Nameplate Data</b>			<b>460 V, 60 Hz: High Voltage Connection</b>		
<b>Rated Output (HP)</b>	7.5	<b>Full Load Torque</b>	22.19 LB-FT		
<b>Volts</b>	208-230/460	<b>Start Configuration</b>	direct on line		
<b>Full Load Amps</b>	20.4-19.6/9.8	<b>Breakdown Torque</b>	63.85 LB-FT		
<b>R.P.M.</b>	1760	<b>Pull-up Torque</b>	46.39 LB-FT		
<b>Hz</b>	60 Phase	3	<b>Locked-rotor Torque</b>	63.42 LB-FT	
<b>NEMA Design Code</b>	B	<b>KVA Code</b>	H	<b>Starting Current</b>	65.58 A
<b>Service Factor (S.F.)</b>	1	<b>No-load Current</b>	4.78 A		
<b>NEMA Nom. Eff.</b>	91.7	<b>Power Factor</b>	78	<b>Line-line Res. @ 25°C</b>	1.12 Ω
<b>Rating - Duty</b>	40C AMB-CONT		<b>Temp. Rise @ Rated Load</b>	54°C	
			<b>Locked-rotor Power Factor</b>	37.7	
			<b>Rotor inertia</b>	1.08 lb-ft <sup>2</sup>	

**Load Characteristics 460 V, 60 Hz, 7.5 HP**

<b>% of Rated Load</b>	<b>25</b>	<b>50</b>	<b>75</b>	<b>100</b>
<b>Power Factor</b>	39	60	71	78
<b>Efficiency</b>	86.7	91.4	92	91.8
<b>Speed</b>	1793	1786	1778	1770
<b>Line amperes</b>	5.29	6.47	8.06	9.82

Performance Graph at 460V, 60Hz, 7.5HP Typical performance - Not guaranteed values

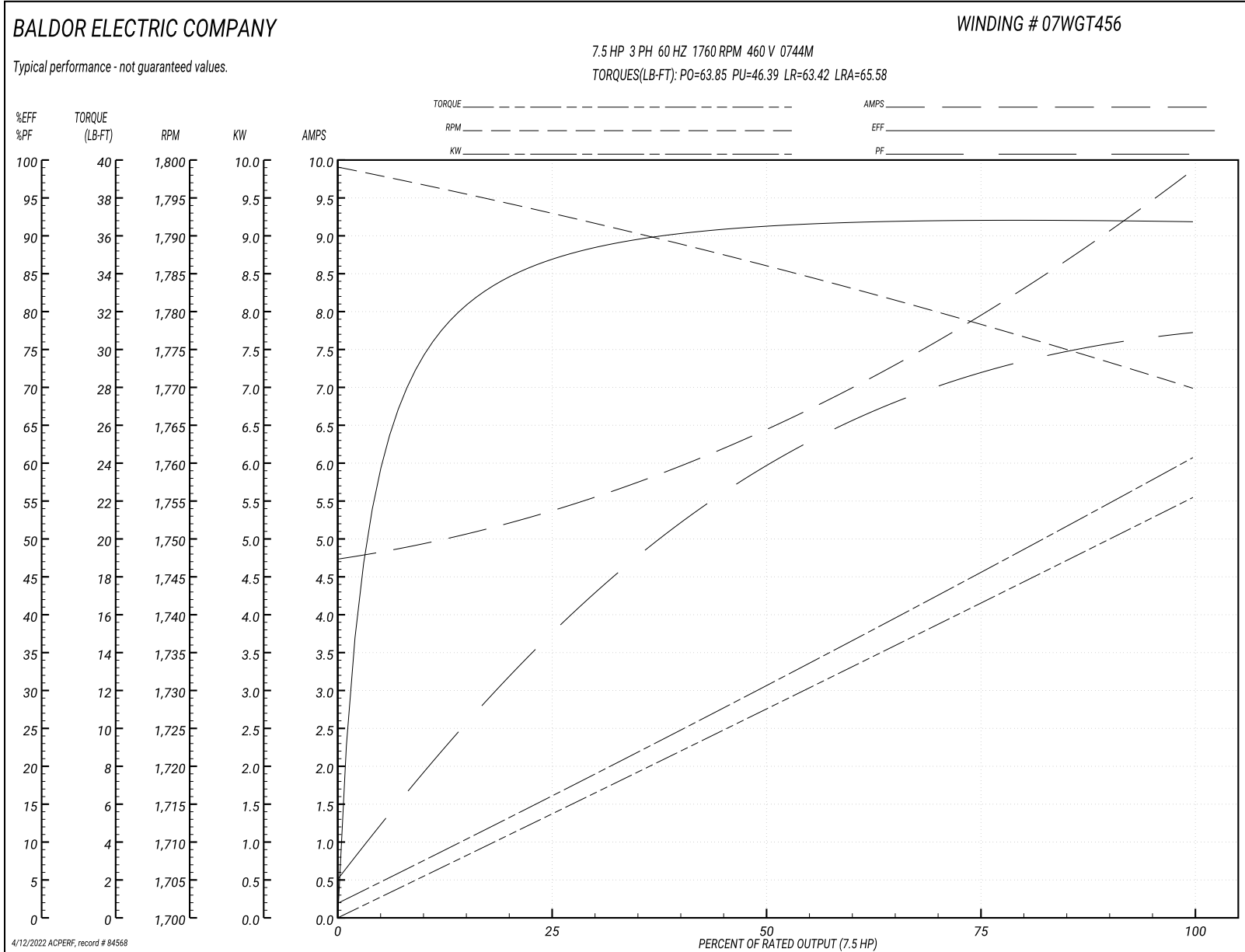



07LYN006

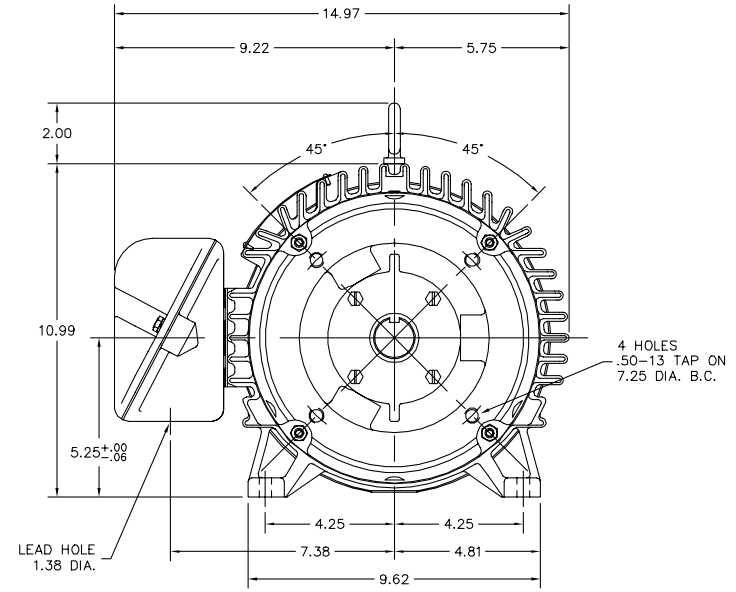
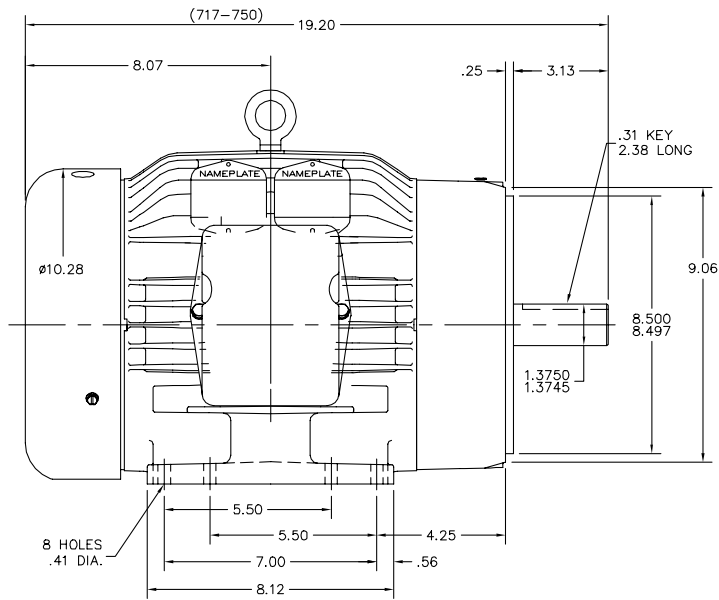

07LYN006

CUSTOMER IS RESPONSIBLE FOR DETERMINING THAT BALDOR'S PRODUCT WILL PERFORM SUITABLY IN THE INTENDED APPLICATION.

REV. DESC: REMOVE GR SR CALL OUTS		
REV. LTR: A	VERSION: 01	TDR: 000001152570
FILE: \AAA\00210\661	REVISED: 10:55:37 12/04/2020	BY: ENERIO0
MTL: -		

**BALDOR - RELIANCE**®  
 HORZ 213-5TC TEFC M SEALED BEARINGS  
 SH 1 of 1

CD0005



LOW VOLTAGE  
(2Y)



LINE

HIGH VOLTAGE  
(1Y)

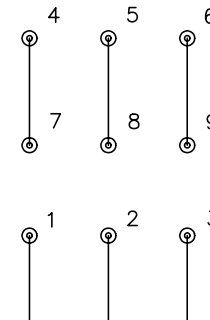

LINE

NOTES:

1. INTERCHANGE ANY TWO LINE LEADS TO REVERSE ROTATION.
2. OPTIONAL THERMOSTATS ARE PROVIDED WHEN SPECIFIED.
3. ACTUAL NUMBER OF INTERNAL PARALLEL CIRCUITS MAY BE A MULTIPLE OF THOSE SHOWN ABOVE.
4. LEAD COLORS ARE OPTIONAL. LEADS MUST ALWAYS BE NUMBERED AS SHOWN.

REV. DESC: REVISE TO SHOW OPTIONAL COLORS			
REV. LTR: E	BY: JLP	REVISED: 01/19/99 10:15	TDR: 0171435
90000		FILE: AAA00005140	MDL: -
		MTL: -	

**BALDOR ELECTRIC Co.**

3PH, DV, 9 LEADS

CD0005

Marketing maintained PDF of MN416:

<http://www.baldor.com/support/Literature/Load.ashx/MN416?ManNumber=MN416>