

BALDOR® • RELIANCE 

Product Information Packet

CXT3302TS-5

30HP,3525RPM,3PH,60HZ,286TSC,1048M,TEFC

Part Detail							
Revision:	A	Status:	PRD/A	Change #:		Proprietary:	No
Type:	AC	Elec. Spec:	10WGZ523	CD Diagram:	CD0006	Mfg Plant:	
Mech. Spec:		Layout:	10LY-001-183	Poles:	02	Created Date:	05-28-2021
Base:		Eff. Date:	07-09-2021	Leads:	3#10		

Specs			
Catalog Number:	CXT3302TS-5	Feedback Device:	NO FEEDBACK
Enclosure:	TEFC	Heater Indicator:	No Heater
Frame:	286TSC	Insulation Class:	F
Frame Material:	Iron	Inverter Code:	Inverter Duty
Output @ Frequency:	30.000 HP @ 60 HZ	IP Rating:	NONE
Synchronous Speed @ Frequency:	3600 RPM @ 60 HZ	KVA Code:	F
Voltage @ Frequency:	575.0 V @ 60 HZ	Lifting Lugs:	Standard Lifting Lugs
XP Class and Group:	CLI GP A,B,C,D	Locked Bearing Indicator:	Locked Bearing
XP Division:	Division II	Motor Lead Termination:	Flying Leads
Agency Approvals:	CSA EEV	Motor Type:	1048M
	NEMA PREMIUM	Mounting Arrangement:	F1
	NEMA_PREMIUM	Power Factor:	90
	UR	Product Family:	General Purpose
	CCSA US	Pulley Face Code:	C-Face
Auxillary Box:	No Auxillary Box	Rodent Screen:	None
Auxillary Box Lead Termination:	None	Shaft Ground Indicator:	No Shaft Grounding
Base Indicator:	Rigid	Shaft Rotation:	Reversible
Bearing Grease Type:	Polyrex EM (-20F +300F)	Speed Code:	Single Speed

Blower:	None	Motor Standards:	NEMA
Constant Torque Speed Range:	6	Starting Method:	Direct on line
Current @ Voltage:	27.000 A @ 575.0 V	Thermal Device - Bearing:	None
Design Code:	A	Thermal Device - Winding:	None
Drip Cover:	No Drip Cover	Vibration Sensor Indicator:	No Vibration Sensor
Duty Rating:	CONT	Winding Thermal 1:	None
Electrically Isolated Bearing:	Not Electrically Isolated	Winding Thermal 2:	None
		XP Temp Code:	T3

Nameplate NP4224L										
CAT.NO.	CXT3302TS-5						I.P.	54		
SPEC.	10-0000-2156						ENCL	TEFC		
FRAME	286TSC			H.P.	30			T. CODE	T3	
VOLTS	575			P.F.	90					
F.L. AMPS	27			RATING	40C AMB-CONT					
R.P.M.	3525			USABLE AT 208V						
HZ.	60			PH.	3		CLASS	F		
SER.F.	1.15			DES.	A		SL HZ	1.3		
NEMA NOM. EFF.	91.7			WV	2.07					
DE	6311			ODE	6309					
MAG. CUR.	6.8									
INV TYPE	PWM		CHP	60		TO	90		INV TEMP CODE	T3
CT	6		TO	60		VT	6		TO	60
CC	010A		SN							

Parts List		
Part Number	Description	Quantity
SA395119	SA 10-0000-2156	1.000 EA
RA385842	RA 10-0000-2156	1.000 EA
LB1115N	LABEL,LIFTING DEVICE (ON ROLLS)	1.000 EA
LB1119N	WARNING LABEL	1.000 EA
LC0006	CONNECTION LABEL	1.000 EA
LB1449	DIV-2/NEC WARNING LABEL	1.000 EA
NP4224L	SS CP INV DIV-2 UL CSA-C US EEV PREM, DI	1.000 EA
85XU0407S04	4X1/4 U DRIVE PIN STAINLESS	2.000 EA
MN416A01	TAG-INSTAL-MAINT no wire (2100/bx) 4/22	1.000 EA
10FH4000	310 FAN HOUSING STAMPED	1.000 EA
51XF2520A08	SCREW, HEX SER SLT HD, ZN 1/4-20 X .50 L	4.000 EA
37FN3002B03	EXFN, PLASTIC, 7.50 OD, 1.690 ID	1.000 EA
HW2500A25	WOODRUFF KEY USA #1008 #BLOW CARBON STEE	1.000 EA
51XB1214A20	12-14X1.25 HXWSSLD SERTYB	1.000 EA
MJ1000A02	GREASE, MOBIL POLYREX EM - 124047	0.130 LB
10EP1106A81	FREP TEFC W/"O" DRAIN W/O RET RING HLS	1.000 EA
10XN3816K32	BOLT, 3/8-16X2 HH YZ(5)	4.000 EA
HW1001A38	LOCKWASHER 3/8, ZINC PLT .688 OD, .382 I	4.000 EA
HW4600B67	V-RING SLINGER 1.770 X 2.170 X .28 VITON	1.000 EA
HW5100A11	W3917-042 WVY WSHR (WB)	1.000 EA
HA4017A11	1/8 X 2.75 GREASE EXT (F/S)	1.000 EA
HA4051A00	PLASTIC CAP FOR GREASE FITTING	1.000 EA
HW4500A21	1618BALEMITE FITTING 825 UNIVERSAL	1.000 EA
HW4500A17	317400 ALEMITE GREASE RELIEF	1.000 EA

Parts List (continued)		
Part Number	Description	Quantity
HA4066A01	PUSH IN T-DRAIN FITTING (BLACK)	1.000 EA
10EP1305A149	PU ENDPLATE, MACH	1.000 EA
HW1001A38	LOCKWASHER 3/8, ZINC PLT .688 OD, .382 I	4.000 EA
10XN3816K28	3/8-16 X 1.75 HEX HD CAP SCREW, GRADE 5	4.000 EA
HW4600B40	V-RING SLINGER 2.000 X 2.680 X .28 VITON	1.000 EA
10XN3118K40	5/16-18 X 2.50" HEX HD, GRADE 5	4.000 EA
HW1001A31	LOCKWASHER 5/16, ZINC PLT.591 OD, .319 I	4.000 EA
HA4051A00	PLASTIC CAP FOR GREASE FITTING	1.000 EA
HW4500A03	GREASE FITTING, .125 NPT 1610(ALEMITE) 8	1.000 EA
HW4500A17	317400 ALEMITE GREASE RELIEF	1.000 EA
HA4066A01	PUSH IN T-DRAIN FITTING (BLACK)	1.000 EA
10CB3000SP	KOBX, CAST W/2.00 LEAD HOLE	1.000 EA
09GS1000SP	GASKET-CONDUIT BOX, 1/16 THICK LEXIDE	1.000 EA
10XN3118K12	5/16-18 X .75 GRADE 5, ZINC PLATED	4.000 EA
HW1001A31	LOCKWASHER 5/16, ZINC PLT.591 OD, .319 I	4.000 EA
WD1000B25	GND LUG, BURNDY L125HP OR T&B L125HP-BB	1.000 EA
19XW3118G08	.31-18X.50,HEX WSHR HD,TAPTITE 2,GREEN	1.000 EA
10CB3500SP	CONDUIT BOX LID, CAST	1.000 EA
10GS1000SP	GASKET, CONDUIT BOX LID	1.000 EA
51XW2520A12	.25-20 X .75, TAPTITE II, HEX WSHR SLTD	4.000 EA
MG1025L14	WILKOFAS, 776.14, GRUNDFOS BLACK	0.125 GA
10PA1000	PACKAGING GROUP COMBINED PRINT PK1023A06	1.000 EA
HW2501G17	KEY, 3/8 SQ X 1.875	1.000 EA

AC Induction Motor Performance Data

Record # 55458

Typical performance - not guaranteed values

Winding: 10WGZ523-R001		Type: 1048M	Enclosure: TEFC
Nameplate Data		575 V, 60 Hz: Single Voltage Motor	
Rated Output (HP)	30	Full Load Torque	44.8 LB-FT
Volts	575	Start Configuration	direct on line
Full Load Amps	27	Breakdown Torque	132 LB-FT
R.P.M.	3525	Pull-up Torque	46 LB-FT
Hz	60 Phase	Locked-rotor Torque	63.8 LB-FT
NEMA Design Code	B KVA Code	Starting Current	166 A
Service Factor (S.F.)	1.15	No-load Current	6.82 A
NEMA Nom. Eff.	91.7 Power Factor	Line-line Res. @ 25°C	0.376 Ω
Rating - Duty	40C AMB-CONT	Temp. Rise @ Rated Load	69°C
S.F. Amps		Temp. Rise @ S.F. Load	86°C
		Locked-rotor Power Factor	23.2
		Rotor inertia	2.06 LB-FT ²

Load Characteristics 575 V, 60 Hz, 30 HP

% of Rated Load	25	50	75	100	125	150	S.F.
Power Factor	68	84	88	90	90	90	90
Efficiency	86.9	91.3	91.8	91.7	90.7	89.6	91.1
Speed	3583	3565	3546	3525	3503	3477	3512
Line amperes	9.8	14.9	20.9	27.3	34.5	42.1	31.6

Performance Graph at 575V, 60Hz, 30.0HP Typical performance - Not guaranteed values

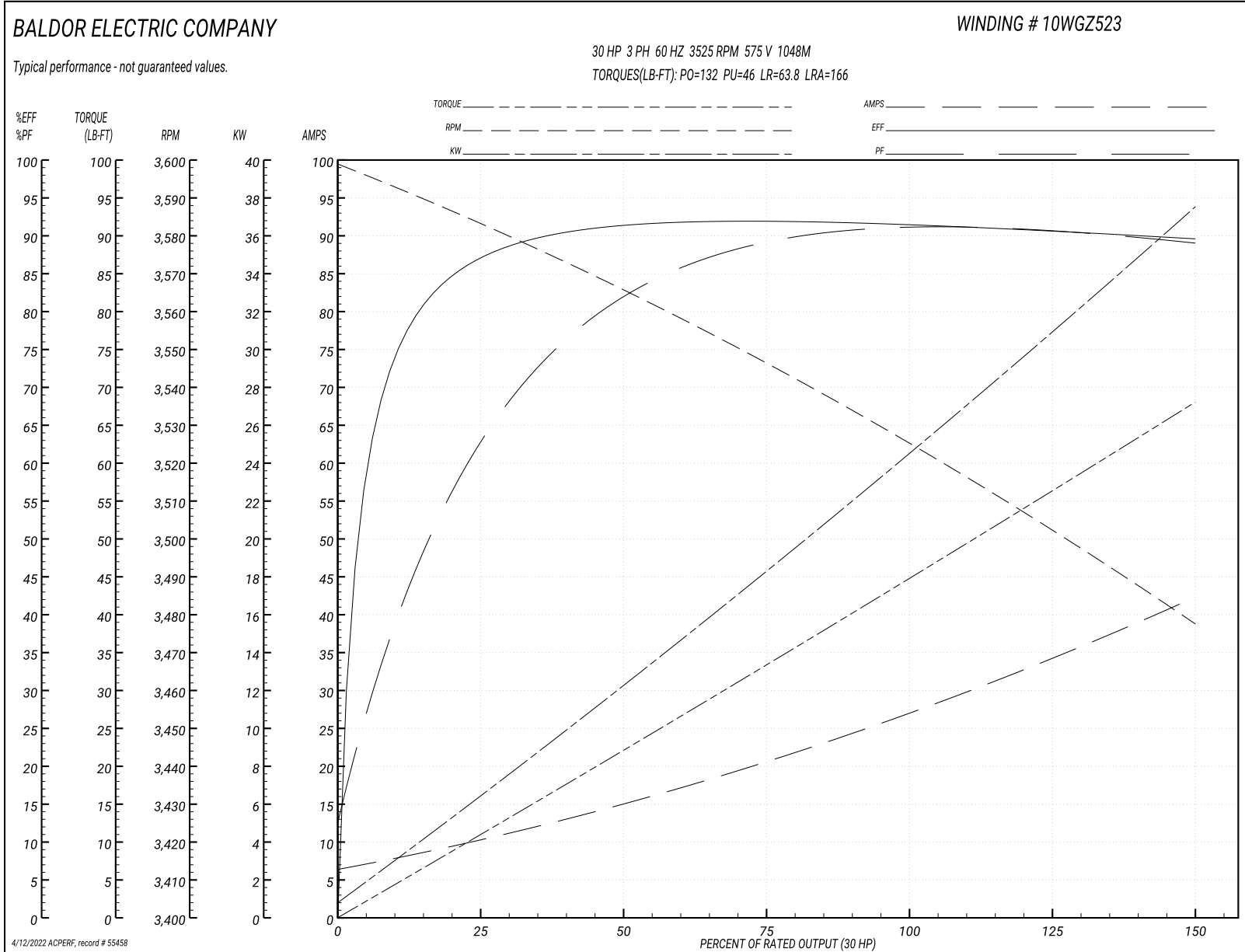

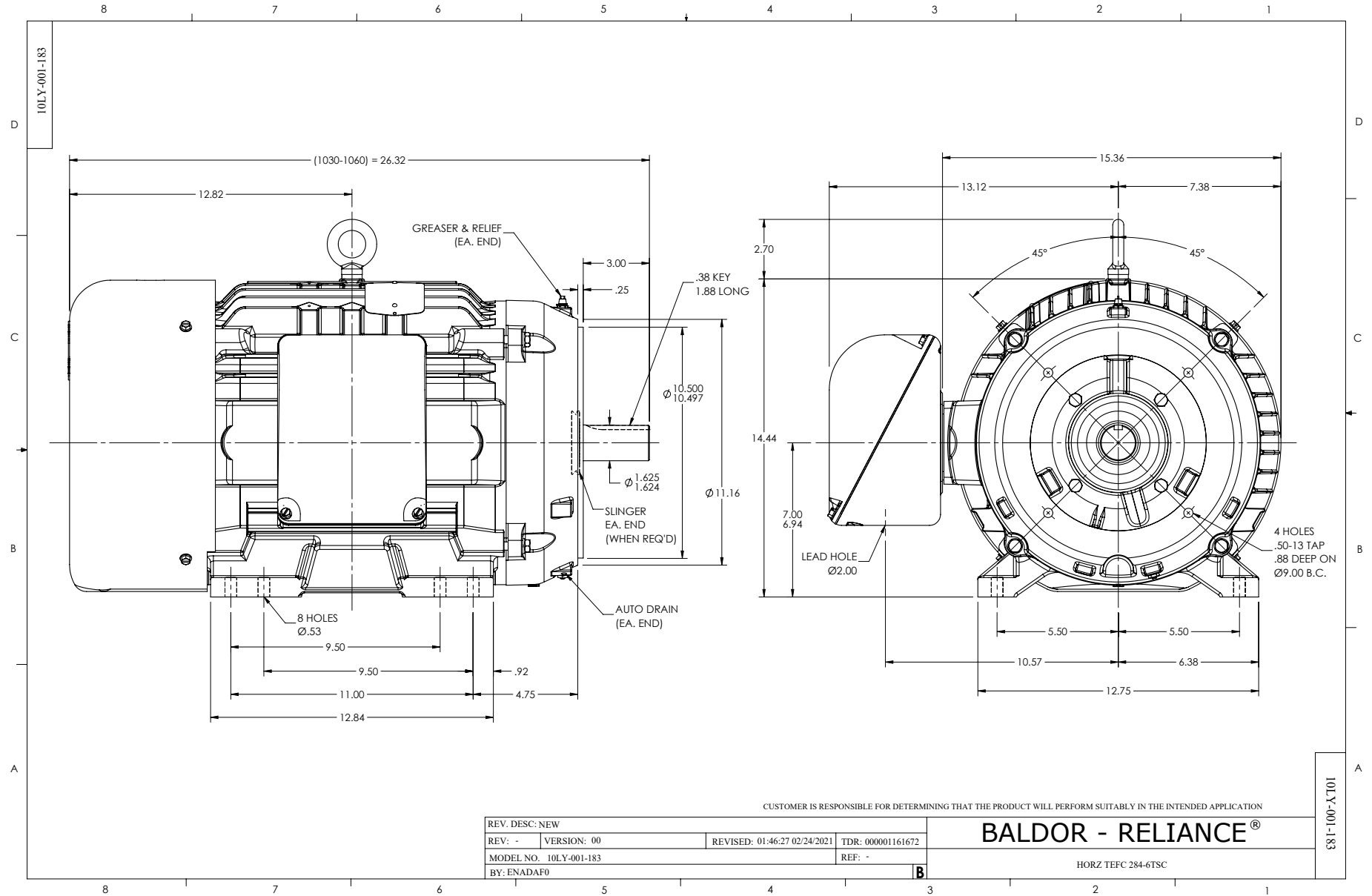

CD0006

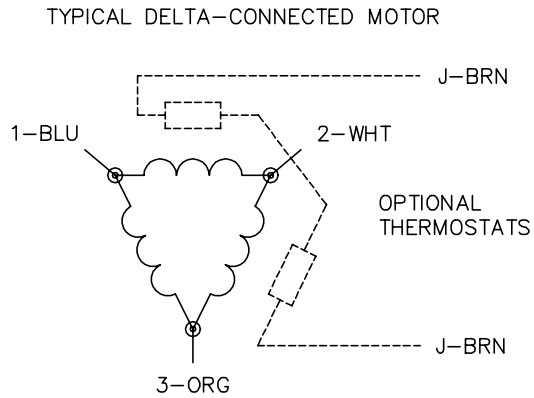
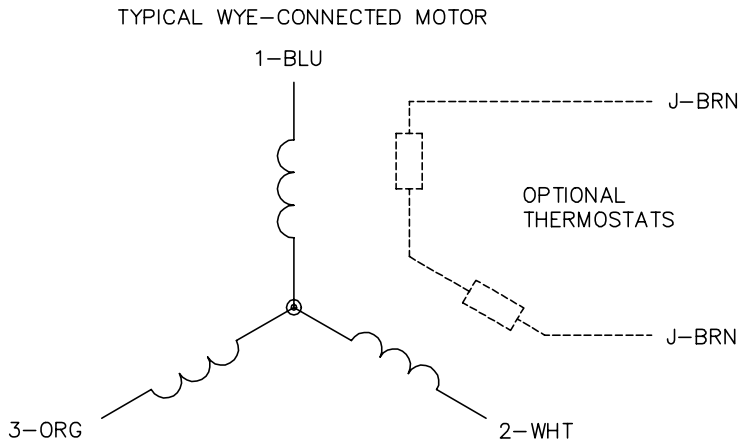

NOTES:

1. THREE LEAD MOTOR MAY BE EITHER WYE CONNECTED OR DELTA CONNECTED.
2. INTERCHANGE ANY TWO LINE LEADS TO REVERSE ROTATION.
3. OPTIONAL THERMOSTATS ARE PROVIDED WHEN SPECIFIED.
4. ACTUAL NUMBER OF INTERNAL PARALLEL CIRCUITS MAY VARY.
5. LEAD COLORS ARE OPTIONAL. LEADS MUST BE NUMBERED AS SHOWN.

CD0006

REV. DESC: ADD CLASS CONN00000007		
REV. LTR: E	VERSION: 01	TDR: 000001099922
FILE: \AAA\00005\141	REVISED: 10:24:49 02/19/2019	BY: ENBRIRO
MTL: -	© □	

BALDOR - RELIANCE®

3PH, SV, 3 LEADS, WYE OR DELTA CONNECTED

SH 1 of 1

Marketing maintained PDF of MN416:

<http://www.baldor.com/support/Literature/Load.ashx/MN416?ManNumber=MN416>