

**BALDOR® • RELIANCE** 

**Product Information Packet**

**CXT3502TS-5**

**50HP,3540RPM,3PH,60HZ,326TSC,1252M,TEFC**

Part Detail							
Revision:	-	Status:	PRD/A	Change #:		Proprietary:	No
Type:	AC	Elec. Spec:	12WGY278	CD Diagram:	CD0006	Mfg Plant:	
Mech. Spec:		Layout:	12LYF981	Poles:	02	Created Date:	06-03-2021
Base:		Eff. Date:	07-22-2021	Leads:	3#8		

Specs			
Catalog Number:	CXT3502TS-5	Feedback Device:	NO FEEDBACK
Enclosure:	TEFC	Heater Indicator:	No Heater
Frame:	326TSC	Insulation Class:	F
Frame Material:	Iron	Inverter Code:	Inverter Duty
Output @ Frequency:	50.000 HP @ 60 HZ	IP Rating:	NONE
Synchronous Speed @ Frequency:	3600 RPM @ 60 HZ	KVA Code:	H
Voltage @ Frequency:	575.0 V @ 60 HZ	Lifting Lugs:	Standard Lifting Lugs
XP Class and Group:	CLI GP A,B,C,D	Locked Bearing Indicator:	Locked Bearing
XP Division:	Division II	Motor Lead Termination:	Flying Leads
Agency Approvals:	CSA EEV	Motor Type:	1252M
	NEMA PREMIUM	Mounting Arrangement:	F1
	NEMA_PREMIUM	Power Factor:	89
	UR	Product Family:	General Purpose
	CCSA US	Pulley Face Code:	C-Face
Auxillary Box:	No Auxillary Box	Rodent Screen:	None
Auxillary Box Lead Termination:	None	Shaft Ground Indicator:	No Shaft Grounding
Base Indicator:	Rigid	Shaft Rotation:	Reversible
Bearing Grease Type:	Polyrex EM (-20F +300F)	Speed Code:	Single Speed

<b>Blower:</b>	None	<b>Motor Standards:</b>	NEMA
<b>Constant Torque Speed Range:</b>	6	<b>Starting Method:</b>	Direct on line
<b>Current @ Voltage:</b>	45.000 A @ 575.0 V	<b>Thermal Device - Bearing:</b>	None
<b>Design Code:</b>	A	<b>Thermal Device - Winding:</b>	None
<b>Drip Cover:</b>	No Drip Cover	<b>Vibration Sensor Indicator:</b>	No Vibration Sensor
<b>Duty Rating:</b>	CONT	<b>Winding Thermal 1:</b>	None
<b>Electrically Isolated Bearing:</b>	Not Electrically Isolated	<b>Winding Thermal 2:</b>	None
		<b>XP Temp Code:</b>	T3



Parts List		
Part Number	Description	Quantity
SA395575	SA 12-0000-2207	1.000 EA
RA386328	RA 12-0000-2207	1.000 EA
LB1115N	LABEL,LIFTING DEVICE (ON ROLLS)	1.000 EA
LB1119N	WARNING LABEL	1.000 EA
LC0006	CONNECTION LABEL	1.000 EA
LB1449	DIV-2/NEC WARNING LABEL	1.000 EA
NP4224L	SS CP INV DIV-2 UL CSA-C US EEV PREM, DI	1.000 EA
85XU0407S04	4X1/4 U DRIVE PIN STAINLESS	2.000 EA
MN416A01	TAG-INSTAL-MAINT no wire (2100/bx) 4/22	1.000 EA
12FH1002SP	FAN COVER, CAST	1.000 EA
HW1001A50	LOCKWASHER 1/2, ZINC PLT.,.879 OD, .509 I	4.000 EA
XY5013A12	NUT,1/2-13,HEX,STEEL,ZINCPLATED	4.000 EA
37FN3002C04	EXFN, PLASTIC, 6.00 OD, 2.003 ID	1.000 EA
HW2500A25	WOODRUFF KEY USA #1008 #BLOW CARBON STEE	1.000 EA
51XB1214A20	12-14X1.25 HXWSSLD SERTYB	1.000 EA
MJ1000A02	GREASE, MOBIL POLYREX EM - 124047	0.200 LB
12EP1107A196	FREP W/SLINGER & "0" DRAIN,W/O RET HLS	1.000 EA
HA3400A13	STUD, 1/2-13 X 7" WELKER	4.000 EA
HW1001A50	LOCKWASHER 1/2, ZINC PLT.,.879 OD, .509 I	4.000 EA
HW4600B41	V-RING SLINGER 2.125 X 2.880 X 0.280	1.000 EA
HW5100A13	W4627-047 WVY WSHER	1.000 EA
HA4017A01	1/8 X 4 GREASE EXT (F/S)	1.000 EA
HA4051A00	PLASTIC CAP FOR GREASE FITTING	1.000 EA
HW4500A21	1618BALEMITE FITTING 825 UNIVERSAL	1.000 EA

Parts List (continued)		
Part Number	Description	Quantity
HW4500A17	317400 ALEMITE GREASE RELIEF	1.000 EA
HA4066A01	PUSH IN T-DRAIN FITTING (BLACK)	1.000 EA
12EP1105A121	PU ENDPLATE, MACH W/"O" DRAIN	1.000 EA
HW1001A50	LOCKWASHER 1/2, ZINC PLT.,.879 OD, .509 I	4.000 EA
10XN5013K28	1/2-13 X 1.75 HEX HEAD MACH SCREW,GRAD	4.000 EA
HW4600B41	V-RING SLINGER 2.125 X 2.880 X 0.280	1.000 EA
10XN3118K40	5/16-18 X 2.75" HEX HD, GRADE 5	4.000 EA
HW1001A31	LOCKWASHER 5/16, ZINC PLT.591 OD, .319 I	4.000 EA
HA4051A00	PLASTIC CAP FOR GREASE FITTING	1.000 EA
HW4500A03	GREASE FITTING, .125 NPT 1610(ALEMITE) 8	1.000 EA
HW4500A17	317400 ALEMITE GREASE RELIEF	1.000 EA
HA4066A01	PUSH IN T-DRAIN FITTING (BLACK)	1.000 EA
10CB3000SP	KOBX, CAST W/2.00 LEAD HOLE	1.000 EA
09GS1000SP	GASKET-CONDUIT BOX, 1/16 THICK LEXIDE	1.000 EA
10XN3118K12	5/16-18 X .75 GRADE 5, ZINC PLATED	4.000 EA
HW1001A31	LOCKWASHER 5/16, ZINC PLT.591 OD, .319 I	4.000 EA
WD1000B25	GND LUG, BURNDY L125HP OR T&B L125HP-BB	1.000 EA
19XW3118G08	.31-18X.50,HEX WSHR HD,TAPTITE 2,GREEN	1.000 EA
10CB3500SP	CONDUIT BOX LID, CAST	1.000 EA
10GS1000SP	GASKET, CONDUIT BOX LID	1.000 EA
51XW2520A12	.25-20 X .75, TAPTITE II, HEX WSHR SLTD	4.000 EA
MG1025L14	WILKOFASST, 776.14, GRUNDFOS BLACK	0.125 GA
12PA1000	PACKAGING GROUP PRINT PK1024A07	1.000 EA
HW2501H18	KEY, 1/2 SQ X 2.000	1.000 EA

**AC Induction Motor Performance Data**

Record # 30951

Typical performance - not guaranteed values

Winding: 12WGY278-R001			Type: 1252M			Enclosure: TEFC		
<b>Nameplate Data</b>				<b>575 V, 60 Hz: Single Voltage Motor</b>				
Rated Output (HP)	50		Full Load Torque	74.2 LB-FT				
Volts	575		Start Configuration	direct on line				
Full Load Amps	45		Breakdown Torque	292 LB-FT				
R.P.M.	3540		Pull-up Torque	98.7 LB-FT				
Hz	60 Phase	3	Locked-rotor Torque	135 LB-FT				
NEMA Design Code	A KVA Code	H	Starting Current	325 A				
Service Factor (S.F.)	1.15		No-load Current	13.9 A				
NEMA Nom. Eff.	93 Power Factor	89	Line-line Res. @ 25°C	0.174 Ω				
Rating - Duty	40C AMB-CONT		Temp. Rise @ Rated Load	80°C				
S.F. Amps			Temp. Rise @ S.F. Load	98°C				
			Locked-rotor Power Factor	21				
			Rotor inertia	4.07 LB-FT <sup>2</sup>				

**Load Characteristics 575 V, 60 Hz, 50 HP**

% of Rated Load	25	50	75	100	125	150	S.F.
Power Factor	58	79	86	89	90	90	90
Efficiency	90.6	93.6	94.3	94.1	93.3	92.7	93.6
Speed	3585	3573	3561	3550	3538	3526	3543
Line amperes	17.7	25.4	34.6	44.8	55.7	66.6	51.3

Performance Graph at 575V, 60Hz, 50.0HP Typical performance - Not guaranteed values

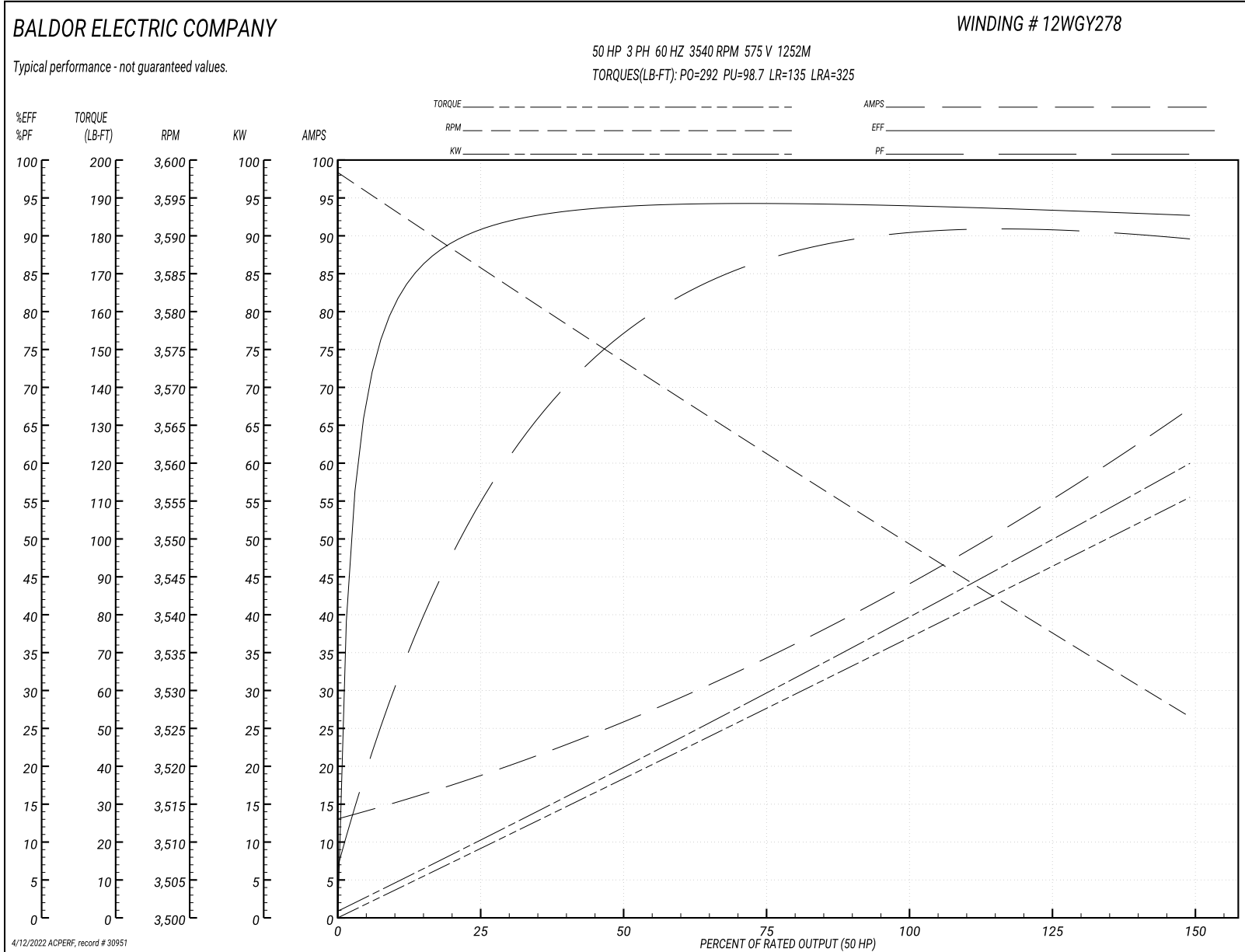



12LYF981

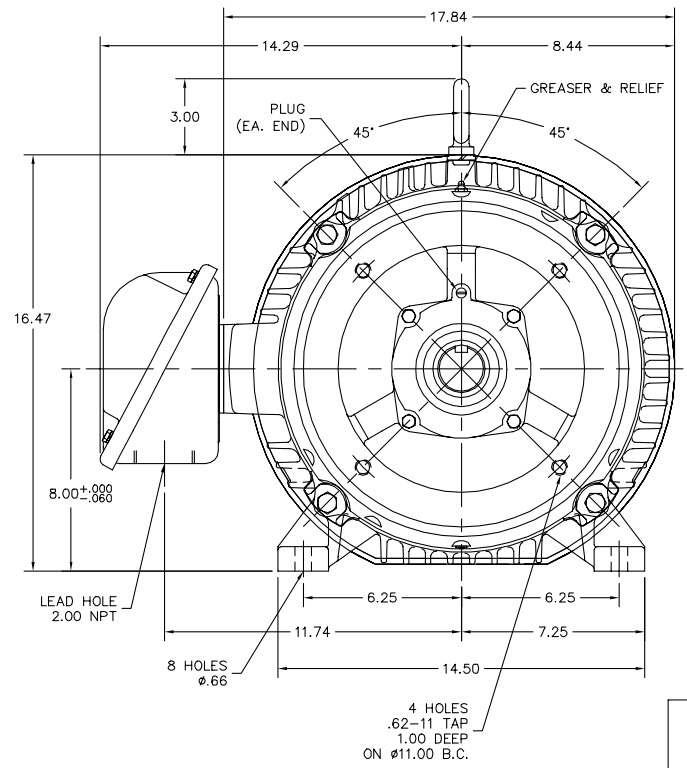
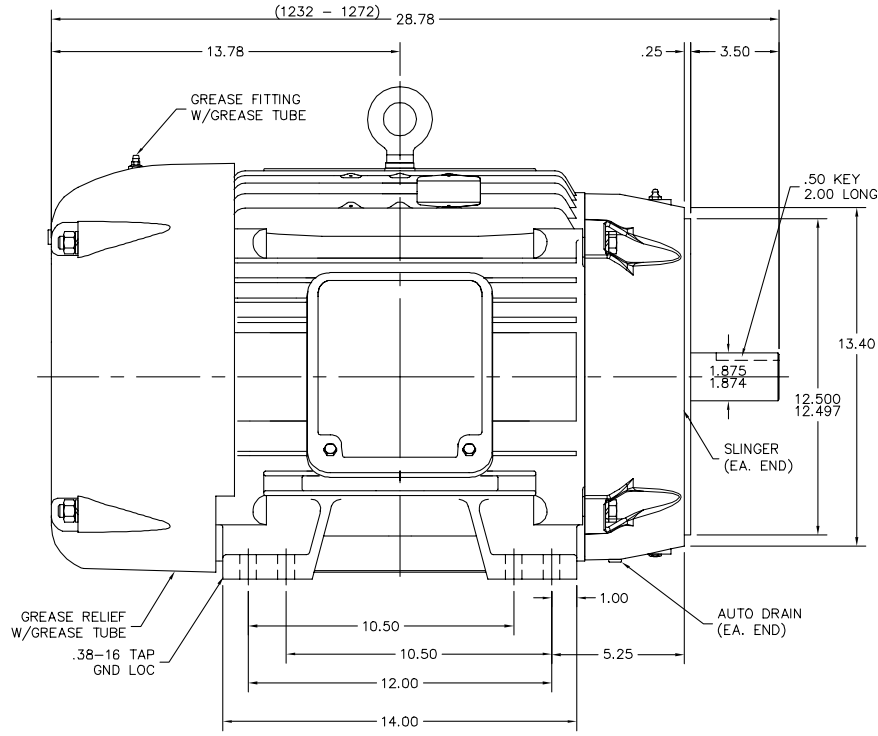

12LYF981

CUSTOMER IS RESPONSIBLE FOR DETERMINING THAT BALDOR'S PRODUCT WILL PERFORM SUITABLY IN THE INTENDED APPLICATION.

REV. DESC: ADDED GND HOLE TAP SIZE	VERSION: 05	TDR: 000000954909
REV. LTR: E	REVISED: 12:29:32 12/07/2015	BY: ENNINDO
FILE: \AAA\00178\621		
MTL: -		

**BALDOR**  
 HORZ TEFC 324-6TSC ECP W/312 BRGS, PLS  
 SH 1 of 1

CD0006



NOTES:

1. THREE LEAD MOTOR MAY BE EITHER WYE CONNECTED OR DELTA CONNECTED.
2. INTERCHANGE ANY TWO LINE LEADS TO REVERSE ROTATION.
3. OPTIONAL THERMOSTATS ARE PROVIDED WHEN SPECIFIED.
4. ACTUAL NUMBER OF INTERNAL PARALLEL CIRCUITS MAY VARY.
5. LEAD COLORS ARE OPTIONAL. LEADS MUST BE NUMBERED AS SHOWN.

CD0006

REV. DESC: ADD CLASS CONN00000007		
REV. LTR: E	VERSION: 01	TDR: 000001099922
FILE: \AAA\00005\141	REVISED: 10:24:49 02/19/2019	BY: ENBRIRO
MTL: -		

**BALDOR - RELIANCE®**

3PH, SV, 3 LEADS, WYE OR DELTA CONNECTED

SH 1 of 1

Marketing maintained PDF of MN416:

<http://www.baldor.com/support/Literature/Load.ashx/MN416?ManNumber=MN416>