

DATE
February 20, 2007
CATALOG NO.
DHP1/545

OUTLINE DIMENSIONS
3-PHASE INDUCTION MOTOR

MOTOR TYPE:
ASHH
FRAME NO. 145T

Pole	HP	KW	Hz	VOLT	Syn. Speed RPM
4	1.5	1	60	575	1800

Ins	Rating	Dimension in	Approx Weight	Bearings
F	CONT.	inch	66 lbs.	DE: 6205ZZ NDE: 6205ZZ

Open Protected Drip-Proof Squirrel Cage Rotor.

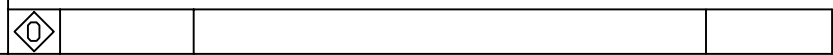
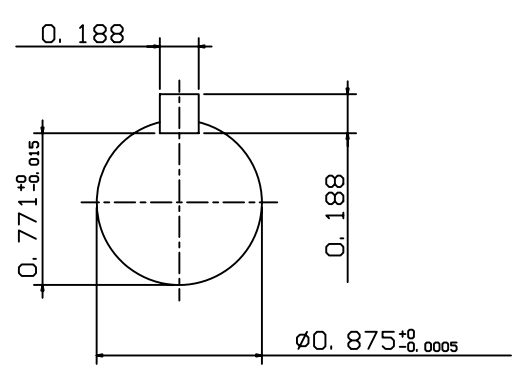
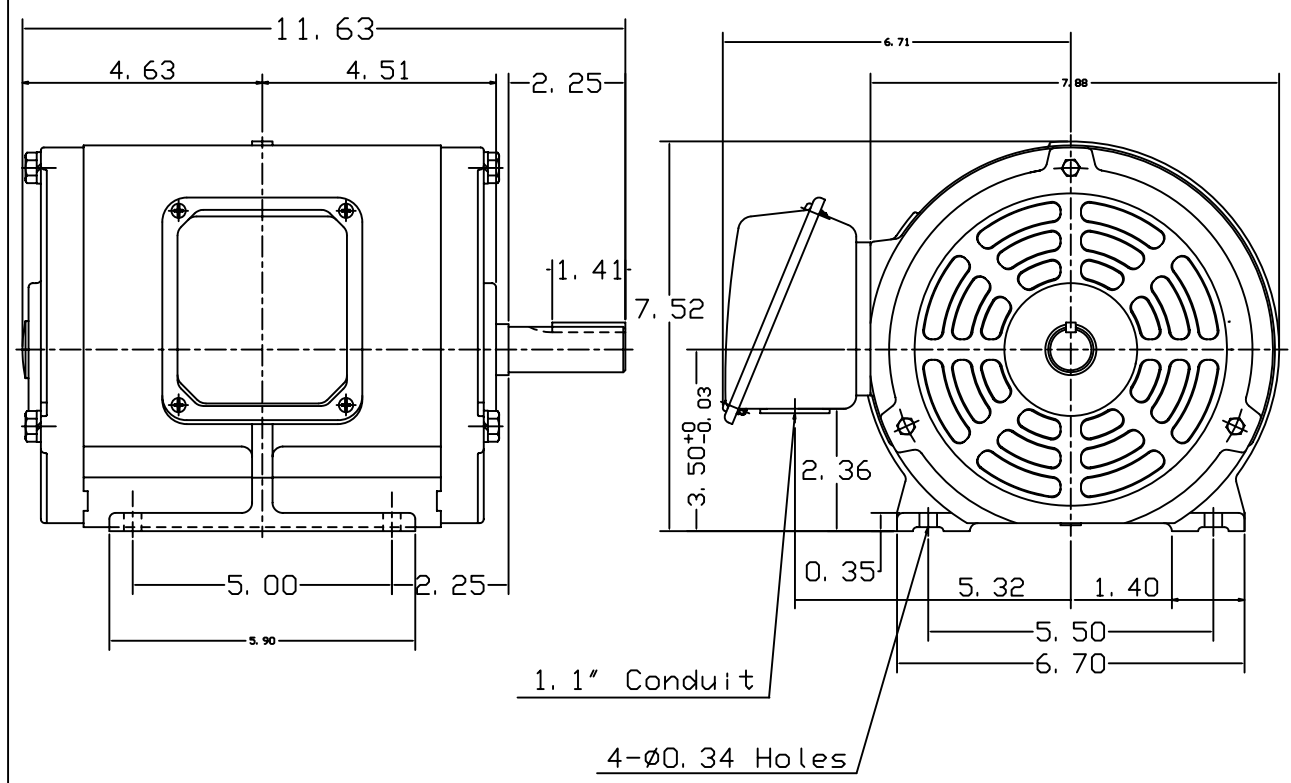

DWN.	J. H. LIANG	12-22-98
CHKD.	C. S. LO	05-20-99
APPD.	Y. B. HUANG	05-20-99



DWG NO.
31057H378001

TECO Westinghouse

ISSUED June 7, 2007	PERFORMANCE DATA	ENCLOSURE ODP
TYPE ASHH	3-PHASE INDUCTION MOTOR	CATALOG# DHP1/545

NAMEPLATE INFORMATION

OUTPUT		POLE	FRAME SIZE	VOLTAGE	HZ	RATED AMBIENT	INS. CLASS	NEMA DESIGN	TIME RATING	SERVICE FACTOR
HP	KW									
1.5	1.1	4	145T	575	60	40°C	F	B	CONT.	1.15

TYPICAL PERFORMANCE

FULL LOAD RPM	EFFICIENCY				POWER FACTOR			MAXIMUM POWER FACTOR CORRECTION
	FULL LOAD		3/4 LOAD %	1/2 LOAD %	F. L. %	3/4 LOAD %	1/2 LOAD %	
	MIN. %	NOM. %						
1740	84.0	86.5	86.5	86.5	80.5	73.0	60.0	0.9 KVAR

CURRENTS

NO LOAD		FULL LOAD			LOCKED ROTOR			NEMA KVA CODE LETTER
AT 575 VOLT		AT 575 VOLT			AT 575 VOLT			
0.84		1.61		16.00			M	

TORQUE

INERTIA

ACCEL TIME

FULL LOAD lb-ft	LOCKED ROTOR %FLT	PULL UP %FLT	BREAK DOWN %FLT	ROTOR WR ² lb-ft ²	NEMA LOAD WK ² lb-ft ²	MAX ALLOWABLE WK ² lb-ft ²	NEMA LOAD WK ² Sec	MAX ALLOWABLE WK ² Sec
4.526	250	190	310	0.093	8.6	38	4.26	18.65

SAFE STALL TIME IN SECONDS

ALLOWABLE STARTS PER HOUR

SOUND PRESSURE LEVEL @ 3 FT dB(A)

COLD	HOT	COLD	HOT	45
31	22	2	1	

APPROVED:	M. PRATER	DRAWING NO.	31057DHP1/545	REVISION 0
-----------	------------------	-------------	----------------------	-------------------

DATE:

October 18, 2007

CONNECTION DIAGRAM

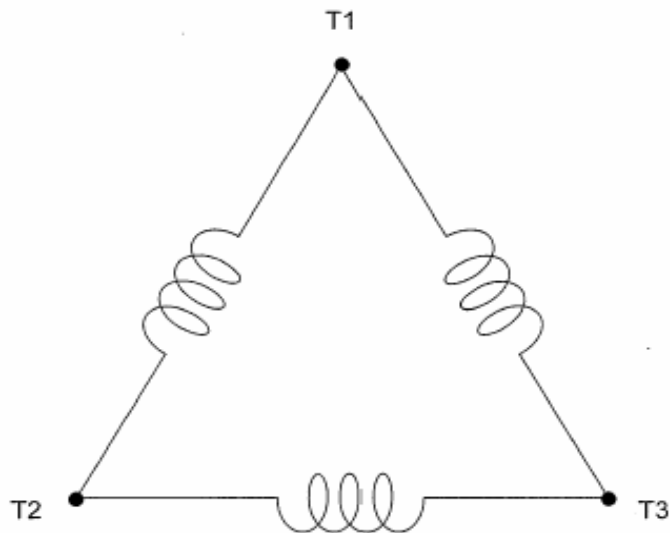

SCHEMATIC - Δ CONNECTION

ACROSS THE LINE CONNECTION



575 VOLT CONNECTION