

DATE  
February 20, 2007  
CATALOG NO.  
DHP1/54G

OUTLINE DIMENSIONS  
3-PHASE INDUCTION MOTOR

MOTOR TYPE:  
ASHH  
FRAME NO. 145T

Pole	HP	KW	Hz	VOLT	Syn. Speed RPM
4	1.5	1	60	230/460	1800

Ins	Rating	Dimension in	Approx Weight	Bearings
F	CONT.	inch	66 lbs.	DE: 6205ZZ NDE: 6205ZZ

Open Protected Drip-Proof Squirrel Cage Rotor.

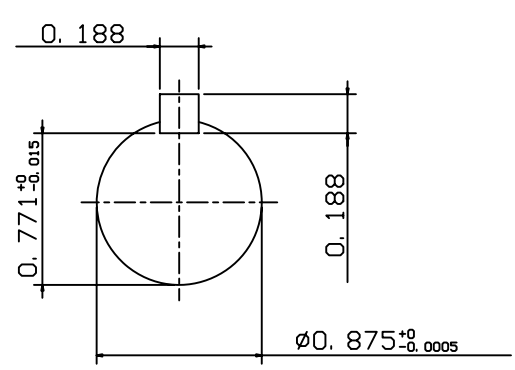
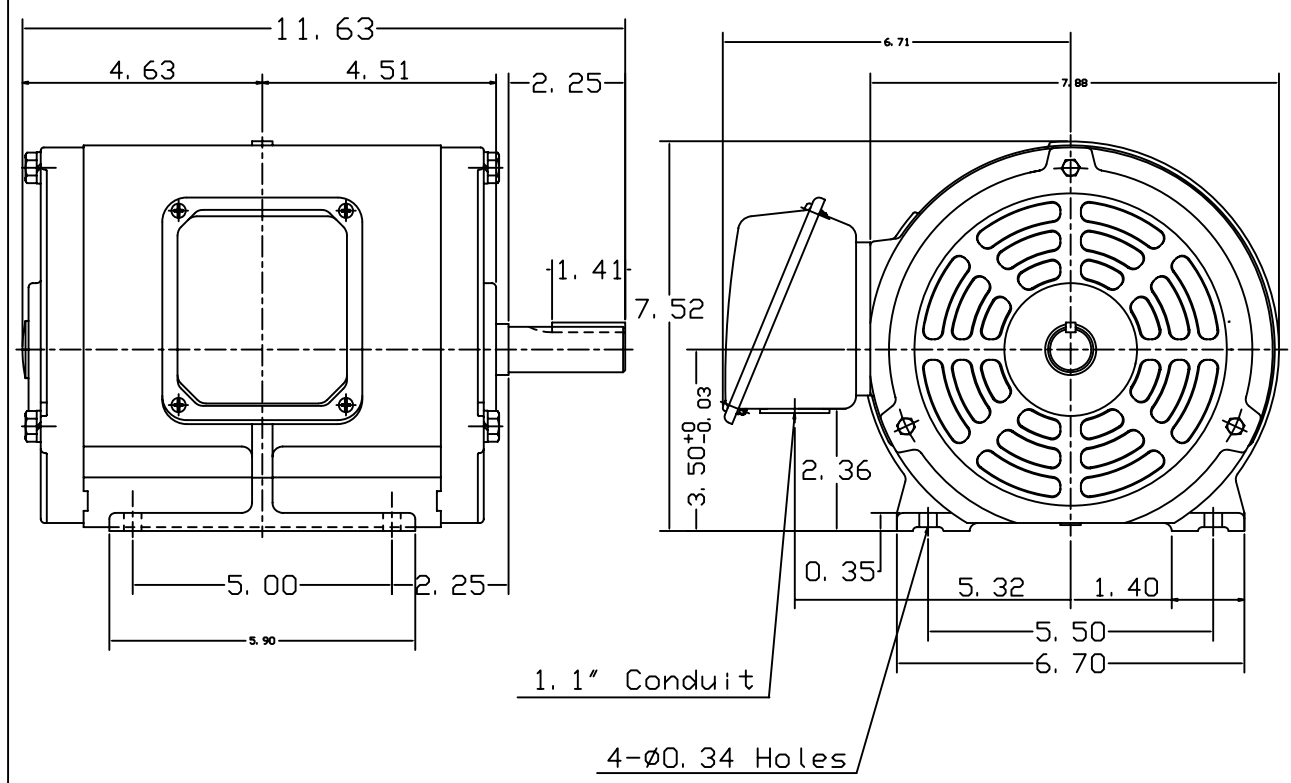

NOTES:  
1. SHAFT GROUNDING RING  
INSTALLED.

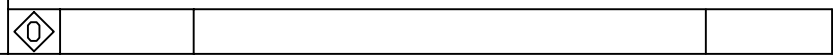

DWN.	J. H. LIANG	12-22-98
CHKD.	C. S. LO	05-20-99
APPD.	Y. B. HUANG	05-20-99



DWG NO.  
31057H378001

# TECO Westinghouse

ISSUED <b>May 3, 2007</b>	<b>PERFORMANCE DATA</b>	ENCLOSURE <b>ODP</b>
TYPE <b>ASHH</b>	<b>3-PHASE INDUCTION MOTOR</b>	CATALOG# <b>DHP1/54G</b>

### NAMEPLATE INFORMATION

OUTPUT		POLE	FRAME SIZE	VOLTAGE	HZ	RATED AMBIENT	INS. CLASS	NEMA DESIGN	TIME RATING	SERVICE FACTOR
HP	KW									
<b>1.5</b>	<b>1.1</b>	<b>4</b>	<b>145T</b>	<b>230/460</b>	<b>60</b>	<b>40°C</b>	<b>F</b>	<b>B</b>	<b>CONT.</b>	<b>1.15</b>

### TYPICAL PERFORMANCE

FULL LOAD RPM	EFFICIENCY				POWER FACTOR			MAXIMUM POWER FACTOR CORRECTION
	FULL LOAD		3/4 LOAD	1/2 LOAD	F. L.	3/4 LOAD	1/2 LOAD	
	MIN. %	NOM. %	%	%	%	%	%	
<b>1740</b>	<b>84</b>	<b>86.5</b>	<b>86.5</b>	<b>86.5</b>	<b>80.5</b>	<b>73</b>	<b>60</b>	<b>0.8 KVAR</b>

### CURRENTS

NO LOAD			FULL LOAD			LOCKED ROTOR			NEMA KVA CODE LETTER
AT	AT	AT	AT	AT	AT	AT	AT	AT	
208 VOLT	230 VOLT	460 VOLT	208 VOLT	230 VOLT	460 VOLT	208 VOLT	230 VOLT	460 VOLT	
<b>2.34</b>	<b>2.11</b>	<b>1.06</b>	<b>4.42</b>	<b>4.03</b>	<b>2.00</b>	<b>44.23</b>	<b>40.00</b>	<b>20.00</b>	<b>M</b>

### TORQUE

### INERTIA

### ACCEL TIME

FULL LOAD lb-ft	LOCKED ROTOR %FLT	PULL UP %FLT	BREAK DOWN %FLT	ROTOR WR <sup>2</sup> lb-ft <sup>2</sup>	NEMA LOAD WK <sup>2</sup> lb-ft <sup>2</sup>	MAX ALLOWABLE WK <sup>2</sup> lb-ft <sup>2</sup>	NEMA LOAD WK <sup>2</sup> Sec	MAX ALLOWABLE WK <sup>2</sup> Sec
<b>4.526</b>	<b>250</b>	<b>190</b>	<b>310</b>	<b>0.093</b>	<b>8.6</b>	<b>38</b>	<b>4.26</b>	<b>18.65</b>

SAFE STALL TIME IN SECONDS

ALLOWABLE STARTS PER HOUR

SOUND PRESSURE LEVEL @ 3 FT dB(A)

COLD	HOT	COLD	HOT	45
<b>31</b>	<b>22</b>	<b>2</b>	<b>1</b>	

APPROVED:	<b>M. PRATER</b>	DRAWING NO.	<b>31057DHP1/54G</b>	REVISION <b>0</b>
-----------	------------------	-------------	----------------------	-------------------

DATE:  
February 16, 2007

# CONNECTION DIAGRAM



**SCHEMATIC - 2Y/Y CONNECTION**

## ACROSS THE LINE CONNECTION

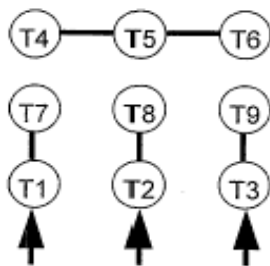

**LINE  
230 VOLT CONNECTION**

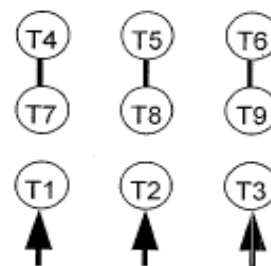

**LINE  
460 VOLT CONNECTION**