

TYPE	OUTPUT		POLE	TIME RATING CNT.	VOLTAGE V	Hz	SYN SPEED R.P.M
	HP.	KW.					
ASHH	125	93.3	6		575	60	1200

DRIP PROOF TYPE, SQUIRREL-CAGE ROTOR

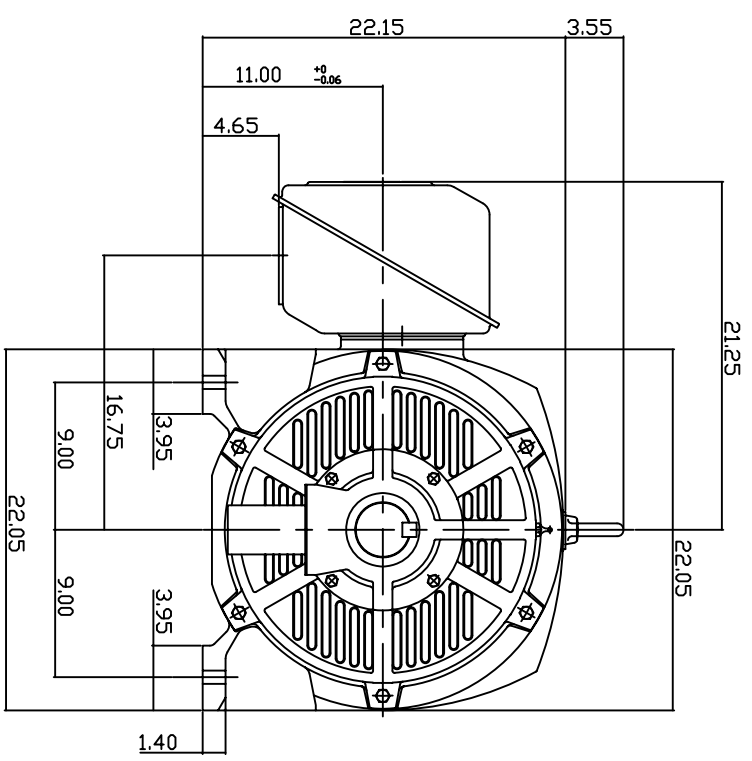
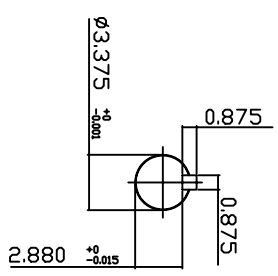
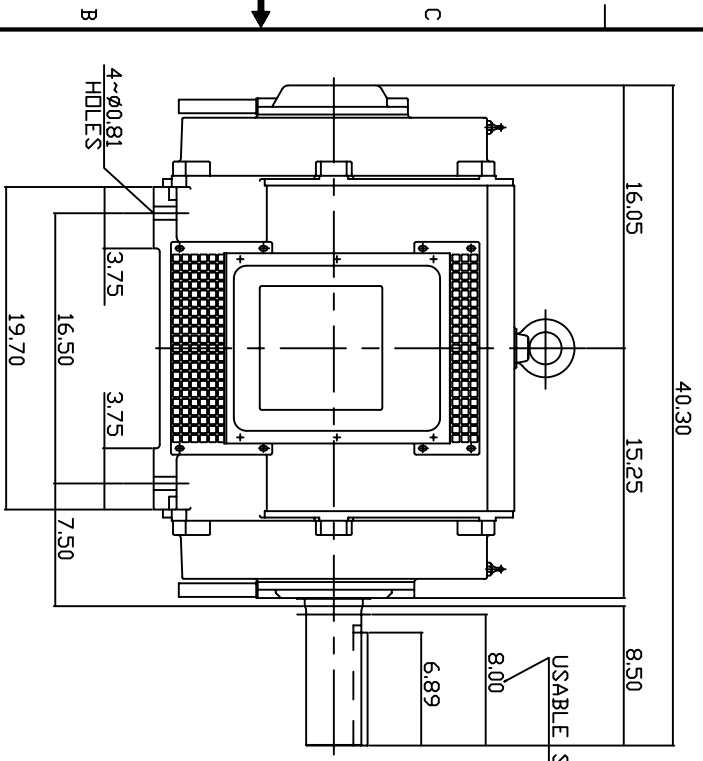

NOTE:

1. DIMENSIONS IN INCH.
2. FRAME ND445T
3. F CLASS INSULATION, S.F.115
4. FOR DIRECT DRIVE
5. BEARING SIZE: DRIVE END: 6318
NON-DRIVE END: 6316
6. MOTOR APPROX. WEIGHT: 1430LBS

TB-56SSC

DWN.	V.L.LIN	MAR-26-2003
CHKD.	W.L.LIN	MAR-26-2003
APPD.	C.VANG	MAR-26-2003

DATE May 25, 2007
 Cat # DHP12565
 OUTLINE DIMENSIONS
 3-PHASE INDUCTION MOTOR



DWG NO. 3A040T261
 REV: 00

TECO Westinghouse

ISSUED June 7, 2007	PERFORMANCE DATA	ENCLOSURE ODP
TYPE ASHH	3-PHASE INDUCTION MOTOR	CATALOG# DHP12565

NAMEPLATE INFORMATION

OUTPUT		POLE	FRAME SIZE	VOLTAGE	HZ	RATED AMBIENT	INS. CLASS	NEMA DESIGN	TIME RATING	SERVICE FACTOR
HP	KW									
125	93.3	6	445T	575	60	40°C	F	B	CONT.	1.15

TYPICAL PERFORMANCE

FULL LOAD RPM	EFFICIENCY				POWER FACTOR			MAXIMUM POWER FACTOR CORRECTION
	FULL LOAD		3/4 LOAD %	1/2 LOAD %	F. L. %	3/4 LOAD %	1/2 LOAD %	
	MIN. %	NOM. %						
1181	94.1	95.0	94.5	93.3	82.0	79.2	75.4	33.8 KVAR

CURRENTS

NO LOAD		FULL LOAD			LOCKED ROTOR			NEMA KVA CODE LETTER
AT 575 VOLT		AT 575 VOLT			AT 575 VOLT			
47.80			120.00			726.00	G	

TORQUE

INERTIA

ACCEL TIME

FULL LOAD lb-ft	LOCKED ROTOR %FLT	PULL UP %FLT	BREAK DOWN %FLT	ROTOR WR ² lb-ft ²	NEMA LOAD WK ² lb-ft ²	MAX ALLOWABLE WK ² lb-ft ²	NEMA LOAD WK ² Sec	MAX ALLOWABLE WK ² Sec
556	140	120	210	51	1452	3630	6.16	15.08

SAFE STALL TIME IN SECONDS

ALLOWABLE STARTS PER HOUR

SOUND PRESSURE LEVEL @ 3 FT dB(A)

COLD	HOT	COLD	HOT	
18	13	2	1	

APPROVED:	M. PRATER	DRAWING NO.	3A057DHP12565	REVISION 0
-----------	------------------	-------------	----------------------	-------------------

DATE:
February 16, 2007

CONNECTION DIAGRAM



SCHEMATIC - Δ / Y CONNECTION

ACROSS THE LINE CONNECTION



WYE START-DELTA RUN CONNECTION

