

TYPE	OUTPUT		POLE	TIME RATING CNT.	VOLTAGE V	Hz	SYN SPEED R.P.M
	HP.	KW.					
ASHH	150	111.9	6		460	60	1200

DRIP PROOF TYPE, SQUIRREL-CAGE ROTOR

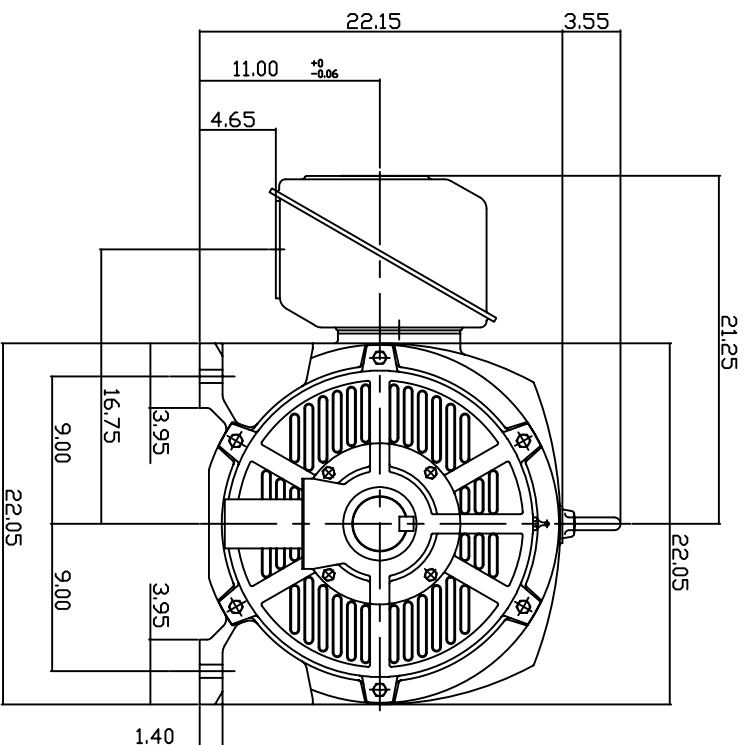
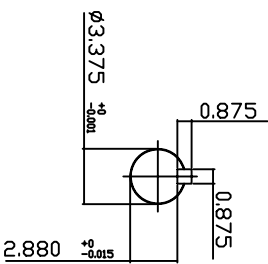
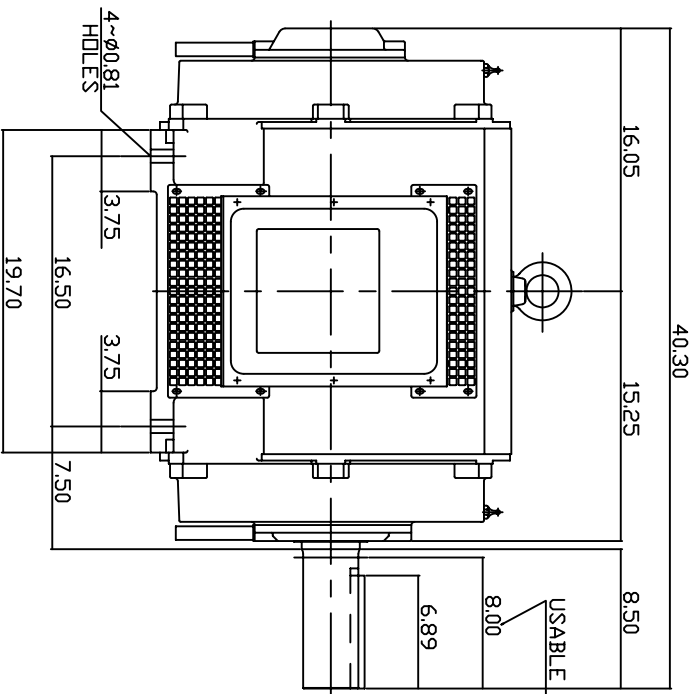

NOTE:

1. DIMENSIONS IN INCH.
2. FRAME ND445T
3. F CLASS INSULATION, S.F.115
4. FOR DIRECT DRIVE
5. BEARING SIZE: DRIVE END: 6318  
NON-DRIVE END: 6316
6. MOTOR APPROX. WEIGHT: 1430LBS

TB-56SSC

DWN.	V.L.LIN	MAR-26-2003
CHKD.	W.L.LIN	MAR-26-2003
APPD.	C.VANG	MAR-26-2003

DATE May 14, 2007

Co.t. #: DHP1506

OUTLINE DIMENSIONS

3-PHASE INDUCTION MOTOR



DWG NO. REV: 00

3A040T261

# TECO Westinghouse

ISSUED <b>05/07/07</b>	<b>PERFORMANCE DATA</b> <b>3-PHASE INDUCTION MOTOR</b>	ENCLOSURE <b>ODP</b>
TYPE <b>ASHH</b>		CATALOG# <b>DHP1506</b>

### NAMEPLATE INFORMATION

OUTPUT		POLE	FRAME SIZE	VOLTAGE	HZ	RATED AMBIENT	INS. CLASS	NEMA DESIGN	TIME RATING	SERVICE FACTOR
HP	KW									
<b>150</b>	<b>112</b>	<b>6</b>	<b>445T</b>	<b>460</b>	<b>60</b>	<b>40°C</b>	<b>F</b>	<b>B</b>	<b>CONT.</b>	<b>1.15</b>

### TYPICAL PERFORMANCE

FULL LOAD RPM	EFFICIENCY				POWER FACTOR			MAXIMUM POWER FACTOR CORRECTION
	FULL LOAD		3/4 LOAD	1/2 LOAD	F. L.	3/4 LOAD	1/2 LOAD	
	MIN. %	NOM. %	%	%	%	%	%	
<b>1181</b>	<b>94.5</b>	<b>95.4</b>	<b>95.0</b>	<b>93.9</b>	<b>82.5</b>	<b>78.5</b>	<b>74.8</b>	<b>55 KVAR</b>

CURRENTS			NEMA KVA CODE LETTER
NO LOAD	FULL LOAD	LOCKED ROTOR	
<b>69.6</b>	<b>178</b>	<b>1085</b>	<b>G</b>

TORQUE				INERTIA			ACCEL TIME	
FULL LOAD lb-ft	LOCKED ROTOR %FLT	PULL UP %FLT	BREAK DOWN %FLT	ROTOR WR <sup>2</sup> lb-ft <sup>2</sup>	NEMA LOAD WK <sup>2</sup> lb-ft <sup>2</sup>	MAX ALLOWABLE WK <sup>2</sup> lb-ft <sup>2</sup>	NEMA LOAD WK <sup>2</sup> Sec	MAX ALLOWABLE WK <sup>2</sup> Sec
<b>667</b>	<b>130</b>	<b>109</b>	<b>205</b>	<b>58</b>	<b>1719</b>	<b>4298</b>	<b>6.29</b>	<b>15.41</b>

SAFE STALL TIME IN SECONDS		ALLOWABLE STARTS PER HOUR		SOUND PRESSURE LEVEL @ 3 FT dB(A)
COLD	HOT	COLD	HOT	
<b>18</b>	<b>13</b>	<b>2</b>	<b>1</b>	<b>78</b>

APPROVED:	<b>M. PRATER</b>	DRAWING NO.	<b>3A057DHP1506</b>	REVISION <b>0</b>
-----------	------------------	-------------	---------------------	-------------------

DATE:  
February 16, 2007

# CONNECTION DIAGRAM

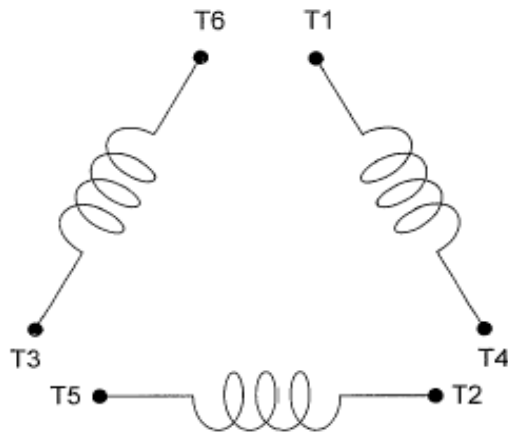

**SCHEMATIC -  $\Delta$  / Y CONNECTION**

## ACROSS THE LINE CONNECTION

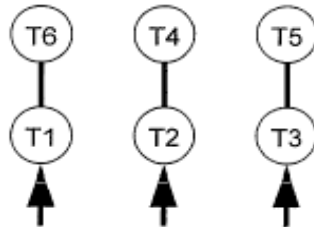

**460 VOLT CONNECTION**

## WYE START-DELTA RUN CONNECTION

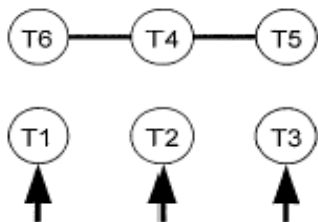

**LINE  
460 VOLT START**

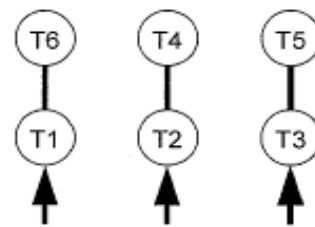

**LINE  
460 VOLT RUN**