

TYPE	OUTPUT		POLE	TIME RATING	VOLTAGE V	Hz	SYN SPEED R.P.M
	HP.	KW.					
ASHH	200	150	6	CDNT.	575	60	1200

DRIP PROOF TYPE, SQUIRREL-CAGE ROTOR

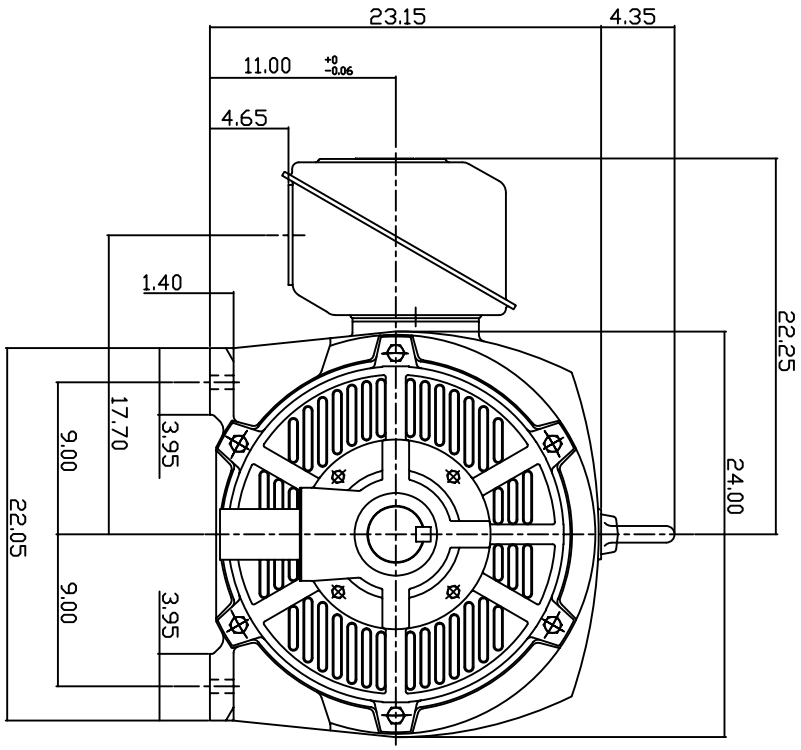
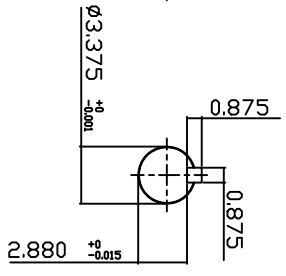
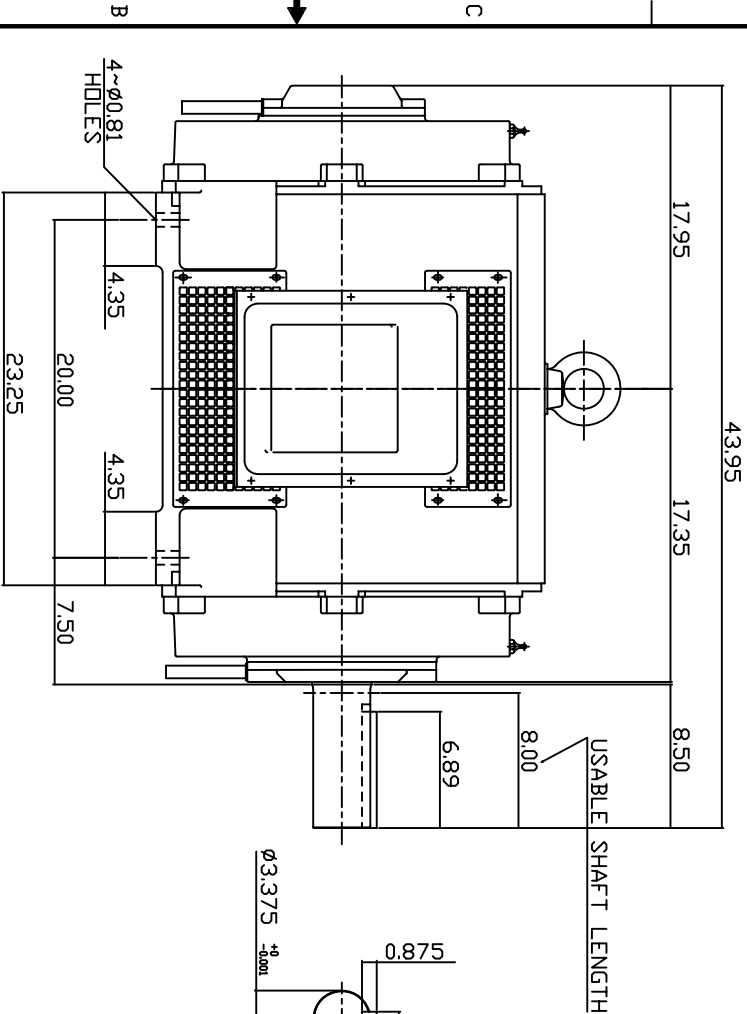

NOTE:

1. DIMENSIONS IN INCH.
2. FRAME NO. 447T
3. F CLASS INSULATION, S.F.1.15
4. FOR DIRECT DRIVE APPLICATIONS
5. BEARING SIZE: DRIVE END: 6320
NON-DRIVE END: 6318
6. MOTOR APPROX. WEIGHT: 1810 LBS

TB-56SC

DVN.	W.LLIN	MAR. 26. 2003
CHKD.	W.LLIN	MAR. 26. 2003
APPD.	C.WANG	MAR. 26. 2003

DATE	May 14 2007	OUTLINE DIMENSIONS
CATALOG NO.	DHP20065	
3-PHASE INDUCTION MOTOR		REV: 00
Dwg NO. 3A040T263		



6 5 4 3 2 1

TECO Westinghouse

ISSUED June 7, 2007	PERFORMANCE DATA	ENCLOSURE ODP
TYPE ASHH	3-PHASE INDUCTION MOTOR	CATALOG# DHP20065

NAMEPLATE INFORMATION

OUTPUT		POLE	FRAME SIZE	VOLTAGE	HZ	RATED AMBIENT	INS. CLASS	NEMA DESIGN	TIME RATING	SERVICE FACTOR
HP	KW									
200	149.2	6	447T	575	60	40°C	F	B	CONT.	1.15

TYPICAL PERFORMANCE

FULL LOAD RPM	EFFICIENCY				POWER FACTOR			MAXIMUM POWER FACTOR CORRECTION
	FULL LOAD		3/4 LOAD %	1/2 LOAD %	F. L. %	3/4 LOAD %	1/2 LOAD %	
	MIN. %	NOM. %						
1182	94.5	95.4	95.0	94.1	83.0	79.8	76.0	57.0 KVAR

CURRENTS

NO LOAD		FULL LOAD			LOCKED ROTOR			NEMA KVA CODE LETTER
AT 575 VOLT		AT 575 VOLT			AT 575 VOLT			
79.80			189.00			1160.00	G	

TORQUE

INERTIA

ACCEL TIME

FULL LOAD lb-ft	LOCKED ROTOR %FLT	PULL UP %FLT	BREAK DOWN %FLT	ROTOR WR ² lb-ft ²	NEMA LOAD WK ² lb-ft ²	MAX ALLOWABLE WK ² lb-ft ²	NEMA LOAD WK ² Sec	MAX ALLOWABLE WK ² Sec
888	130	109	205	119	2238	5595	6.27	15.20

SAFE STALL TIME IN SECONDS

ALLOWABLE STARTS PER HOUR

SOUND PRESSURE LEVEL @ 3 FT dB(A)

COLD	HOT	COLD	HOT	80
18	13	2	1	

APPROVED:	M. PRATER	DRAWING NO.	3A057DHP20065	REVISION 0
-----------	------------------	-------------	----------------------	-------------------

DATE:
February 16, 2007

CONNECTION DIAGRAM



SCHEMATIC - Δ / Y CONNECTION

ACROSS THE LINE CONNECTION



460 VOLT CONNECTION

WYE START-DELTA RUN CONNECTION



**LINE
460 VOLT START**



**LINE
460 VOLT RUN**