

TYPE	OUTPUT		POLE	TIME RATING	VOLTAGE	Hz	SYN.SPEED R.P.M
	HP.	KW.					
ASHH	250	186.5	4	CDNT.	460	60	1800

DRIP PROOF TYPE, SQUIRREL-CAGE ROTOR

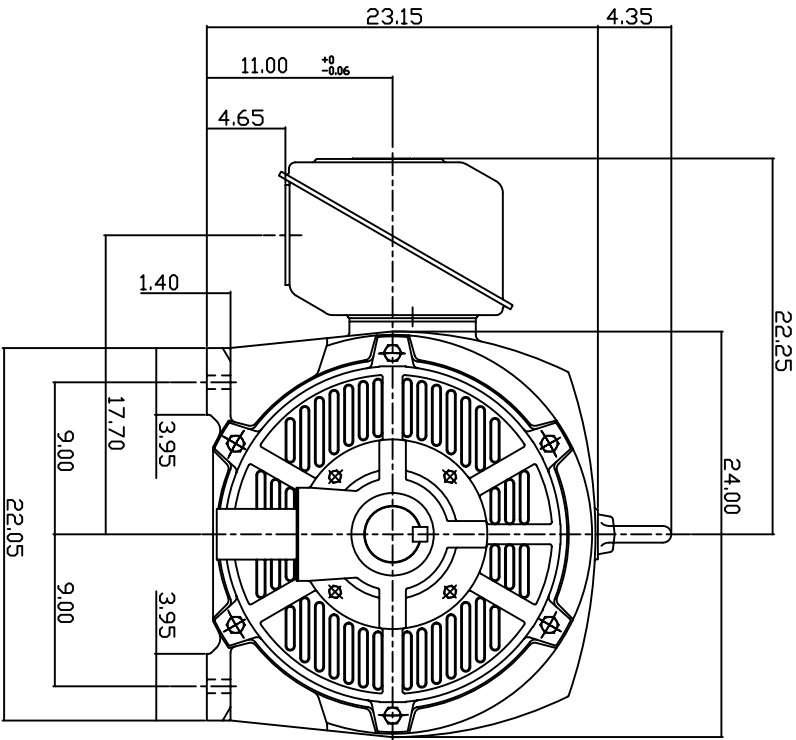
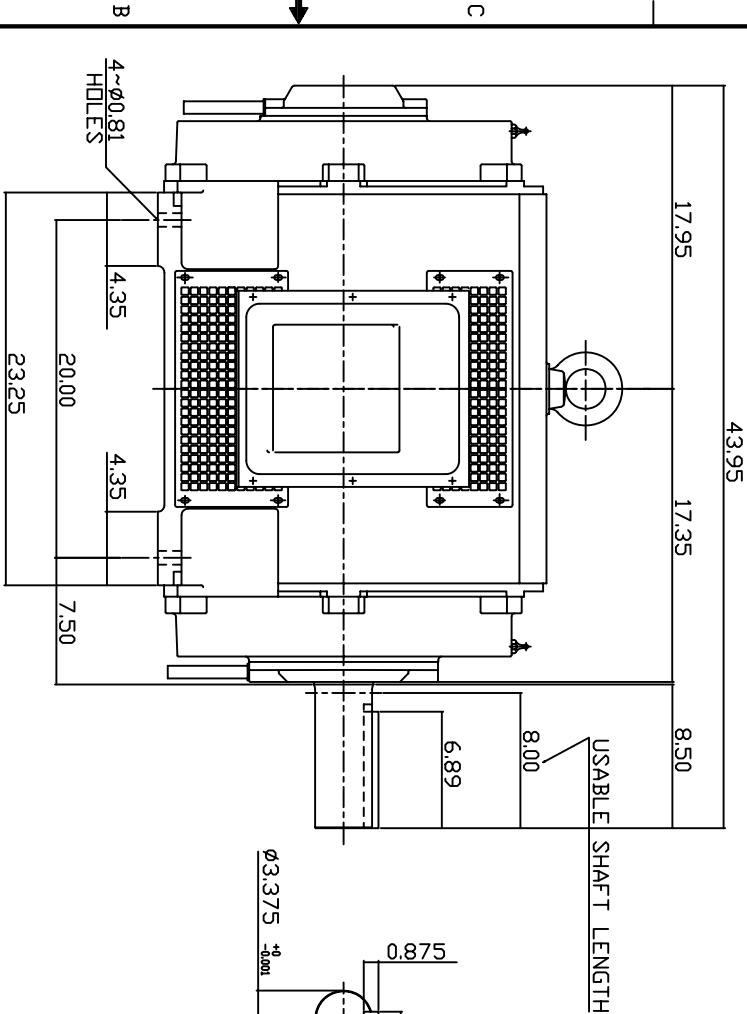

NOTE:  
1. DIMENSIONS IN INCH.  
2. FRAME NO. 447T  
3. F CLASS INSULATION, S.F.1.15  
4. FOR BELT DRIVE APPLICATIONS  
5. BEARING SIZE: DRIVE END: NU320  
NON-DRIVE END: 6318  
6. MOTOR APPRX. WEIGHT: 1810 LBS

- DIMENSIONS IN INCH.
- FRAME NO. 447T
- F CLASS INSULATION, S.F.1.15
- FOR BELT DRIVE APPLICATIONS
- BEARING SIZE: DRIVE END: NU320  
NON-DRIVE END: 6318
- MOTOR APPRX. WEIGHT: 1810 LBS

TB-565C

DWN.	W.LLIN	MAR-26-2003
CHKD.	W.LLIN	MAR-26-2003
APPD.	C.WANG	MAR-26-2003

DATE	February 24, 2007	OUTLINE DIMENSIONS
CATALOG NO.	DHP2504R	
3-PHASE INDUCTION MOTOR		DWG NO.
		3A040T263-1

TEC Westinghouse  
REV. 00

# TECO Westinghouse

ISSUED <b>05/07/07</b>	<b>PERFORMANCE DATA</b>	ENCLOSURE <b>ODP</b>
TYPE <b>ASHH</b>	<b>3-PHASE INDUCTION MOTOR</b>	CATALOG# <b>DHP2504R</b>

### NAMEPLATE INFORMATION

OUTPUT		POLE	FRAME SIZE	VOLTAGE	HZ	RATED AMBIENT	INS. CLASS	NEMA DESIGN	TIME RATING	SERVICE FACTOR
HP	KW									
<b>250</b>	<b>187</b>	<b>4</b>	<b>447T</b>	<b>460</b>	<b>60</b>	<b>40°C</b>	<b>F</b>	<b>B</b>	<b>CONT.</b>	<b>1.15</b>

### TYPICAL PERFORMANCE

FULL LOAD RPM	EFFICIENCY				POWER FACTOR			MAXIMUM POWER FACTOR CORRECTION
	FULL LOAD		3/4 LOAD	1/2 LOAD	F. L.	3/4 LOAD	1/2 LOAD	
	MIN. %	NOM. %	%	%	%	%	%	
<b>1782</b>	<b>95</b>	<b>95.8</b>	<b>95.4</b>	<b>94.5</b>	<b>87</b>	<b>83.5</b>	<b>80.5</b>	<b>70 KVAR</b>

### CURRENTS

NO LOAD	FULL LOAD	LOCKED ROTOR	NEMA KVA CODE LETTER
<b>88.4</b>	<b>281</b>	<b>1825</b>	<b>G</b>

### TORQUE

### INERTIA

### ACCEL TIME

FULL LOAD lb-ft	LOCKED ROTOR %FLT	PULL UP %FLT	BREAK DOWN %FLT	ROTOR WR <sup>2</sup> lb-ft <sup>2</sup>	NEMA LOAD WK <sup>2</sup> lb-ft <sup>2</sup>	MAX ALLOWABLE WK <sup>2</sup> lb-ft <sup>2</sup>	NEMA LOAD WK <sup>2</sup> Sec	MAX ALLOWABLE WK <sup>2</sup> Sec
<b>737</b>	<b>125</b>	<b>105</b>	<b>205</b>	<b>65</b>	<b>1017</b>	<b>2034</b>	<b>5.28</b>	<b>10.25</b>

SAFE STALL TIME IN SECONDS

ALLOWABLE STARTS PER HOUR

SOUND PRESSURE LEVEL @ 3 FT dB(A)

COLD	HOT	COLD	HOT	82
<b>18</b>	<b>12</b>	<b>2</b>	<b>1</b>	

APPROVED:

**M. PRATER**

DRAWING NO.

**3A057DHP2504R**

REVISION **0**

DATE:  
February 16, 2007

# CONNECTION DIAGRAM



**SCHEMATIC - Δ / Y CONNECTION**

## ACROSS THE LINE CONNECTION



**460 VOLT CONNECTION**

## WYE START-DELTA RUN CONNECTION



**LINE  
460 VOLT START**

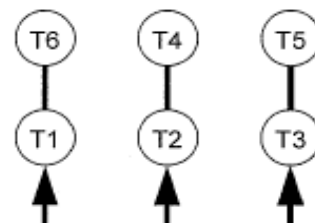

**LINE  
460 VOLT RUN**