

TYPE	OUTPUT		POLE	TIME RATING	VOLTAGE V	Hz	SYN SPEED R.P.M
	HP.	KW.					
ASHH	300	224	4	CDNT.	575	60	1800

DRIP PROOF TYPE, SQUIRREL-CAGE ROTOR

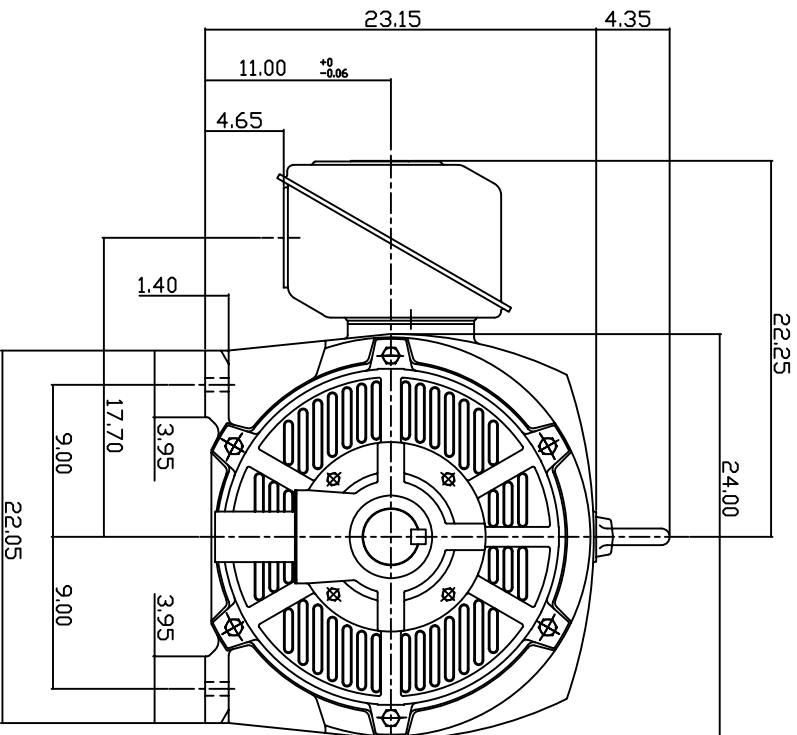
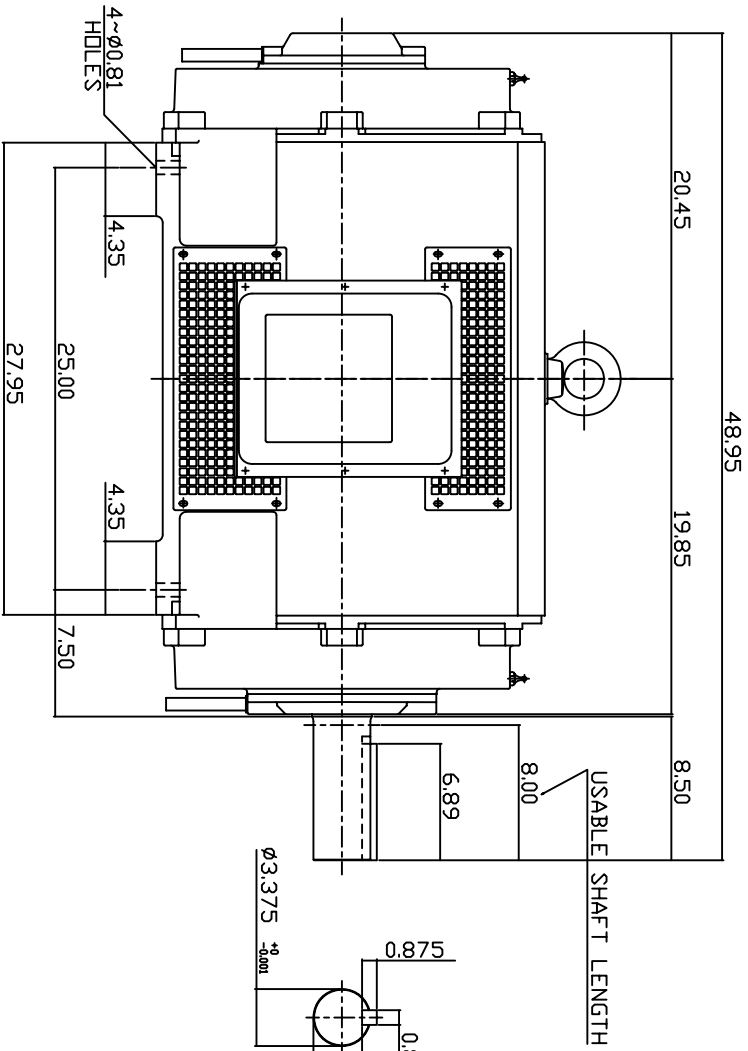

NOTE:

1. DIMENSIONS IN INCH.
2. FRAME NO. 449T
3. F CLASS INSULATION, S.F.1.15
4. FOR DIRECT FLEXIBLE COUPLING
5. BEARING SIZE: DRIVE END: 6320
NON-DRIVE END: 6318
6. MOTOR APPROX. WEIGHT: 1870 LBS

TB-56SC

DWN.	W.LLIN	MAR. 26. 2003
CHKD.	W.LLIN	MAR. 26. 2003
APPD.	C.WANG	MAR. 26. 2003

DATE	February 24, 2007	OUTLINE DIMENSIONS
CATALOG NO.	DHP30045	
3-PHASE INDUCTION MOTOR		DWG NO.



3A040T265-1 REV: 00

TECO Westinghouse

ISSUED June 7, 2007	PERFORMANCE DATA	ENCLOSURE ODP
TYPE ASHH	3-PHASE INDUCTION MOTOR	CATALOG# DHP30045

NAMEPLATE INFORMATION

OUTPUT		POLE	FRAME SIZE	VOLTAGE	HZ	RATED AMBIENT	INS. CLASS	NEMA DESIGN	TIME RATING	SERVICE FACTOR
HP	KW									
300	223.8	4	449T	575	60	40°C	F	B	CONT.	1.15

TYPICAL PERFORMANCE

FULL LOAD RPM	EFFICIENCY				POWER FACTOR			MAXIMUM POWER FACTOR CORRECTION
	FULL LOAD		3/4 LOAD %	1/2 LOAD %	F. L. %	3/4 LOAD %	1/2 LOAD %	
	MIN. %	NOM. %						
1783	95.0	95.8	95.4	94.5	87.5	84.0	81.0	64.0 KVAR

CURRENTS

NO LOAD		FULL LOAD			LOCKED ROTOR			NEMA KVA CODE LETTER
AT 575 VOLT		AT 575 VOLT			AT 575 VOLT			
79.80		268.00		1760.00			G	

TORQUE

INERTIA

ACCEL TIME

FULL LOAD lb-ft	LOCKED ROTOR %FLT	PULL UP %FLT	BREAK DOWN %FLT	ROTOR WR ² lb-ft ²	NEMA LOAD WK ² lb-ft ²	MAX ALLOWABLE WK ² lb-ft ²	NEMA LOAD WK ² Sec	MAX ALLOWABLE WK ² Sec
883	125	105	205	73	1197	2394	5.18	10.06

SAFE STALL TIME IN SECONDS

ALLOWABLE STARTS PER HOUR

SOUND PRESSURE LEVEL @ 3 FT dB(A)

COLD	HOT	COLD	HOT	82
18	13	2	1	

APPROVED:	M. PRATER	DRAWING NO.	3A057DHP30045	REVISION 0
-----------	------------------	-------------	----------------------	-------------------

DATE:
February 16, 2007

CONNECTION DIAGRAM

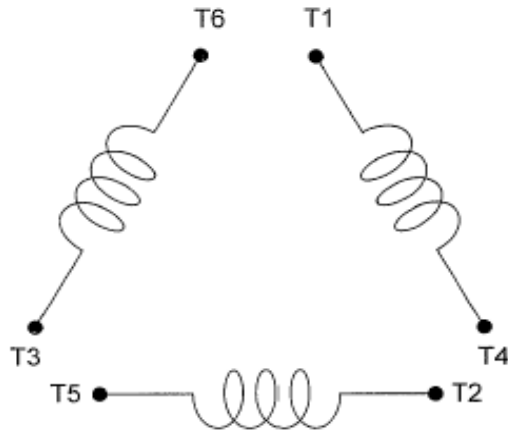

SCHEMATIC - Δ / Y CONNECTION

ACROSS THE LINE CONNECTION

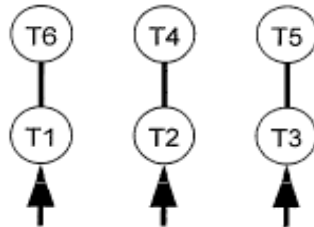

460 VOLT CONNECTION

WYE START-DELTA RUN CONNECTION

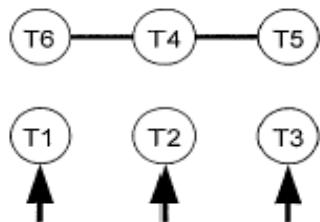

**LINE
460 VOLT START**

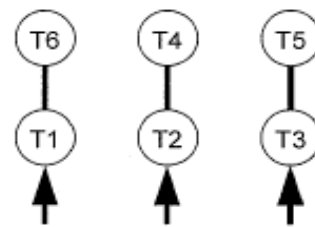

**LINE
460 VOLT RUN**