

TYPE	OUTPUT		POLE	TIME RATING	VOLTAGE V	Hz	SYN SPEED R.P.M
	HP.	KW.					
ASHH	500	373	2	CDNT.	460	60	3600

DRIP PROOF TYPE, SQUIRREL-CAGE ROTOR

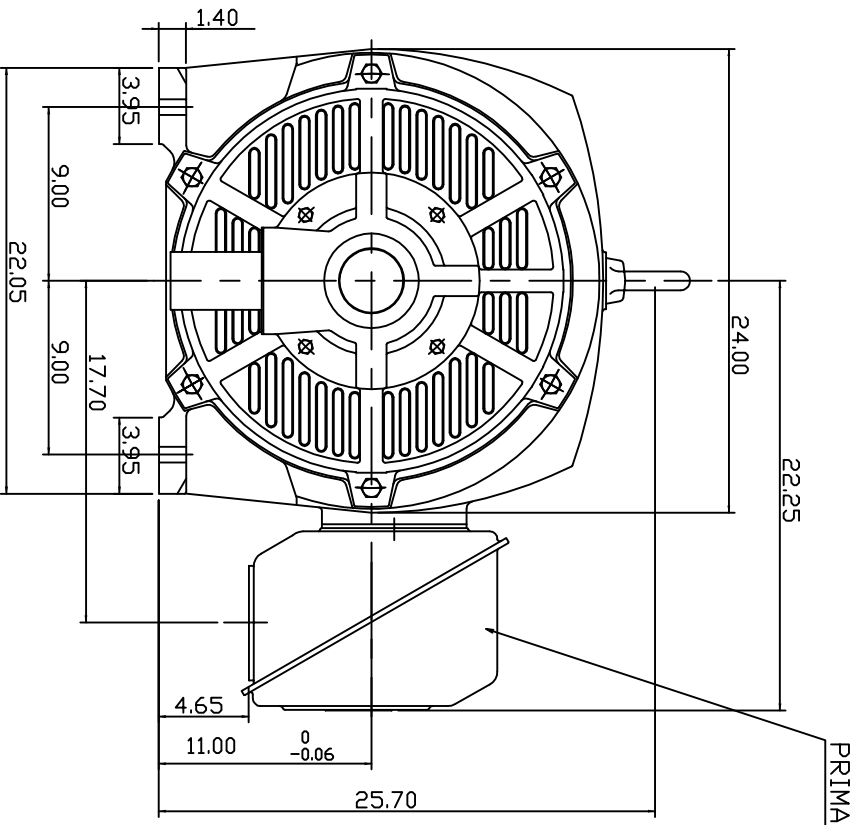

PRIMARY T-BOX

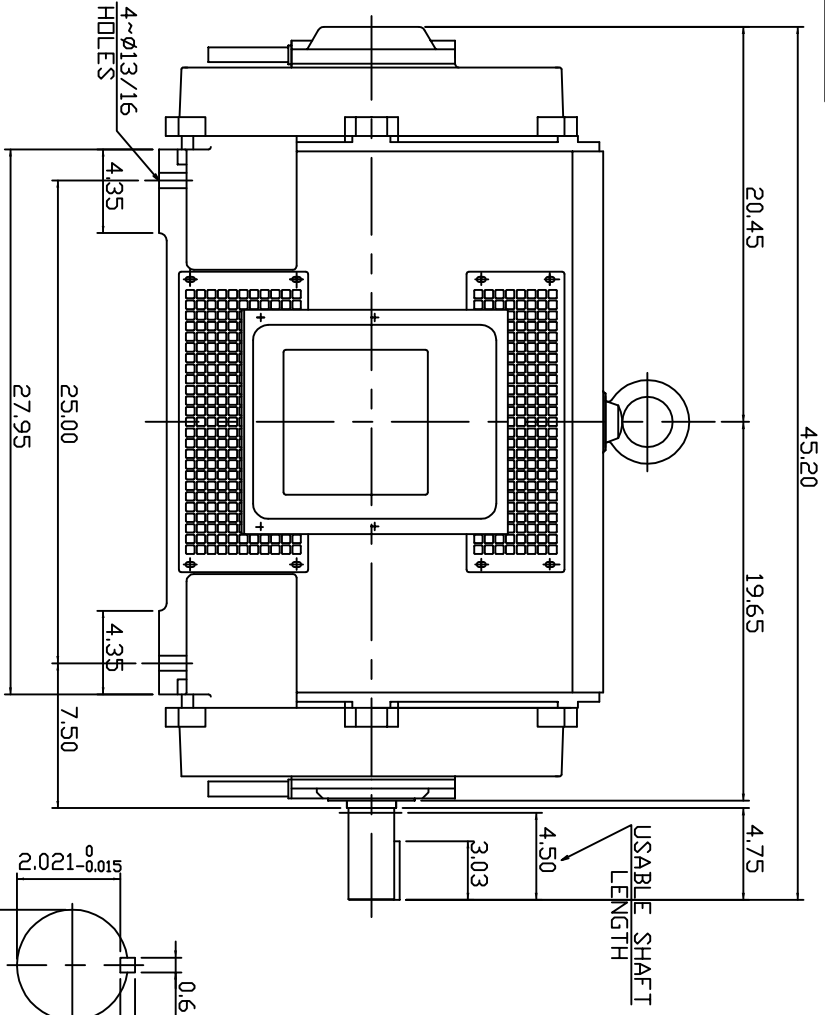

USABLE SHAFT LENGTH

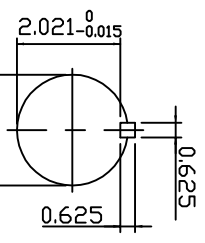

- NOTE:
1. DIMENSIONS IN INCH
 2. FRAME NO. 449TS
 3. F CLASS INSULATION
 4. FOR DIRECT FLEXIBLE COUPLING
 5. ENCLASURE: IP22
 6. BEARING SIZE: DPP, DRIVE END 6315C3
DPP, DRIVE END 6315C3
 7. MOTOR APPROX. WEIGHT: 2225 LBS

TB-56SC

DWN.	HCHEN	JUL - 05 - 2010
CHKD.	W.V/ENG	JUL - 05 - 2010
APPD.	T.H/STAD	JUL - 05 - 2010

DATE	JUL Y 9, 2010	OUTLINE DIMENSIONS
CATALOG NO.	DHP5002	3-PHASE INDUCTION MOTOR



DWG NO. 3A049DTA0013-4
REV: 00

SHAFT END
[ENLARGE VIEW]

TECO Westinghouse

ISSUED 07/09/10	PERFORMANCE DATA	ENCLOSURE ODP
TYPE ASHH	3-PHASE INDUCTION MOTOR	CATALOG# DHP5002

NAMEPLATE INFORMATION

OUTPUT		POLE	FRAME SIZE	VOLTAGE	HZ	RATED AMBIENT	INS. CLASS	NEMA DESIGN	TIME RATING	SERVICE FACTOR
HP	KW									
500	373	2	449TS	460	60	40°C	F	B	CONT.	1.15

TYPICAL PERFORMANCE

FULL LOAD RPM	EFFICIENCY				POWER FACTOR			MAXIMUM POWER FACTOR CORRECTION
	FULL LOAD		3/4 LOAD %	1/2 LOAD %	F. L. %	3/4 LOAD %	1/2 LOAD %	
	MIN. %	NOM. %						
3572	95.0	95.8	95.6	95.4	91.2	89.0	85.0	109 KVAR

CURRENTS

NO LOAD	FULL LOAD	LOCKED ROTOR	NEMA KVA CODE LETTER
137.3	536	3625	G

TORQUE

INERTIA

ACCEL TIME

FULL LOAD lb-ft	LOCKED ROTOR %FLT	PULL UP %FLT	BREAK DOWN %FLT	ROTOR WR ² lb-ft ²	NEMA LOAD WK ² lb-ft ²	MAX ALLOWABLE WK ² lb-ft ²	NEMA LOAD WK ² Sec	MAX ALLOWABLE WK ² Sec
735	140	120	225	44.4	-	381	-	3.82

SAFE STALL TIME IN SECONDS

ALLOWABLE STARTS PER HOUR

SOUND PRESSURE LEVEL @ 3 FT dB(A)

COLD	HOT	COLD	HOT	85
20	15	2	1	

APPROVED:

M. PRATER

DRAWING NO.

3A057DHP5002

REVISION **0**

DATE:
February 16, 2007

CONNECTION DIAGRAM

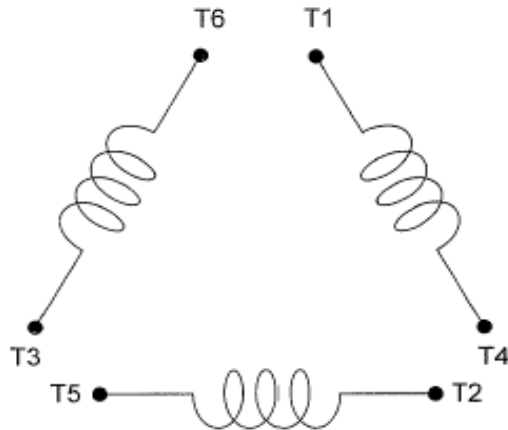

SCHEMATIC - Δ / Y CONNECTION

ACROSS THE LINE CONNECTION

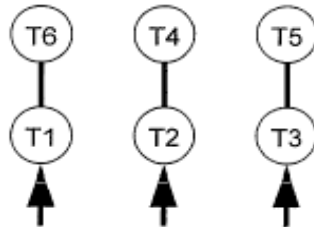

460 VOLT CONNECTION

WYE START-DELTA RUN CONNECTION

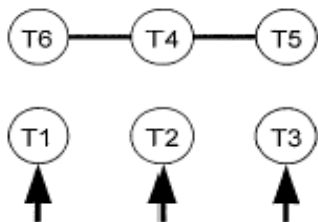

**LINE
460 VOLT START**

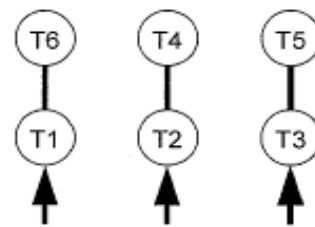

**LINE
460 VOLT RUN**