

BALDOR® • RELIANCE 

Product Information Packet

DRX25164T

10HP, 1180//980RPM, 3PH, 60HZ, 256T, XPFC, F1

Part Detail							
Revision:	E	Status:	PRD/A	Change #:		Proprietary:	No
Type:	AC	Elec. Spec:	09WGZ383	CD Diagram:	CD0005	Mfg Plant:	
Mech. Spec:		Layout:	09LY-000-552	Poles:	06	Created Date:	05-30-2019
Base:		Eff. Date:	10-27-2020	Leads:	9#12		

Specs			
Catalog Number:	DRX25164T	Duty Rating:	CONT
Enclosure:	XPFC	Electrically Isolated Bearing:	Not Electrically Isolated
Frame:	256T	Feedback Device:	NO FEEDBACK
Frame Material:	Iron	Heater Indicator:	No Heater
Output @ Frequency:	7.500 HP @ 50 HZ	Insulation Class:	F
	10.000 HP @ 60 HZ	Inverter Code:	Inverter Duty
Synchronous Speed @ Frequency:	1200 RPM @ 60 HZ	IP Rating:	NONE
Voltage @ Frequency:	190.0 V @ 50 HZ	KVA Code:	J
	230.0 V @ 60 HZ	Lifting Lugs:	Standard Lifting Lugs
	380.0 V @ 50 HZ	Locked Bearing Indicator:	Locked Bearing
	460.0 V @ 60 HZ	Motor Lead Termination:	Flying Leads
XP Class and Group:	CLI GP C,D	Motor Type:	0956M
XP Division:	Division I	Mounting Arrangement:	F1
Agency Approvals:	UR	Power Factor:	70
	CSA EEV	Product Family:	Hazardous Location Motor
	CSA	Pulley Face Code:	Standard
Auxillary Box:	No Auxillary Box	Rodent Screen:	None
Auxillary Box Lead Termination:	None	RoHS Status:	ROHS NON-COMPLIANT

Base Indicator:	Rigid	Shaft Ground Indicator:	No Shaft Grounding
Bearing Grease Type:	Polyrex EM (-20F +300F)	Shaft Rotation:	Reversible
Blower:	None	Speed Code:	Single Speed
Constant Torque Speed Range:	6	Motor Standards:	NEMA
Current @ Voltage:	30.400 A @ 208.0 V	Starting Method:	Direct on line
	30.000 A @ 230.0 V	Thermal Device - Bearing:	None
	28.000 A @ 190.0 V	Thermal Device - Winding:	Normally Closed Thermostat
	15.000 A @ 460.0 V	Vibration Sensor Indicator:	No Vibration Sensor
	14.000 A @ 380.0 V	Winding Thermal 1:	None
Design Code:	A	Winding Thermal 2:	None
Drip Cover:	No Drip Cover	XP Temp Code:	T3C

Nameplate NP1401XPSLEV										
NO.						CC	010A			
S/N						TEMP CODE	T3C			
SPEC.	09-0000-1381					INV.TYPE	PWM			
CAT.NO.	DRX25164T					C HP FR	60	C HP TO	90	
HP	10//7.5					CT HZ FROM	6	CT HZ TO	60	
VOLTS	230/460//190/380					VT HZ FROM	6	VT HZ TO	60	
AMPS	30/15//28/14					MAG CUR	15.8/7.9			
RPM	1180//980					MX RPM	1800			
HZ	60//50	PH	3	CL	F	NOM.EFF.	91			
SER.F.	1.00	DES	A	SL HZ	1	WK2	4.5			
FRAME	256T	RATING	40C AMB-CONT							
55C AMB @ 1.0 SF, 60C RISE										
1.15SF ON SINEWAVE					NEMA MG-1 PT.5,IP55					

Parts List		
Part Number	Description	Quantity
SA370313	SA 09-0000-1381	1.000 EA
RA359958	RA 09-0000-1381	1.000 EA
LB1115N	LABEL,LIFTING DEVICE (ON ROLLS)	1.000 EA
LC0005E01	SPL CONN.DIA./WARN.LABEL(LC0005/LB1119)	1.000 EA
NP1401XPSLEV	SS XP INV UL CSA-EEV CC CL-I GP-C&D	1.000 EA
85XU0407S04	4X1/4 U DRIVE PIN STAINLESS	2.000 EA
85XU0407S04	4X1/4 U DRIVE PIN STAINLESS	4.000 EA
MN416A01	TAG-INSTAL-MAINT no wire (2100/bx) 4/22	1.000 EA
LB1081Z	ALUM XP CAUTION LABEL (ZK PLANT ONLY-	1.000 EA
HW3201A01	1/2-13 EYEBOLT	1.000 EA
HW1002A63	WASHER, 5/8 HI-COLLAR SPRLCKWASHER	1.000 EA
09FH1004A08P	FAN COVER, MACH W/EPOXY PRIMER	1.000 EA
HW1001A25	LOCKWASHER 1/4, ZINC PLT .493 OD, .255 I	3.000 EA
10XN2520K14	1/4-20 X .88 HEX GRD 5 (20001)	3.000 EA
09FN3001D01SP	EXTERNAL FAN, PLASTIC (COMES W/SCREW FRO	1.000 EA
HW2500A25	WOODRUFF KEY USA #1008 #BLOW CARBON STEE	1.000 EA
LD7020D09	LEAD SET, 12AWG, 9 LEAD, 20" LONG LEADS	1.000 EA
MJ1000A02	GREASE, MOBIL POLYREX EM - 124047	0.080 LB
09EP1700A65PP15	FR ENDPLATE, MACH, XPFC W/DRN HW4505A02	1.000 EA
10XN3816K28	3/8-16 X 1.75 HEX HD CAP SCREW, GRADE 5	4.000 EA
HW1001A38	LOCKWASHER 3/8, ZINC PLT .688 OD, .382 I	4.000 EA
HA2065A03	SLINGER, ALUM.	1.000 EA
80XN1032A07	SET SCREW, HEX XOCK, ZN	1.000 EA
HW5100A08	W3118-035 WVY WSHR (WB)	1.000 EA

Parts List (continued)		
Part Number	Description	Quantity
HA4017A03	.125 X 1.75 GREASE EXT (F/S)	1.000 EA
HA4017A08	.125X3.50 GREASER EXTEN.	1.000 EA
HW4019A01	PIPE COUPLING 1/8 NPT,STEEL,ZINC COATING	1.000 EA
HA4051A00	PLASTIC CAP FOR GREASE FITTING	1.000 EA
HW4500A21	1618BALEMITE FITTING 825 UNIVERSAL	1.000 EA
HW4500A20	1/8NPT SL PIPE PLUG	1.000 EA
HW4505A02	BREATHER/DRAIN-EXP PROOF-.250-18 PTF AIS	1.000 EA
HW3023E06	.125 X .625 SPIRAL SPRING PIN	1.000 EA
09EP1707A16P	PU E.P., MACH. W/DRAIN HW4505A02 W/PRIME	1.000 EA
HW1001A38	LOCKWASHER 3/8, ZINC PLT .688 OD, .382 I	4.000 EA
10XN3816K28	3/8-16 X 1.75 HEX HD CAP SCREW, GRADE 5	4.000 EA
HA2066A01	SLINGER, ALUM (AUTO)	1.000 EA
80XN1032A07	SET SCREW, HEX XOCK, ZN	1.000 EA
10XN2520K36	1/4-20 X 2.25" HX HD SCRWGRADE 5, ZINC P	4.000 EA
HA4051A00	PLASTIC CAP FOR GREASE FITTING	1.000 EA
HW4500A03	GREASE FITTING, .125 NPT 1610(ALEMITE) 8	1.000 EA
HW4500A20	1/8NPT SL PIPE PLUG	1.000 EA
HW4505A02	BREATHER/DRAIN-EXP PROOF-.250-18 PTF AIS	1.000 EA
HW3023E06	.125 X .625 SPIRAL SPRING PIN	1.000 EA
09CB1003A01P	KOBX, MACH 1.25 NPT GROUP C MTRS PRIMED	1.000 EA
10XN3118K24	5/16-18 X 1.50" HEX HD, GRADE 5	4.000 EA
HW1001A31	LOCKWASHER 5/16, ZINC PLT.591 OD, .319 I	4.000 EA
WD1000B25	GND LUG, BURNDY L125HP OR T&B L125HP-BB	1.000 EA
10XN3118K12	5/16-18 X .75 GRADE 5, ZINC PLATED	1.000 EA

Product Information Packet: DRX25164T - 10HP,1180//980RPM,3PH,60HZ,256T,XPFC,F1

HW1001A31	LOCKWASHER 5/16, ZINC PLT.591 OD, .319 I	1.000 EA
09CB1502A01P	CONDUIT BOX LID MACH. GROUP C MTRS W/EP	1.000 EA
84XN5013J24	1/2-13 X 1-1/2 HEX SOCKET HD CAP SCREW	6.000 EA
HW1001A50	LOCKWASHER 1/2, ZINC PLT, .879 OD, .509 I	6.000 EA
MG1025G29	WILKOFASST, 789.229, DARK CHARCOAL GRAY	0.070 GA
40PA1005	PACKAGING GROUP, 09 STD	1.000 EA
HW2501G25	KEY, 3/8 SQ X 2.875	1.000 EA
MJ5000A09	EFI KIT #1578 (400 ML CARTRIDGE OF EFI	0.031 EA
MJ5001A27	32220KN GRAY SEALER *MIN BUY 4 QTS=1GAL	0.001 QT

AC Induction Motor Performance Data

Record # 73723

Typical performance - not guaranteed values

Winding: 09WGZ383-R006		Type: 0956M		Enclosure: XPFC	
Nameplate Data			460 V, 60 Hz: High Voltage Connection		
Rated Output (HP)	10	Full Load Torque	44.4 LB-FT		
Volts	230/460	Start Configuration	direct on line		
Full Load Amps	29.2/14.6	Breakdown Torque	146 LB-FT		
R.P.M.	1180	Pull-up Torque	53.6 LB-FT		
Hz	60 Phase	3	Locked-rotor Torque	73.6 LB-FT	
NEMA Design Code	A KVA Code	J	Starting Current	95.3 A	
Service Factor (S.F.)		1	No-load Current	7.9 A	
NEMA Nom. Eff.	91 Power Factor	70	Line-line Res. @ 25°C	0.659 Ω	
Rating - Duty		40C AMB-CONT	Temp. Rise @ Rated Load	45°C	
S.F. Amps			Temp. Rise @ S.F. Load	53°C	
			Locked-rotor Power Factor	24.2	
			Rotor inertia	4.5 LB-FT ²	

Load Characteristics 460 V, 60 Hz, 10 HP

% of Rated Load	25	50	75	100	125	150
Power Factor	32	52	63	70	72	73
Efficiency	83.6	89.7	91.3	91.5	91.1	90.3
Speed	1196	1191	1186	1182	1176	1169
Line amperes	8.74	10.1	12.2	14.7	17.7	21

Performance Graph at 460V, 60Hz, 10.0HP Typical performance - Not guaranteed values

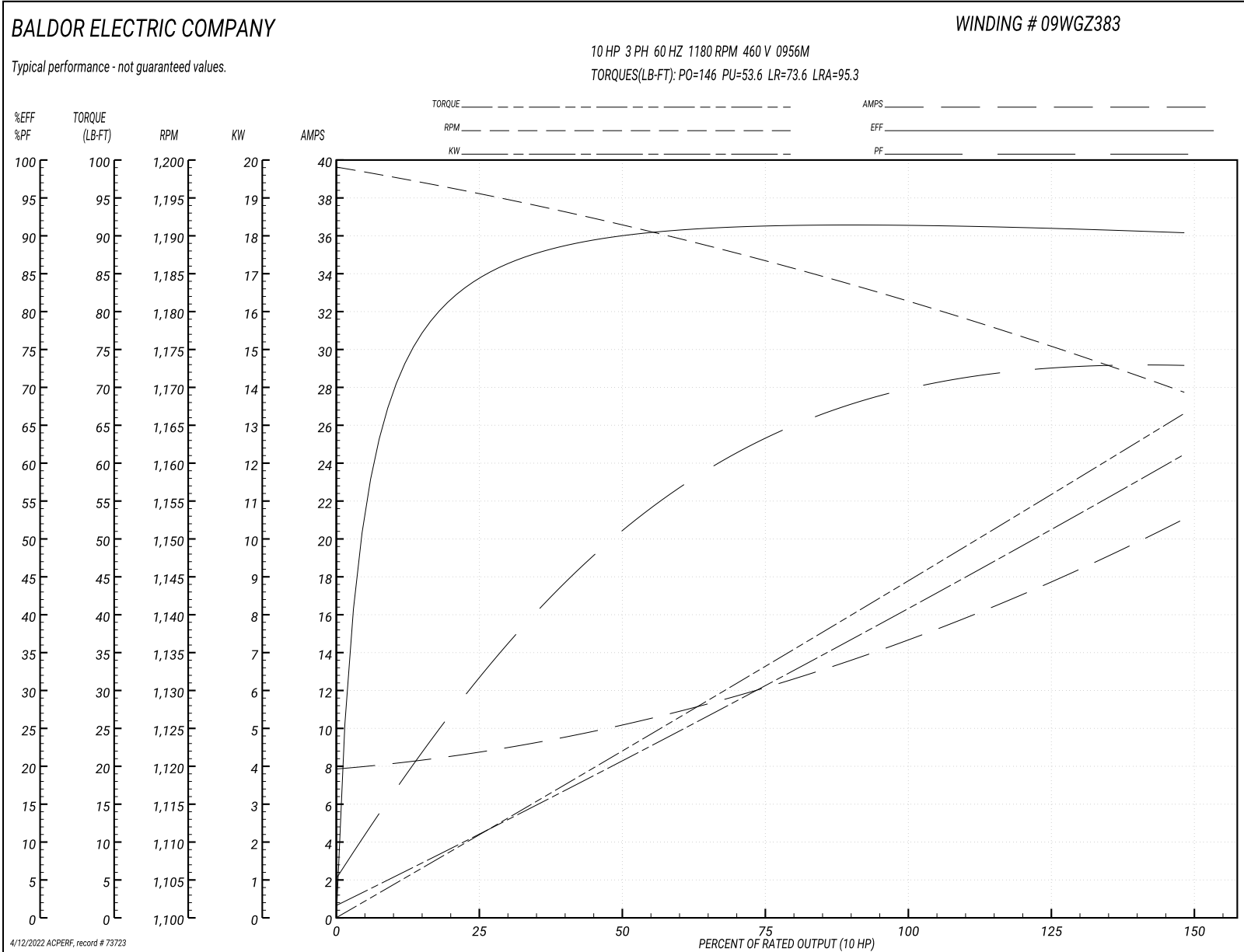

AC Induction Motor Performance Data

Record # 75809

Typical performance - not guaranteed values

Winding: 09WGZ383-R004		Type: 0956M		Enclosure: XPFC	
Nameplate Data			380 V, 50 Hz: High Voltage Connection		
Rated Output (HP)	10//7.5		Full Load Torque	40.04 LB-FT	
Volts	230/460//190/380		Start Configuration	direct on line	
Full Load Amps	30/15//28/14		Breakdown Torque	141 LB-FT	
R.P.M.	1180//980		Pull-up Torque	56.44 LB-FT	
Hz	60//50	Phase	3	Locked-rotor Torque	77.49 LB-FT
NEMA Design Code	A	KVA Code	J	Starting Current	93.43 A
Service Factor (S.F.)	1		No-load Current	7.77 A	
NEMA Nom. Eff.	91	Power Factor	70	Line-line Res. @ 25°C	0.659 Ω
Rating - Duty	40C AMB-CONT		Temp. Rise @ Rated Load	40°C	
S.F. Amps			Temp. Rise @ S.F. Load	48°C	
			Locked-rotor Power Factor	27.1	
			Rotor inertia	4.5 LB-FT ²	

Load Characteristics 380 V, 50 Hz, 7.5 HP

% of Rated Load	25	50	75	100	125	150
Power Factor	31	50	61	68	71	73
Efficiency	83	89.2	90.8	91.1	90.6	89.7
Speed	996	992	987	984	978	972
Line amperes	8.53	9.7	11.52	13.72	16.39	19.29

Performance Graph at 380V, 50Hz, 7.5HP Typical performance - Not guaranteed values

BALDOR ELECTRIC COMPANY

WINDING # 09WGZ383

Typical performance - not guaranteed values.

7.5 HP 3 PH 50 HZ 984 RPM 380 V 0956M

TORQUES(LB-FT): PO=141 PU=56.44 LR=77.49 LRA=93.43

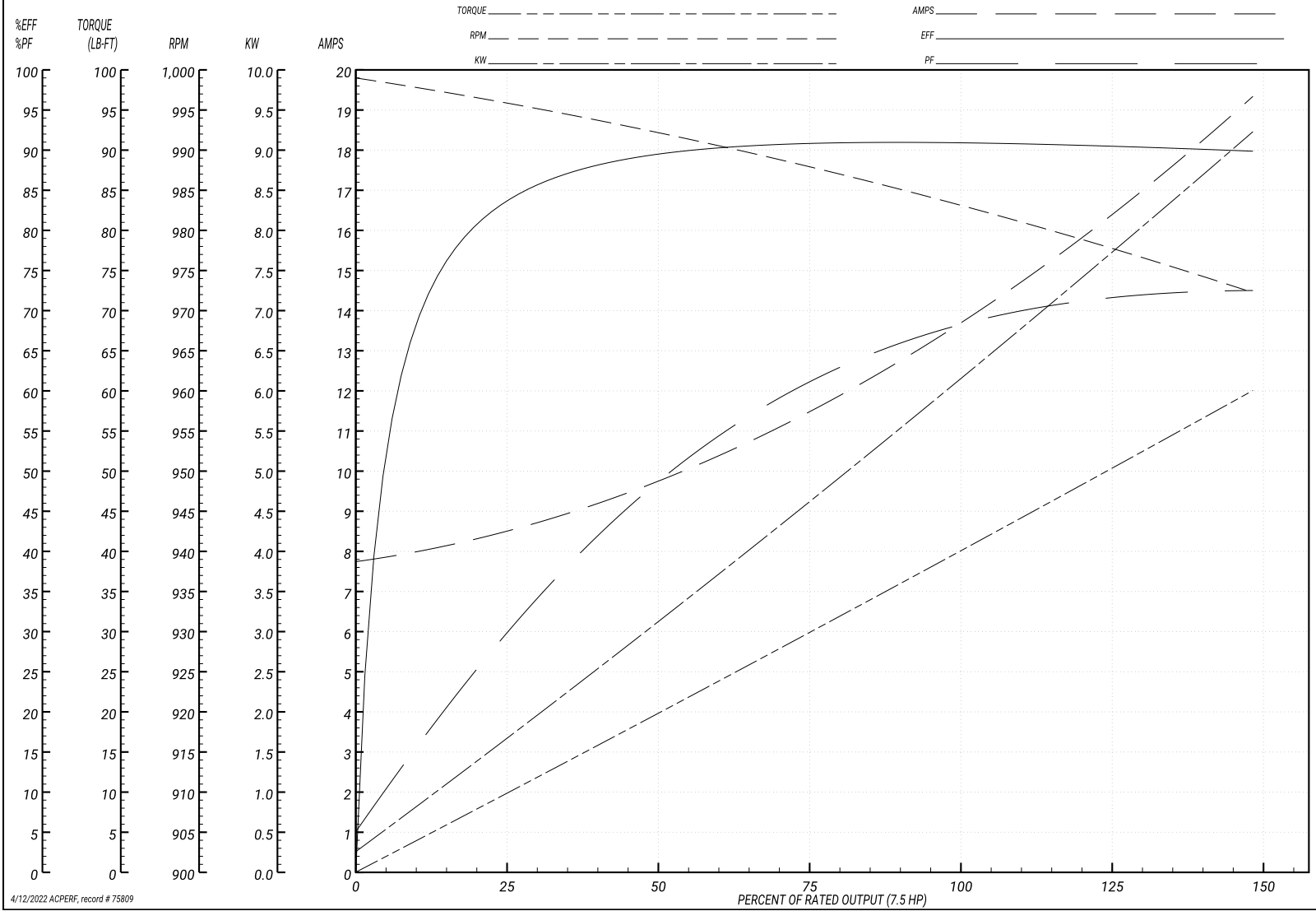

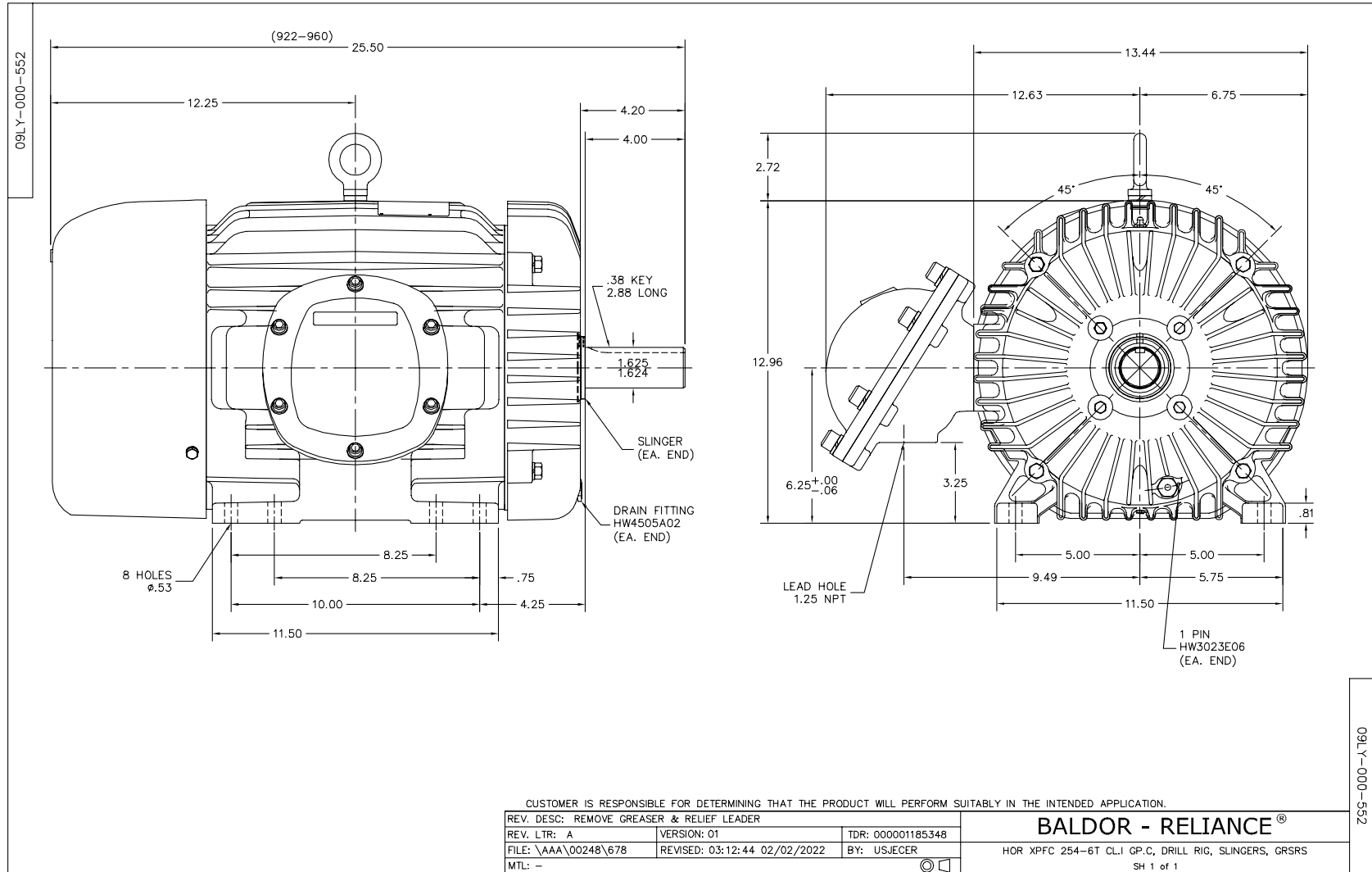

CD0005

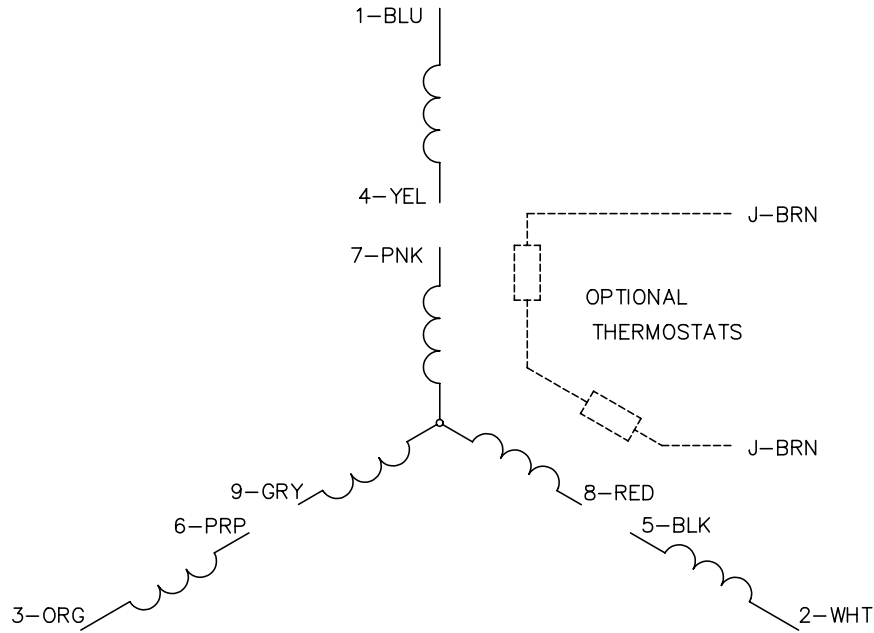

LOW VOLTAGE
(2Y)

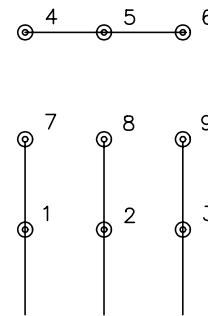

LINE

HIGH VOLTAGE
(1Y)

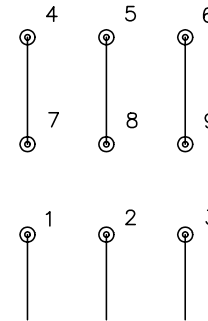

LINE

NOTES:

1. INTERCHANGE ANY TWO LINE LEADS TO REVERSE ROTATION.
2. OPTIONAL THERMOSTATS ARE PROVIDED WHEN SPECIFIED.
3. ACTUAL NUMBER OF INTERNAL PARALLEL CIRCUITS MAY BE A MULTIPLE OF THOSE SHOWN ABOVE.
4. LEAD COLORS ARE OPTIONAL. LEADS MUST ALWAYS BE NUMBERED AS SHOWN.

REV. DESC: REVISE TO SHOW OPTIONAL COLORS

REV. LTR: E BY: JLP

REVISED: 01/19/99 10:15

TDR: 0171435

90000

FILE: AAA00005140

MDL: -

MTL: -

BALDOR ELECTRIC Co.

3PH, DV, 9 LEADS

CD0005

Marketing maintained PDF of MN416:

<http://www.baldor.com/support/Literature/Load.ashx/MN416?ManNumber=MN416>