

DATE  
February 16, 2004

OUTLINE DIMENSIONS  
3-PHASE INDUCTION MOTOR

MODEL TYPE:  
ASGHPE

CATALOG NO.  
DSP0014

FRAME NO. A56

Pole	HP	KW	Hz	VOLT	Syn. Speed R. P. M
4	1	.75	60	230/460	1800

Ins.	Rating	Dimensions in	Approx Weight	Bearings
F	CONT.	inch	30.0 lbs	DE: 6204ZZ NDE: 6203ZZ

OPEN DRIP - PROOF

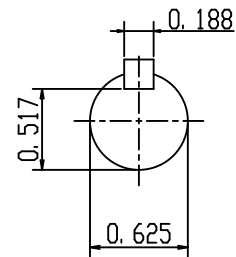
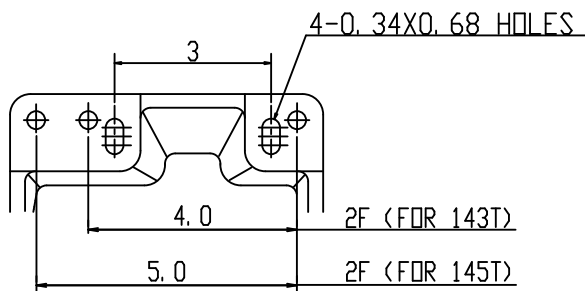
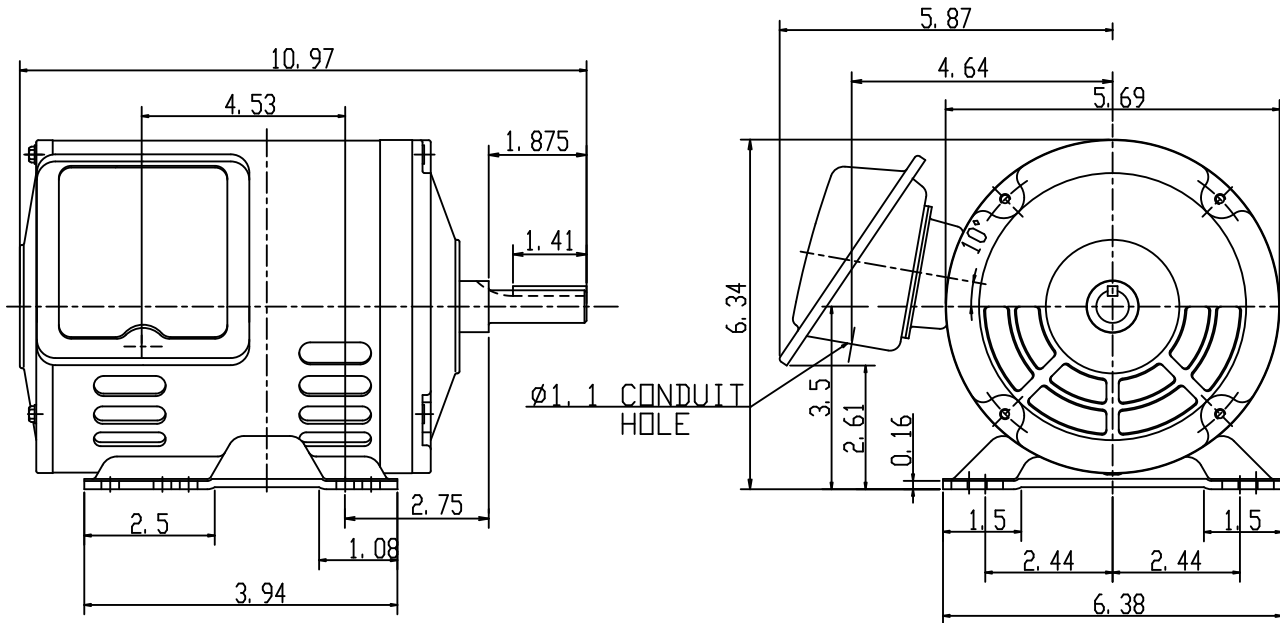

SCALE=3: 1

APPD.	W. H. TSAI	07 21 03
CHKD.	J. B. CHEN	07 20 03
DWN.	Y. Y. CHEN	07 20 03

TEC   Westinghouse

DWG NO.  
31049Z105  
0830

# TECO Westinghouse

ISSUED <b>10/7/2015</b>	<b>PERFORMANCE DATA</b> <b>3-PHASE INDUCTION MOTOR</b>	ENCLOSURE <b>ODP</b>
TYPE <b>ASGHPE</b>		CATALOG# <b>DSP0014</b>

### NAMEPLATE INFORMATION

OUTPUT		POLE	FRAME SIZE	VOLTS	HZ	RATED AMBIENT	INS. CLASS	NEMA DESIGN	TIME RATING	SERVICE FACTOR
HP	KW									
<b>1</b>	<b>0.75</b>	<b>4</b>	<b>56</b>	<b>230/460</b>	<b>60</b>	<b>40°C</b>	<b>F</b>	<b>B</b>	<b>CONT.</b>	<b>1.15</b>

### TYPICAL PERFORMANCE

FULL LOAD RPM	EFFICIENCY				POWER FACTOR			MAXIMUM POWER FACTOR CORRECTION
	FULL LOAD		3/4 LOAD	1/2 LOAD	FULL LOAD	3/4 LOAD	1/2 LOAD	
	MIN%	NOM%						
<b>1750</b>	<b>82.5</b>	<b>85.5</b>	<b>85.0</b>	<b>82.0</b>	<b>75.5</b>	<b>67.0</b>	<b>54.0</b>	<b>0.68 KVAR</b>

### CURRENTS

NO LOAD				FULL LOAD				LOCKED ROTOR				NEMA KVA CODE LETTER
AT	AT	AT	AT	AT	AT	AT	AT	AT	AT	AT	AT	
200 VOLT	208 VOLT	230 VOLT	460 VOLT	200 VOLT	208 VOLT	230 VOLT	460 VOLT	200 VOLT	208 VOLT	230 VOLT	460 VOLT	
<b>1.51</b>	<b>1.64</b>	<b>2.0</b>	<b>1.0</b>	<b>3.34</b>	<b>3.21</b>	<b>2.9</b>	<b>1.5</b>	<b>34.5</b>	<b>33.2</b>	<b>30.0</b>	<b>15.0</b>	<b>N</b>

### TORQUE

### INERTIA

### ACCEL TIME

FULL LOAD	LOCKED ROTOR	PULL UP	BREAK DOWN	ROTOR	NEMA LOAD	MAX ALLOWABLE	NEMA LOAD	MAX ALLOWABLE
lb-ft	%FLT	%FLT	%FLT	WR <sup>2</sup>	WK <sup>2</sup>	WK <sup>2</sup>	WK <sup>2</sup>	WK <sup>2</sup>
				lb-ft <sup>2</sup>	lb-ft <sup>2</sup>	lb-ft <sup>2</sup>	Sec.	Sec.
<b>3.00</b>	<b>365</b>	<b>310</b>	<b>410</b>	<b>0.1</b>	<b>5.8</b>	<b>29.1</b>	<b>3.25</b>	<b>16.09</b>

SAFE STALL TIME IN SECONDS		ALLOWABLE STARTS PER HOUR		SOUND PRESSURE LEVEL @ 3 FT dB(A)
COLD	HOT	COLD	HOT	
<b>46</b>	<b>32</b>	<b>2</b>	<b>1</b>	<b>53</b>

APPROVED:	<b>M. PRATER</b>	DRAWING NO.	<b>31057DSP0014</b>	REV. <b>0</b>
-----------	------------------	-------------	---------------------	---------------

DATE:  
May 28, 2009

# CONNECTION DIAGRAM

CATALOG NO.:  
DSP0014



**SCHEMATIC - 2Y/Y CONNECTION**

## ACROSS THE LINE CONNECTION



**LINE**  
**230 VOLT CONNECTION**



**LINE**  
**460 VOLT CONNECTION**

**TECO**  **Westinghouse**

DWG NO.  
**DAC-1566-2**