

DATE
February 16, 2004

CATALOG NO.
DSP1_52

OUTLINE DIMENSIONS
3-PHASE INDUCTION MOTOR

MODEL TYPE:
ASGHPE

FRAME NO. A56

Pole	HP	KW	Hz	VOLT	Syn. Speed R. P. M
2	1.5	1.11	60	230/460	3600

Ins.	Rating	Dimensions in	Approx Weight	Bearings
F	CONT.	inch	28.0 lbs	DF: 6205ZZ NDE: 6204ZZ

OPEN DRIP-PROOF

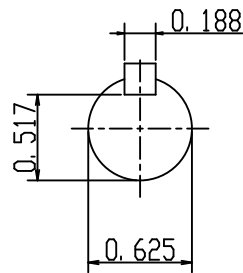
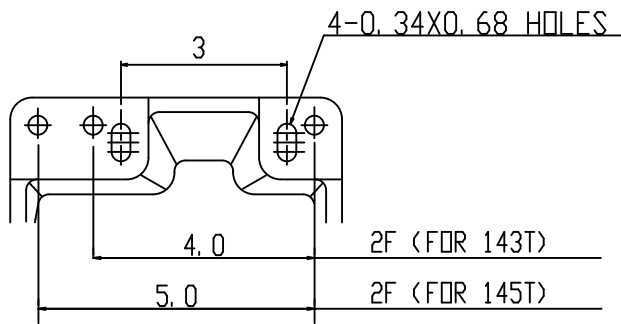
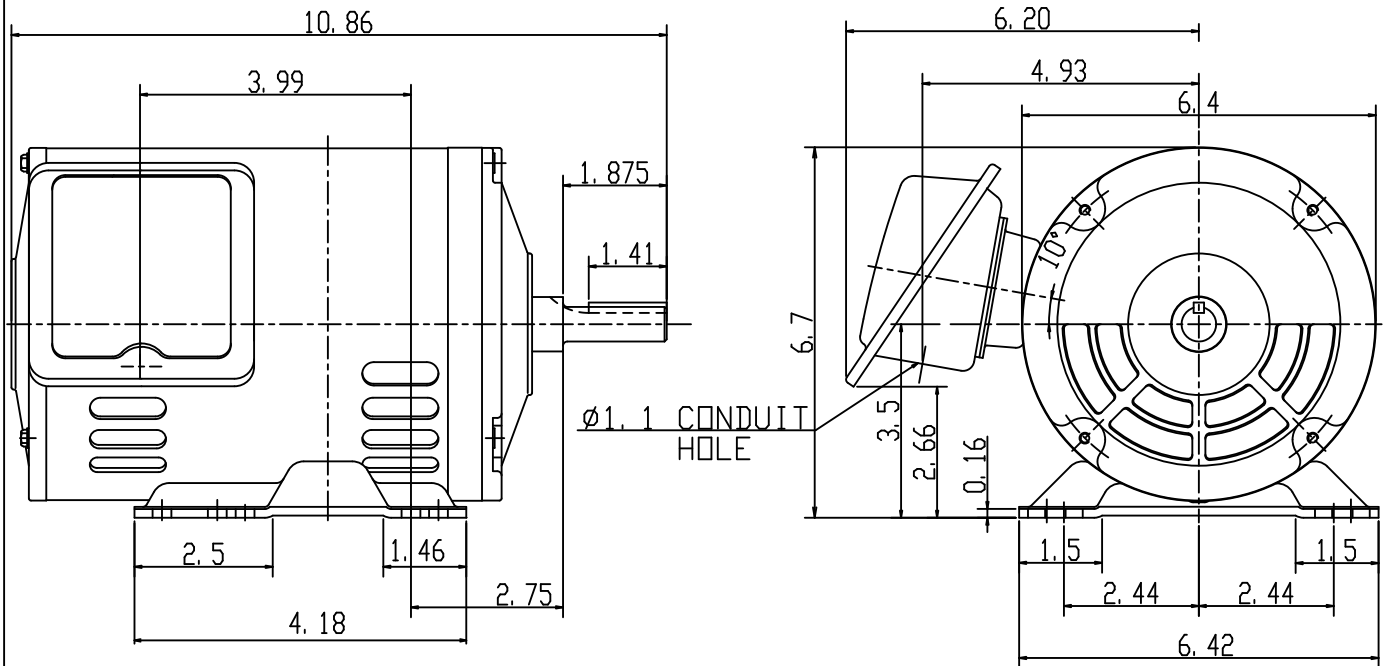

SCALE=3: 1

APPD.	W. H. TSAI	04 03 03
CHKD.	J. B. CHEN	04 03 03
DWN.	P. J. CHEN	04 03 03

TEC   Westinghouse

DWG NO.
31049Z105
0873

TECO Westinghouse

ISSUED 10/7/2015	PERFORMANCE DATA 3-PHASE INDUCTION MOTOR	ENCLOSURE ODP
TYPE ASGHPE		CATALOG# DSP1/52

NAMEPLATE INFORMATION

OUTPUT		POLE	FRAME SIZE	VOLTS	HZ	RATED AMBIENT	INS. CLASS	NEMA DESIGN	TIME RATING	SERVICE FACTOR
HP	KW									
1.5	1.12	2	56	230/460	60	40°C	F	B	CONT.	1.15

TYPICAL PERFORMANCE

FULL LOAD RPM	EFFICIENCY				POWER FACTOR			MAXIMUM POWER FACTOR CORRECTION
	FULL LOAD		3/4 LOAD	1/2 LOAD	FULL LOAD	3/4 LOAD	1/2 LOAD	
	MIN%	NOM%						
3510	82.5	85.5	85.5	83.0	83.0	76.5	64.0	0.95 KVAR

CURRENTS

NO LOAD				FULL LOAD				LOCKED ROTOR				NEMA KVA CODE LETTER
AT 200 VOLT	AT 208 VOLT	AT 230 VOLT	AT 460 VOLT	AT 200 VOLT	AT 208 VOLT	AT 230 VOLT	AT 460 VOLT	AT 200 VOLT	AT 208 VOLT	AT 230 VOLT	AT 460 VOLT	
2.12	2.29	2.8	1.4	4.55	4.38	4.0	2.0	46.0	44.2	40.0	20.0	

TORQUE

INERTIA

ACCEL TIME

FULL LOAD lb-ft	LOCKED ROTOR %FLT	PULL UP %FLT	BREAK DOWN %FLT	ROTOR WR ² lb-ft ²	NEMA LOAD WK ² lb-ft ²	MAX ALLOWABLE WK ² lb-ft ²	NEMA LOAD WK ² Sec.	MAX ALLOWABLE WK ² Sec.
2.24	400	310	450	0.059	1.8	5.8	2.52	7.92

SAFE STALL TIME IN SECONDS		ALLOWABLE STARTS PER HOUR		SOUND PRESSURE LEVEL @ 3 FT dB(A)
COLD	HOT	COLD	HOT	
17	12	2	1	58

APPROVED:	M. PRATER	DRAWING NO.	31057DSP1/52	REV. 0
-----------	------------------	-------------	---------------------	---------------

DATE:
May 28, 2009

CONNECTION DIAGRAM

CATALOG NO.:
DSP1/52

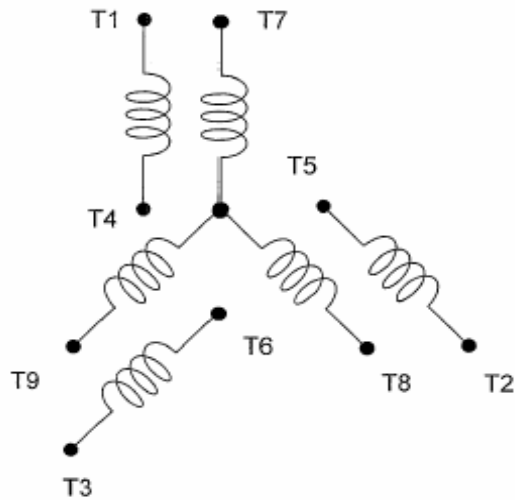

SCHEMATIC - 2Y/Y CONNECTION

ACROSS THE LINE CONNECTION



LINE
230 VOLT CONNECTION

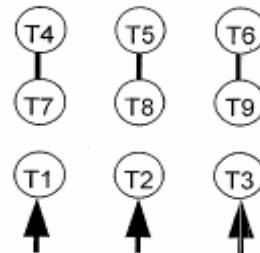

LINE
460 VOLT CONNECTION

TECO  **Westinghouse**

DWG NO.
DAC-1566-2