

DATE  
MAY 28, 2009  
CATALOG # DTP0014G

OUTLINE DIMENSIONS  
3-PHASE INDUCTION MOTOR

MOTOR TYPE:  
ASGH-SGR  
FRAME NO. 143T

Pole	HP	kW	Hz	VOLT	r/min
4	1	0.75	60	230/460	1800

Ins	Rating	Dimension in	Approx Weight	Bearings
F	CONT.	inch.	35 lbs.	DE: 6205ZZ NDE: 6204ZZ

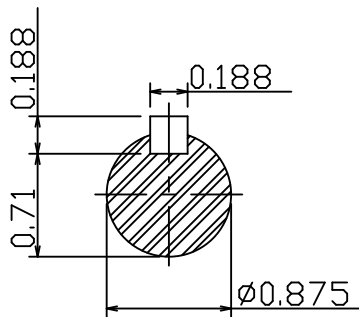
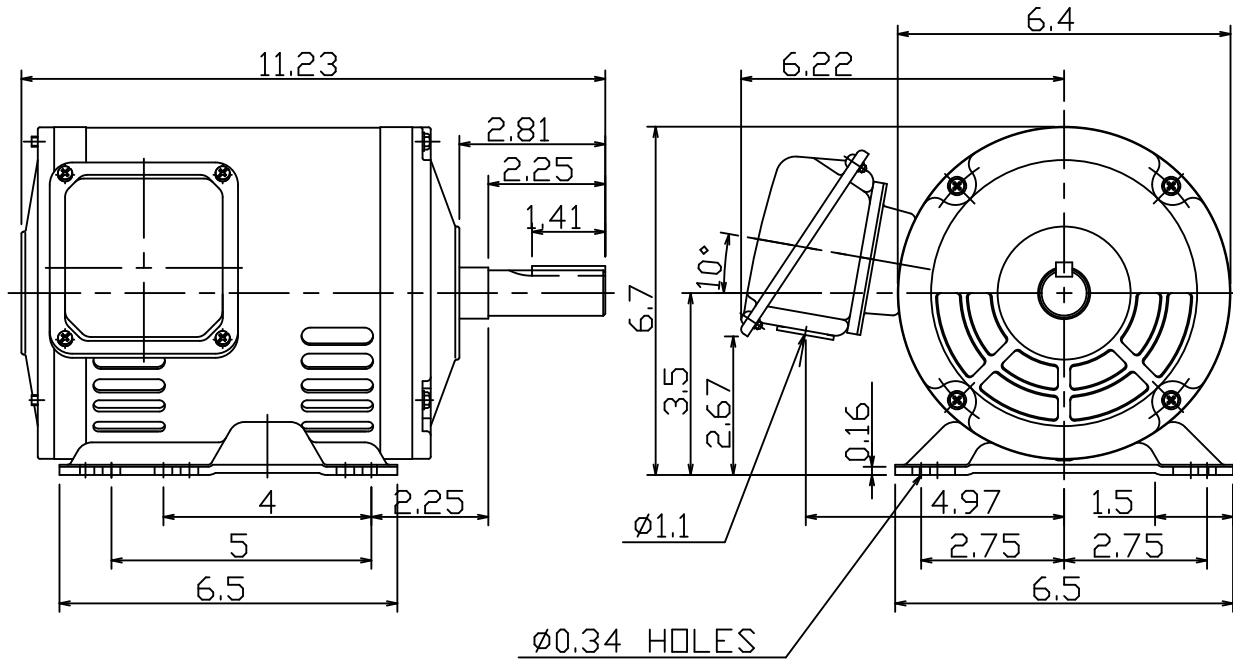

NOTE:  
1.AEGIS Grounding ring installed on Drive-end.



DWN.	陳奕元	01 12 09
CHKD.	陳敬元	01 16 09
APPD.	蔡明 <sup>o</sup>	01 16 09

東元電機股份有限公司  
TECO Electric & Machinery Co., Ltd.  
TAIWAN

DWG NO.  
31049Z107360

# TECO Westinghouse

ISSUED <b>8/18/2015</b>	<b>PERFORMANCE DATA</b>	ENCLOSURE <b>ODP</b>
TYPE <b>ASGH-SGR</b>	<b>3-PHASE INDUCTION MOTOR</b>	CATALOG# <b>DTP0014G</b>

### NAMEPLATE INFORMATION

OUTPUT		POLE	FRAME SIZE	VOLTS	HZ	RATED AMBIENT	INS. CLASS	NEMA DESIGN	TIME RATING	SERVICE FACTOR
HP	KW									
<b>1</b>	<b>0.75</b>	<b>4</b>	<b>143T</b>	<b>230/460</b>	<b>60</b>	<b>40°C</b>	<b>F</b>	<b>B</b>	<b>CONT.</b>	<b>1.15</b>

### TYPICAL PERFORMANCE

FULL LOAD RPM	EFFICIENCY				POWER FACTOR			MAXIMUM POWER FACTOR CORRECTION
	FULL LOAD		3/4 LOAD	1/2 LOAD	FULL LOAD	3/4 LOAD	1/2 LOAD	
	MIN%	NOM%	%	%	%	%	%	
<b>1750</b>	<b>82.5</b>	<b>85.5</b>	<b>85.0</b>	<b>82.0</b>	<b>75.5</b>	<b>67.0</b>	<b>54.0</b>	<b>0.61 KVAR</b>

### CURRENTS

NO LOAD				FULL LOAD				LOCKED ROTOR				NEMA KVA CODE LETTER
AT 200 VOLT	AT 208 VOLT	AT 230 VOLT	AT 460 VOLT	AT 200 VOLT	AT 208 VOLT	AT 230 VOLT	AT 460 VOLT	AT 200 VOLT	AT 208 VOLT	AT 230 VOLT	AT 460 VOLT	
<b>1.36</b>	<b>1.47</b>	<b>1.80</b>	<b>0.90</b>	<b>3.34</b>	<b>3.21</b>	<b>2.90</b>	<b>1.45</b>	<b>26.1</b>	<b>27.1</b>	<b>30.0</b>	<b>15.0</b>	

### TORQUE

### INERTIA

### ACCEL TIME

FULL LOAD lb-ft	LOCKED ROTOR %FLT	PULL UP %FLT	BREAK DOWN %FLT	ROTOR WR <sup>2</sup> lb-ft <sup>2</sup>	NEMA LOAD WK <sup>2</sup> lb-ft <sup>2</sup>	MAX ALLOWABLE WK <sup>2</sup> lb-ft <sup>2</sup>	NEMA LOAD WK <sup>2</sup> Sec.	MAX ALLOWABLE WK <sup>2</sup> Sec.
<b>3.00</b>	<b>365</b>	<b>310</b>	<b>410</b>	<b>0.1</b>	<b>5.8</b>	<b>17.4</b>	<b>3.25</b>	<b>9.65</b>

SAFE STALL TIME IN SECONDS		ALLOWABLE STARTS PER HOUR		SOUND PRESSURE LEVEL @ 3 FT dB(A)
COLD	HOT	COLD	HOT	
<b>44</b>	<b>31</b>	<b>2</b>	<b>1</b>	<b>52</b>

APPROVED:	<b>M. PRATER</b>	DRAWING NO.	<b>31057DTP0014G</b>	REV. <b>0</b>
-----------	------------------	-------------	----------------------	---------------

DATE:  
May 28, 2009

# CONNECTION DIAGRAM

CATALOG NO.:  
DTP0014G



**SCHEMATIC - 2Y/Y CONNECTION**

## ACROSS THE LINE CONNECTION

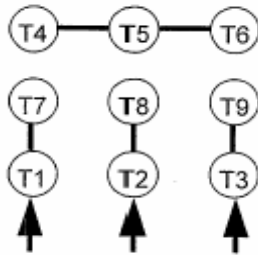

**LINE**  
**230 VOLT CONNECTION**

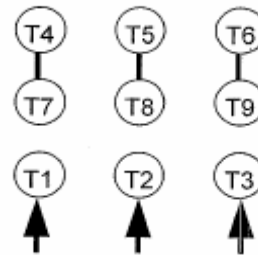

**LINE**  
**460 VOLT CONNECTION**

**TECO**  **Westinghouse**

DWG NO.  
**DAC-1566-2**