

DATE
MAY 28, 2009
CATALOG # DTP1/52

OUTLINE DIMENSIONS
3-PHASE INDUCTION MOTOR

MOTOR TYPE:
ASGH
FRAME NO. 143T

Pole	HP	kW	Hz	VOLT	r/min
2	1.5	1.12	60	230/460	3600

Ins	Rating	Dimension in	Approx Weight	Bearings
F	CONT.	inch.	28 lbs.	DE: 6205ZZ NDE: 6204ZZ

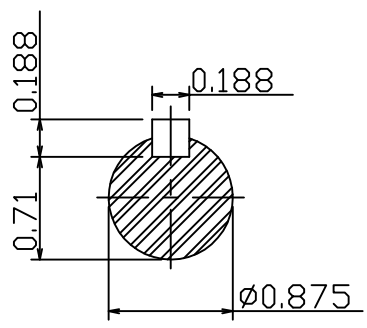
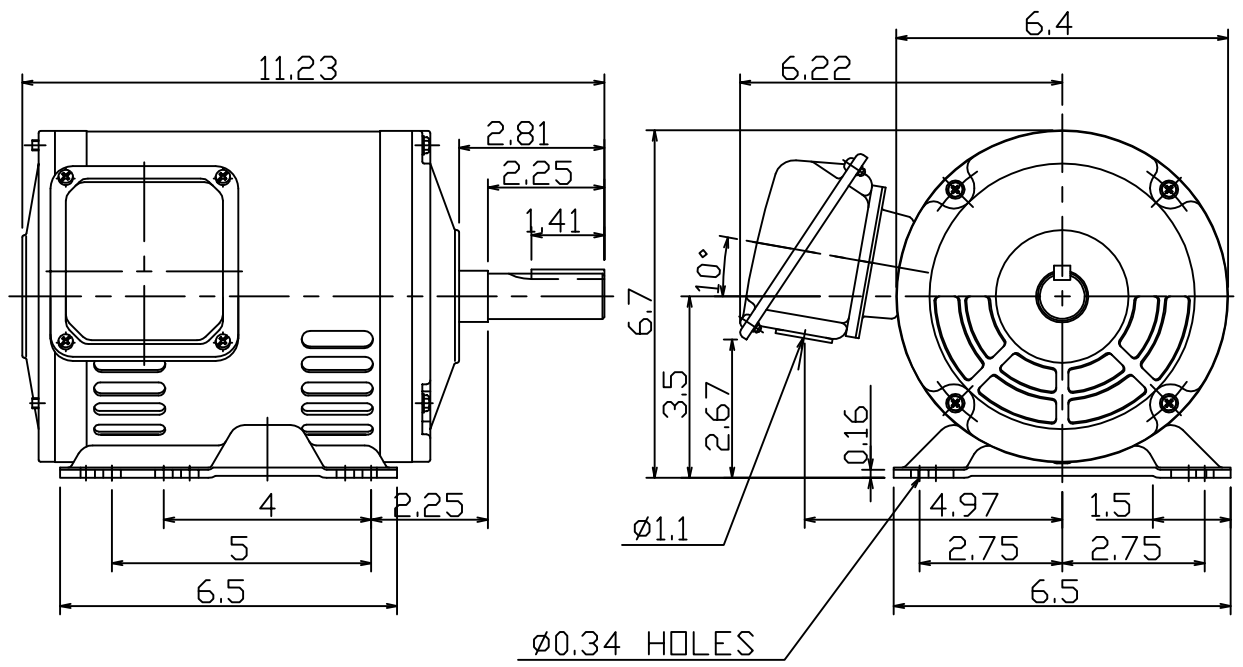

DWN.	陳奕元	01 12 09
CHKD.	陳敬元	01 16 09
APPD.	蔡明釗	01 16 09

東元電機股份有限公司
TECO Electric & Machinery Co., Ltd.
TAIWAN

DWG NO.
31049Z107360

TECO Westinghouse

ISSUED 4/7/2015	PERFORMANCE DATA	ENCLOSURE ODP
TYPE ASGH	3-PHASE INDUCTION MOTOR	CATALOG# DTP1/52

NAMEPLATE INFORMATION

OUTPUT		POLE	FRAME SIZE	VOLTS	HZ	RATED AMBIENT	INS. CLASS	NEMA DESIGN	TIME RATING	SERVICE FACTOR
HP	KW									
1.5	1.12	2	143T	230/460	60	40°C	F	B	CONT.	1.15

TYPICAL PERFORMANCE

FULL LOAD RPM	EFFICIENCY				POWER FACTOR			MAXIMUM POWER FACTOR CORRECTION
	FULL LOAD		3/4 LOAD	1/2 LOAD	FULL LOAD	3/4 LOAD	1/2 LOAD	
	MIN%	NOM%	%	%	%	%	%	
3510	81.5	85.5	85.5	83.0	83.0	76.5	64.0	0.61 KVAR

CURRENTS

NO LOAD				FULL LOAD				LOCKED ROTOR				NEMA KVA CODE LETTER
AT 200 VOLT	AT 208 VOLT	AT 230 VOLT	AT 460 VOLT	AT 200 VOLT	AT 208 VOLT	AT 230 VOLT	AT 460 VOLT	AT 200 VOLT	AT 208 VOLT	AT 230 VOLT	AT 460 VOLT	
1.44	1.55	1.90	0.95	4.55	4.38	3.96	1.98	34.8	36.2	40.0	20.0	

TORQUE

INERTIA

ACCEL TIME

FULL LOAD lb-ft	LOCKED ROTOR %FLT	PULL UP %FLT	BREAK DOWN %FLT	ROTOR WR ² lb-ft ²	NEMA LOAD WK ² lb-ft ²	MAX ALLOWABLE WK ² lb-ft ²	NEMA LOAD WK ² Sec.	MAX ALLOWABLE WK ² Sec.
2.24	400	310	450	0.059	1.8	4.6	2.52	6.32

SAFE STALL TIME IN SECONDS		ALLOWABLE STARTS PER HOUR		SOUND PRESSURE LEVEL @ 3 FT dB(A)
COLD	HOT	COLD	HOT	
18	13	2	1	60

APPROVED:	M. PRATER	DRAWING NO.	31057DTP1/52	REV. 0
-----------	------------------	-------------	---------------------	---------------

DATE:
May 28, 2009

CONNECTION DIAGRAM

CATALOG NO.:
DTP1/52



SCHEMATIC - 2Y/Y CONNECTION

ACROSS THE LINE CONNECTION



LINE
230 VOLT CONNECTION



LINE
460 VOLT CONNECTION

TECO  **Westinghouse**

DWG NO.
DAC-1566-2