

PRODUCT INFORMATION PACKET

Model No: 256TTFC6540

Catalog No: E045

XRI®-SD Severe Duty Motor, 20 HP, 3 Ph, 60 Hz, 230/460 V, 1800 RPM, 256TC Frame, TEFC



Regal and Marathon are trademarks of Regal Rexnord Corporation or one of its affiliated companies.

©2022 Regal Rexnord Corporation, All Rights Reserved. MC017097E



Nameplate Specifications

Output HP	20 Hp	Output KW	14.9 kW
Frequency	60 Hz	Voltage	230/460 V
Current	48.5/24.2 A	Speed	1768 rpm
Service Factor	1.15	Phase	3
Efficiency	93 %	Power Factor	83.5
Duty	Continuous	Insulation Class	H
Design Code	B	KVA Code	G
Frame	256TC	Enclosure	Totally Enclosed Fan Cooled
Thermal Protection	No Protection	Ambient Temperature	40 °C
Drive End Bearing Size	6309	Opp Drive End Bearing Size	6209
UL	Listed	CSA	Y
CE	Y	IP Code	55
Hazardous Location	DIVISION 2 T2B	Number of Speeds	1

Technical Specifications

Electrical Type	Squirrel Cage Inverter Rated	Starting Method	Line Or Inverter
Poles	4	Rotation	Reversible
Resistance Main	.513 Ohms	Mounting	Rigid Base
Motor Orientation	Horizontal	Drive End Bearing	Ball
Opp Drive End Bearing	Ball	Frame Material	Cast Iron
Shaft Type	T	Shaft Diameter	1.626 in
Assembly/Box Mounting	F1/F2 CAPABLE	Inverter Load	CONSTANT 10:1/VARIABLE 10:1
Connection Drawing	EE7308	Outline Drawing	SS208571-200

This is an uncontrolled document once printed or downloaded and is subject to change without notice. Date Created:11/29/2022

DASH NO.	4		3					2		1		
	B	C	E	2E	2F	2FF	AG	AH	BA	BV	MOUNTING	FRAME
100	9.60	24.65	5.00	10.00	---	8.25	20.90	3.75	4.75	9.14	F1 OR F2	254TC
200	11.34	26.39			8.25	10.00	22.64			10.00		254/256TC

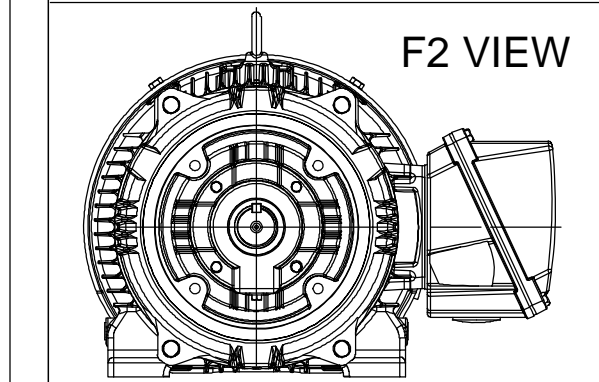
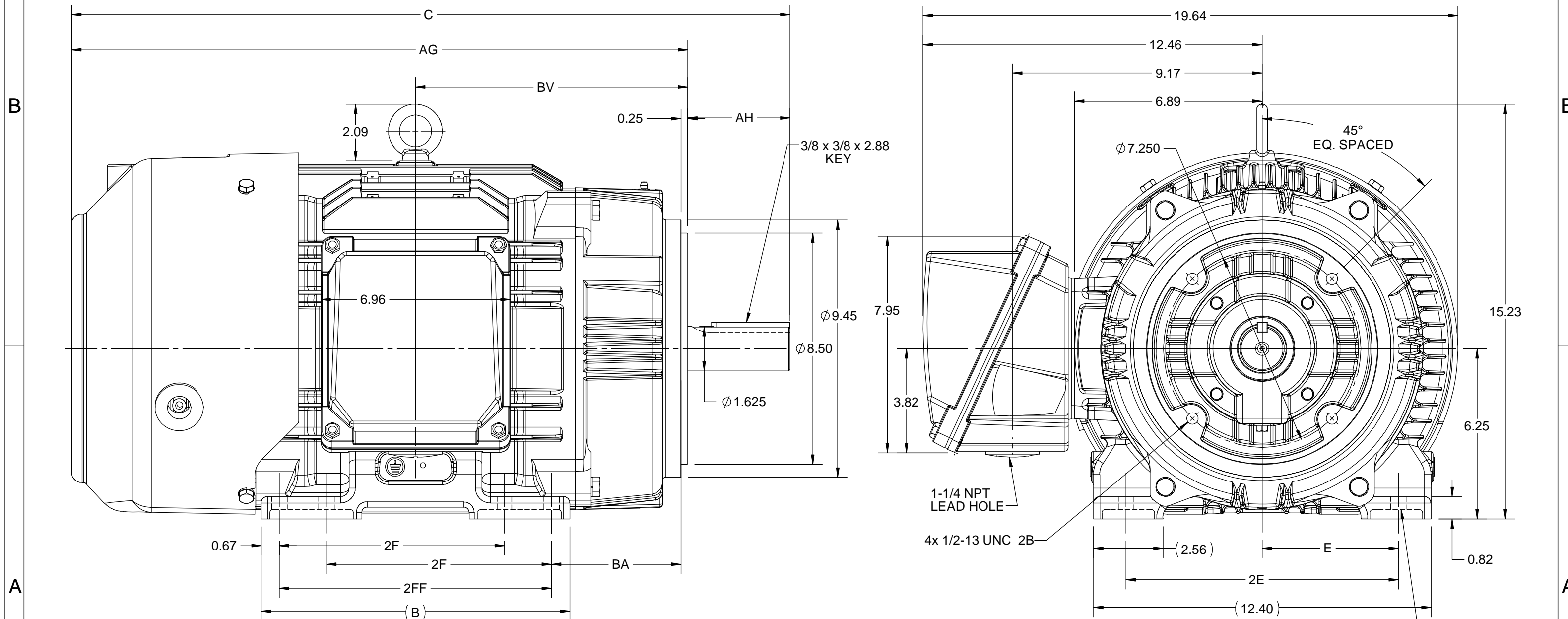

DRAWING REVISION B	REVISION BY BISWA	REV DATE/© DATE 2109/2020
ECO ECO-0192056	APPROVED BY SBD	DATE 2109/2020
ECO DESCRIPTION		
DRAWING UPDATED		
<small>COPYRIGHT (PER REVISION DATE) REGAL BELOIT AMERICA, INC. ALL RIGHTS RESERVED. PROPRIETARY AND CONFIDENTIAL INFORMATION - THIS DOCUMENT IS THE PROPERTY OF REGAL BELOIT AMERICA, INC. ("OWNER") AND CONTAINS OWNER'S PROPRIETARY INFORMATION. ANY PERSON, CORPORATION OR OTHER FIRM RECEIVING IT IS DEEMED, BY RECEIVING IT, TO AGREE THAT IT, AND/OR ANY PART OF IT, SHALL NOT BE DISCLOSED TO ANY PERSON, CORPORATION OR OTHER ENTITY, DUPLICATED, AND/OR USED, EXCEPT AS EXPRESSLY APPROVED IN WRITING IN ADVANCE BY OWNER. THIS DOCUMENT SHALL BE RETURNED TO OWNER UPON REQUEST. IT MAY BE SUBJECT TO CERTAIN RESTRICTIONS UNDER APPLICABLE EXPORT CONTROL LAWS AND REGULATIONS.</small>		

PRIMARY DIMENSIONS ARE INCH
mm DIMENSIONS IN [BRACKETS]
ARE FOR REFERENCE ONLY

DRAWN BY BISWA	Regal Beloit America, Inc.
DATE 13/03/2019	
APPROVED BY SBD	DESCRIPTION
DATE 13/03/2019	OUTLINE 254/256TC FR-NEMA-SD & IEEE841
REFERENCE	MATERIAL
THIRD ANGLE PROJECTION	SIZE B
	DRAWING NUMBER SS208571
	SHEET 1 OF 1

EE7308

THREE PHASE
DUAL VOLTAGE MOTOR



VIEW OF TERMINAL END

REF.
WINDING DIAGRAM

T8Y, T2Y, T2BL, T4BX, T2EC, T2G
T6BZ, T2B, T6BL, T4AV, T6B, T4B

OPTIONAL CORD
CONNECTION

L1 — WHITE
L2 — RED
L3 — BLACK

NO.	REVISION	BY & DATE	CHK	ANG	TOLERANCES UNLESS SPECIFIED		FINISH	DRAWN RM 11/20/1990				
					DEC.	INCHES						
5	CHG TO REGAL LOGO	SL 09/10/2015	AB					CHK ML 11/21/1990				
4	REVISED IEC NOTATIONS	MSG 11/15/2011	CMN	.X	±.1			APPD SAS 04/24/2003				
3	ADDED IEC NOTATIONS... (U1), (V1) ETC. MU95194	MSG 5/10/2010	MJS	.XX	±.02			SCALE 1=1				
2	ADDED THE OPTIONAL CORD CONNECTION MU46318	RDH 04/24/2003	DRS	.XXX	±.005		TITLE CONNECTION DIAGRAM 3Ø - DUAL VOLTAGE MOTOR	REF				
1	REDRAWN	RM 11/20/1990		.XXXX	±.0005		MAT'L.	FMF				
					±7'30"			PREV				
THIS DRAWING IN DESIGN AND DETAIL IS OUR PROPERTY AND MUST NOT BE USED EXCEPT IN CONNECTION WITH OUR WORK ALL RIGHTS OF DESIGN AND INVENTION ARE RESERVED THIS IS AN ELECTRONICALLY GENERATED DOCUMENT - DO NOT SCALE THIS PRINT							RFP	CAD FILE ee7308	SIZE A	DRAWING NO. EE7308	PAGE OF 5	REV. 5
							DIST WP					

