

PRODUCT INFORMATION PACKET

Model No: 215TTDWD16349

Catalog No: E178A

Close-Coupled Pump Motor, 10 HP, 3 Ph, 60 Hz, 230/460 V, 1800 RPM, 215JMV Frame, DP



Regal and are trademarks of Regal Rexnord Corporation or one of its affiliated companies.
©2022 Regal Rexnord Corporation, All Rights Reserved. MC017097E

Nameplate Specifications

Output HP	10 Hp	Output KW	7.5 kW
Frequency	60 Hz	Voltage	230/460 V
Current	26.2/13.1 A	Speed	1765 rpm
Service Factor	1.15	Phase	3
Efficiency	91.7 %	Power Factor	77.8
Duty	Continuous	Insulation Class	B
Design Code	B	KVA Code	H
Frame	215JMV	Enclosure	Drip Proof
Thermal Protection	No Protection	Ambient Temperature	40 °C
Drive End Bearing Size	6309	Opp Drive End Bearing Size	6206
UL	Recognized	CSA	Y
CE	Y	IP Code	12
Number of Speeds	1		

Technical Specifications

Electrical Type	Squirrel Cage Induction Run	Starting Method	Across The Line
Poles	4	Rotation	Reversible
Resistance Main	1.022 Ohms	Mounting	Round
Motor Orientation	Shaft Down	Drive End Bearing	Ball
Opp Drive End Bearing	Ball	Frame Material	Rolled Steel
Shaft Type	JM	Overall Length	20.44 in
Frame Length	11.15 in	Shaft Diameter	0.875 in
Shaft Extension	4.25 in	Assembly/Box Mounting	F1/F2 CAPABLE
Outline Drawing	SS86596-1115	Connection Drawing	00501001ME

SS86596

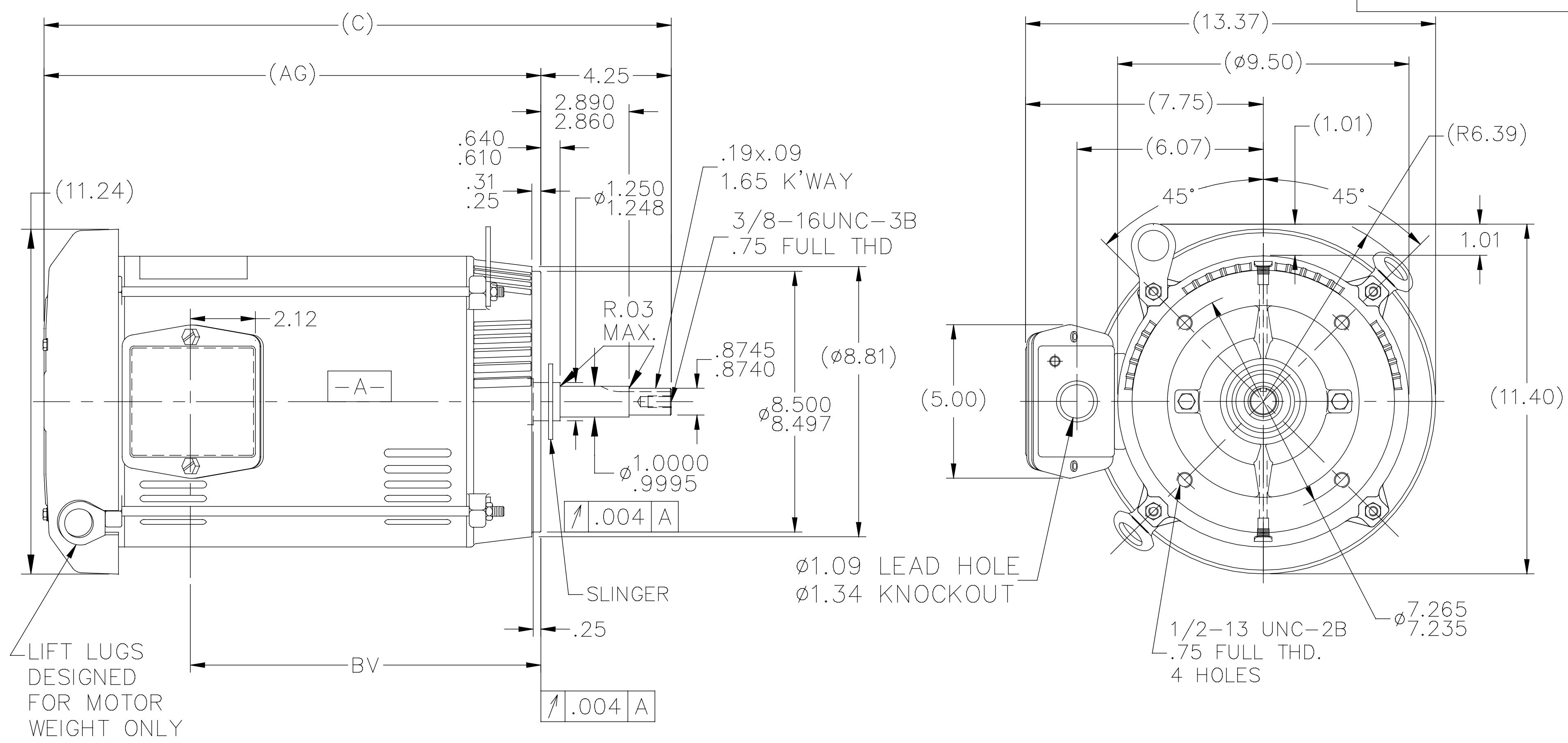

DASH	FR.	C	AG	BV
965	213JM	18.94	14.69	9.93
1115	213/15JM	20.44	16.19	11.43
1240	213/15JM	21.69	17.44	12.68

NOTES:

1. NAMEPLATE TO BE READ FROM SHAFT EXT. END OF MOTOR.
2. BOX CAN BE MOUNTED IN 90° STEPS.

NO.	REVISION	BY & DATE	CHK	ANG	±7'30"
6	TITLE BLOCK LOGO CHANGE PER ECO-0078542	MDV 06/09/2015			
5	UPDATED DRAWING	TJW 04/30/2007			
4	REDRAWN IN AUTOCAD	TAT 07-06-2004	ML	.X	±.1
3	UPDATED DRIP COVER GEOMETRY CN 29200-433	DRS 01-25-2002		.XX	±.03
2	UPDATED C' BOX GEOMETRY CN 28425	DRS 01-31-2001		.XXX	±.005
1	NEW DRAWING - DES/DEV	DA 04-02-1996		.XXXX	±.0005

TOLERANCES UNLESS SPECIFIED

DEC. INCHES



Regal Beloit America, Inc.

TITLE OUTLINE - C' FACE
210JM FR. - DR. PR.

MAT'L.

FINISH

DRAWN	DA 03 26 1996
CHK	ML 04-01-1996
APPD	DN 04-01-1996
SCALE	1=5
REF	
FMF	
PREV	

THIS DRAWING IN DESIGN AND DETAIL IS OUR PROPERTY AND MUST NOT BE USED EXCEPT IN CONNECTION WITH OUR WORK ALL RIGHTS OF DESIGN AND INVENTION ARE RESERVED THIS IS AN ELECTRONICALLY GENERATED DOCUMENT - DO NOT SCALE THIS PRINT

RFP
DIST LB

CAD FILE ss86596

SIZE	DRAWING NO.	PAGE	OF	REV.
A	SS86596			6

VIEW FROM OUTSIDE OF MOTOR AT SWITCH END.



VOLTAGE	L1	L2	L3	JOIN & INSULATE
HIGH	T1	T2	T3	(T4,T7) (T5,T8) (T6,T9)
LOW	T1,T7	T2,T8	T3,T9	T4,T5,T6

		TOLERANCES UNLESS SPECIFIED		DRAWN RDW 04/12/02					
		DEC.	INCHES	CHK					
		.X	±.1	APPD					
		.XX	±.01	SCALE 1=1					
		.XXX	±.005	REF FIG.2-51					
		.XXXX	±.0005	FMF					
NO.	REVISION	BY & DATE	CHK	ANG	±1/2'	FINISH	SIZE	DRAWING NO.	REV.
			RFP	04/12/02		CAD FILE	A	005010-01ME	
			DIST						

THIS DRAWING IN DESIGN AND DETAIL IS OUR PROPERTY AND MUST NOT BE USED EXCEPT IN CONNECTION WITH OUR WORK ALL RIGHTS OF DESIGN AND INVENTION ARE RESERVED THIS IS AN ELECTRONICALLY GENERATED DOCUMENT - DO NOT SCALE THIS PRINT



TITLE EXTERNAL WIRING DIAGRAM
3 PHASE W/O PROTECTOR
MAT'L. DECAL - 004014

Data Sheet

Date: 20-06-2017
 Customer: _____
 Attention: _____
 Submitted by: FAREEDA DUDEKULA



215TTDWD16349

Submittal

Data @ 460 V

Motor Load Data

Load	0%	25%	50%	75%	100%	115%	125%	LR
Current (Amps)	6.6	7.0	8.5	10.6	13.1	14.8	15.9	80.5
Torque (ft-lb)	0.00	7.5	14.7	22.2	29.7	34.4	37.4	62.3
RPM	1800	1790	1784	1775	1765	1,758	1755	0
Efficiency (%)		90.8	91.4	92.1	91.7	90.8	90.5	
P.F. (%)	4.7	37.7	60.2	72.0	77.8	80.2	81.3	42.0

Motor Speed Data

	LR	Pull-Up	BD	Rated	Idle
Speed (RPM)	0	900	1575	1765	1800
Current (Amps)	80.5	79.0	49.0	13.1	6.6
Torque (ft-lb)	62.3	58.0	83.3	29.7	0.00

Information Block				
HP	10.0			
Sync. RPM	1800			
Frame	215			
Enclosure	DP			
Construction	TDW			
Voltage	230/460#190/38(V)			
Frequency	60 Hz			
Design	B			
LR Code letter	H			
Service Factor	1.15			
Temp Rise @ FL	25 ° C			
Duty	CONT			
Ambient	40 ° C			
Elevation	1,000 feet			
Rotor/Shaft wk ²	1.00 Lb-Ft ²			
Ref Wdg	K2154505 NONE			
Sound Pressure @ 1M	60 dBA			
VFD Rating	NONE			
Outline Dwg	SS86596-1115			
Conn. Diag	005010.01			
Additional Specifications:				
0				
365THFS8036				
EQUIV CKT (OHMS / PHASE)				
R1	R2	X1	X2	Xm
0.6240	0.4420	2.0540	2.3490	39.0020

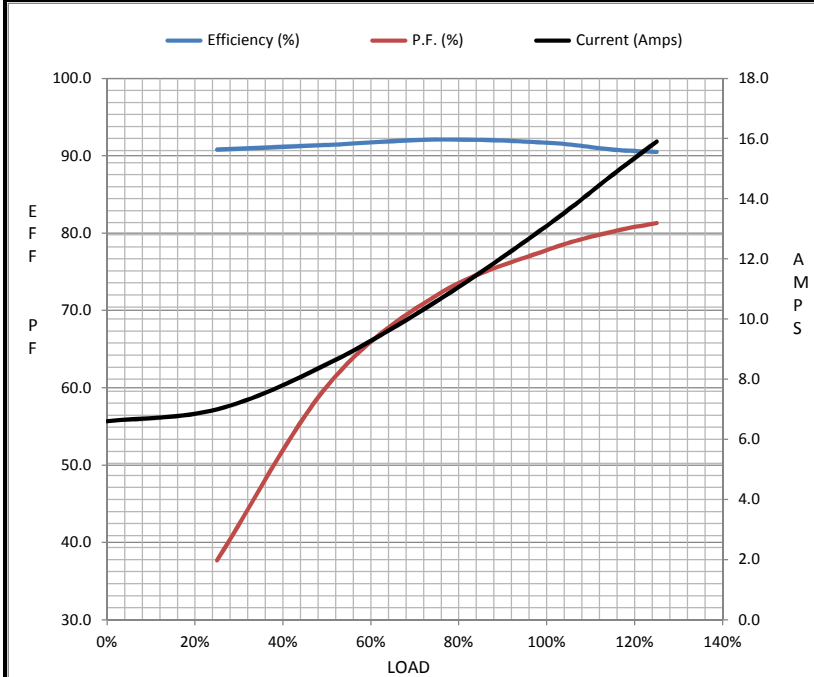

Speed - Torque Curve

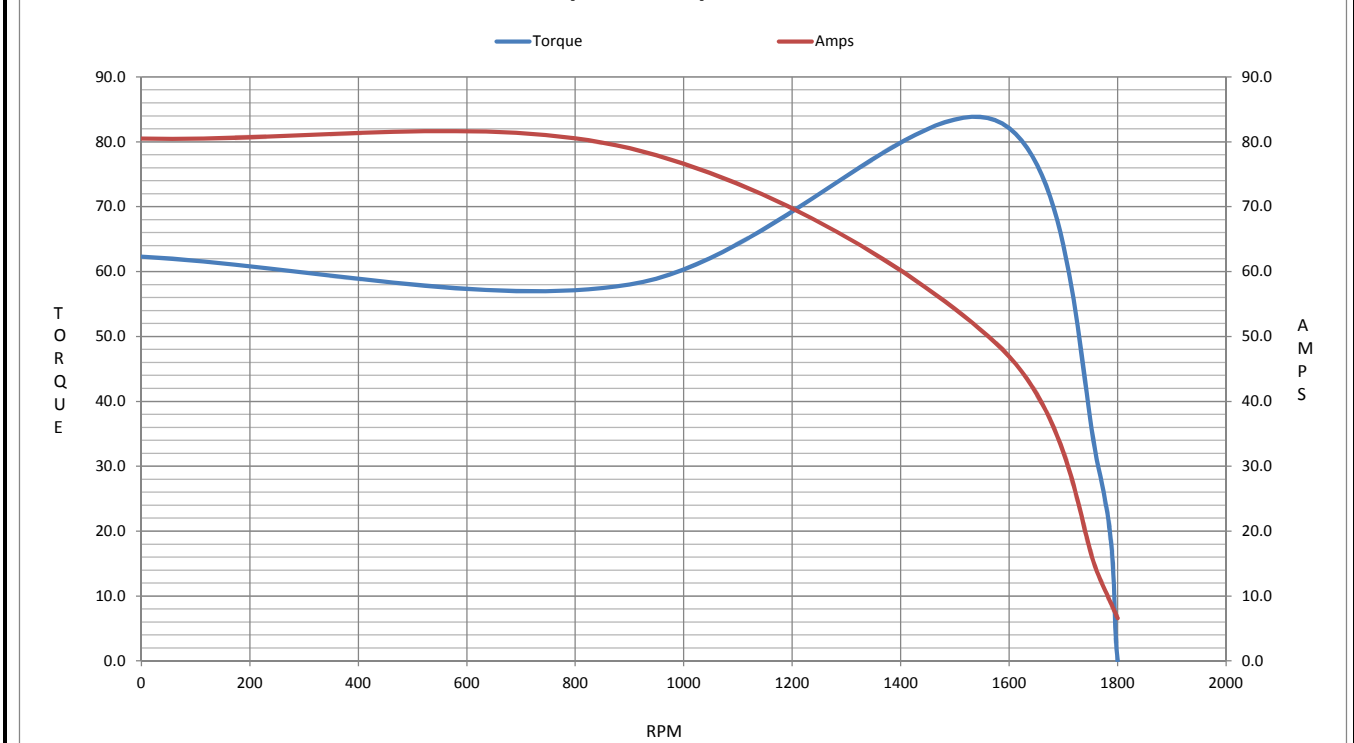

EC Declaration of Conformity

The undersigned representing
the manufacturer:

Regal Beloit America
100 East Randolph St.
Wausau, WI 54401

and the authorized representative
established within the Community:

Marathon Electric UK
6F Thistleton Road Ind. Estate
Market Overton
Oakham, Rutland LE15 7PP UK

are committed to providing customers with products that comply with applicable regulations and international protocols to which they are subject, including the requirements of the European Parliament Directive on the Harmonization of the laws relating to electrical equipment designed for use within certain voltage limits (2014/35/EU).

Regal Beloit America declares that the following product(s), to which this declaration relates, are in conformity with the relevant sections of the EC standards listed below.

This statement supersedes any statements previously issued pertaining to the product(s) listed below and is subject to change without notice.

Model No : 215TTDWD16349

(Model No. may contain prefix and/or suffix characters)

Catalog No : E178A

Rework No : N/A

Directives :

Low Voltage Directive 2014/35/EU

Harmonized Standards Used :

EN 60034-1: 2010 (IEC 60034-1: 2010)

EN 60034-5: 2001/A1:2007 (IEC 60034-5: 2000/A1:2006)

Authorized Representative:



Michael A. Logsdon
Vice President, Technology

Authorized Representative in the Community:



Julian Clark
Marketing Engineer

Created on 09/01/2022

CE 22