

PRODUCT INFORMATION PACKET

marathon®
Motors

Model No: 215TTFC6881

Catalog No: E474B

XRI®-SD Severe Duty Motor, 5 HP, 3 Ph, 60 Hz, 230/460 V, 1200 RPM, 215T Frame, TEFC



Regal and Marathon are trademarks of Regal Rexnord Corporation or one of its affiliated companies.
©2022 Regal Rexnord Corporation, All Rights Reserved. MC017097E

RegalRexnord



Nameplate Specifications

Output HP	5 Hp	Output KW	3.7 kW
Frequency	60 Hz	Voltage	230/460 V
Current	13.6/6.8 A	Speed	1180 rpm
Service Factor	1.15	Phase	3
Efficiency	89.5 %	Power Factor	77.5
Duty	Continuous	Insulation Class	H
Design Code	B	KVA Code	J
Frame	215T	Enclosure	Totally Enclosed Fan Cooled
Thermal Protection	No Protection	Ambient Temperature	40 °C
Drive End Bearing Size	6308	Opp Drive End Bearing Size	6208
UL	Listed	CSA	Y
CE	Y	IP Code	55
Hazardous Location	DIVISION 2 T2B	Number of Speeds	1

Technical Specifications

Electrical Type	Squirrel Cage Inverter Rated	Starting Method	Line Or Inverter
Poles	6	Rotation	Reversible
Resistance Main	2.656 Ohms	Mounting	Rigid Base
Motor Orientation	Horizontal	Drive End Bearing	Ball
Opp Drive End Bearing	Ball	Frame Material	Cast Iron
Shaft Type	T	Shaft Diameter	1.375 in
Assembly/Box Mounting	F1/F2 CAPABLE	Inverter Load	CONSTANT 20:1
Connection Drawing	EE7308	Outline Drawing	SS810116-200

This is an uncontrolled document once printed or downloaded and is subject to change without notice. Date Created:11/29/2022

DASH NO.	4				3				MOUNTING	FRAME
	B	C	E	2E	2F	2FF	BA	BS		
100	6.76	18.53	4.25	8.50	---	5.50	3.50	2.75	F1 OR F2	213T
200	8.26	20.03			5.50	7.00		3.50		213/215T

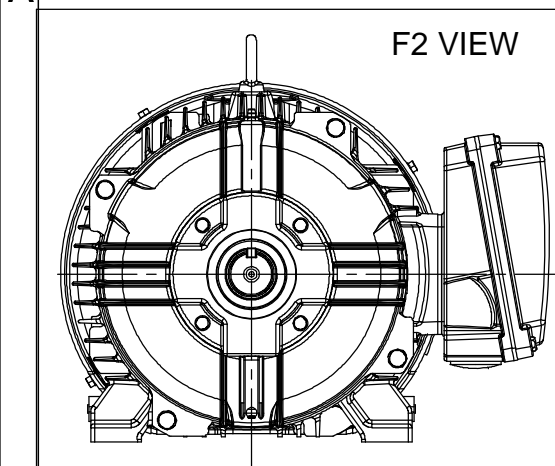
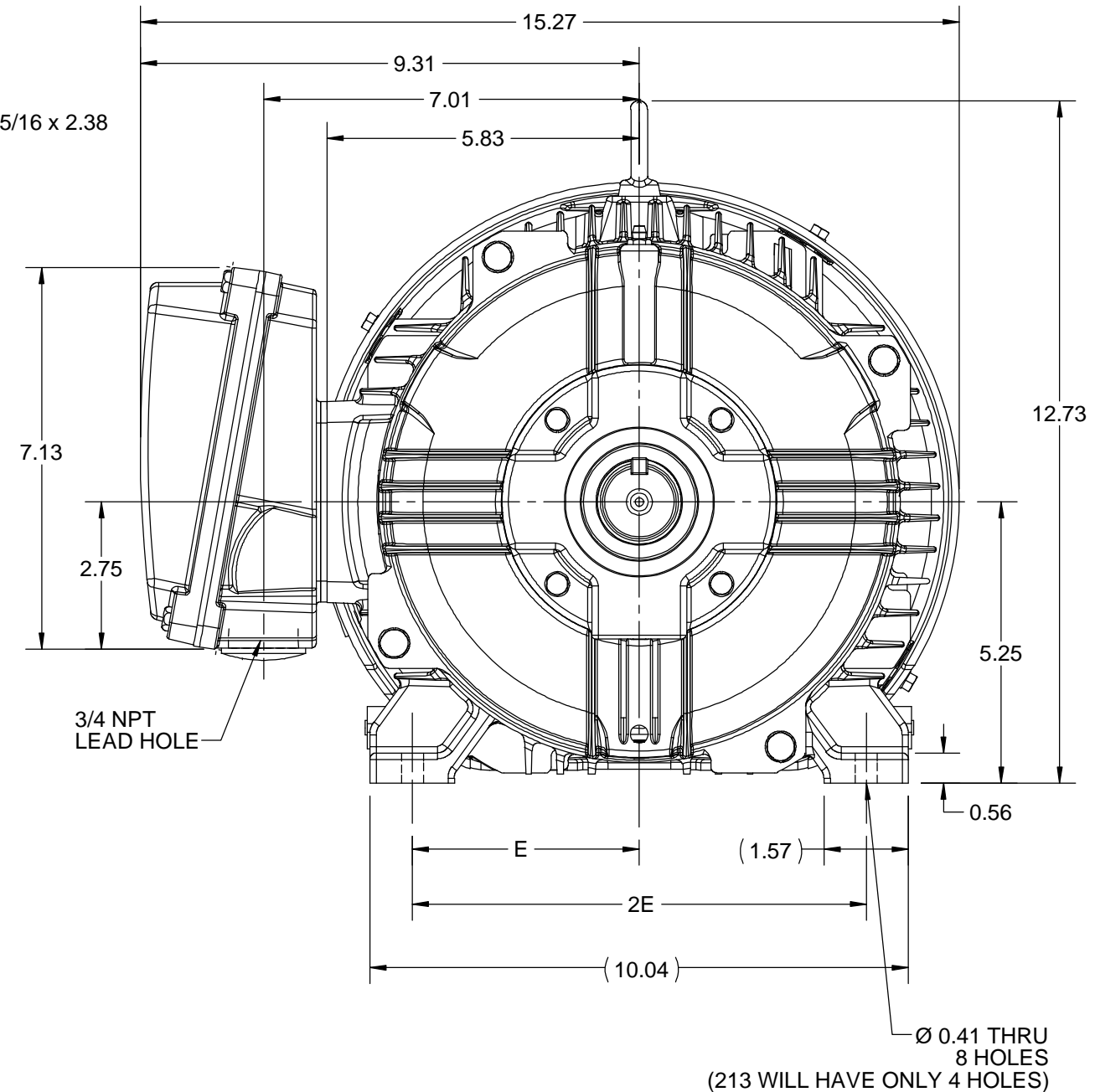
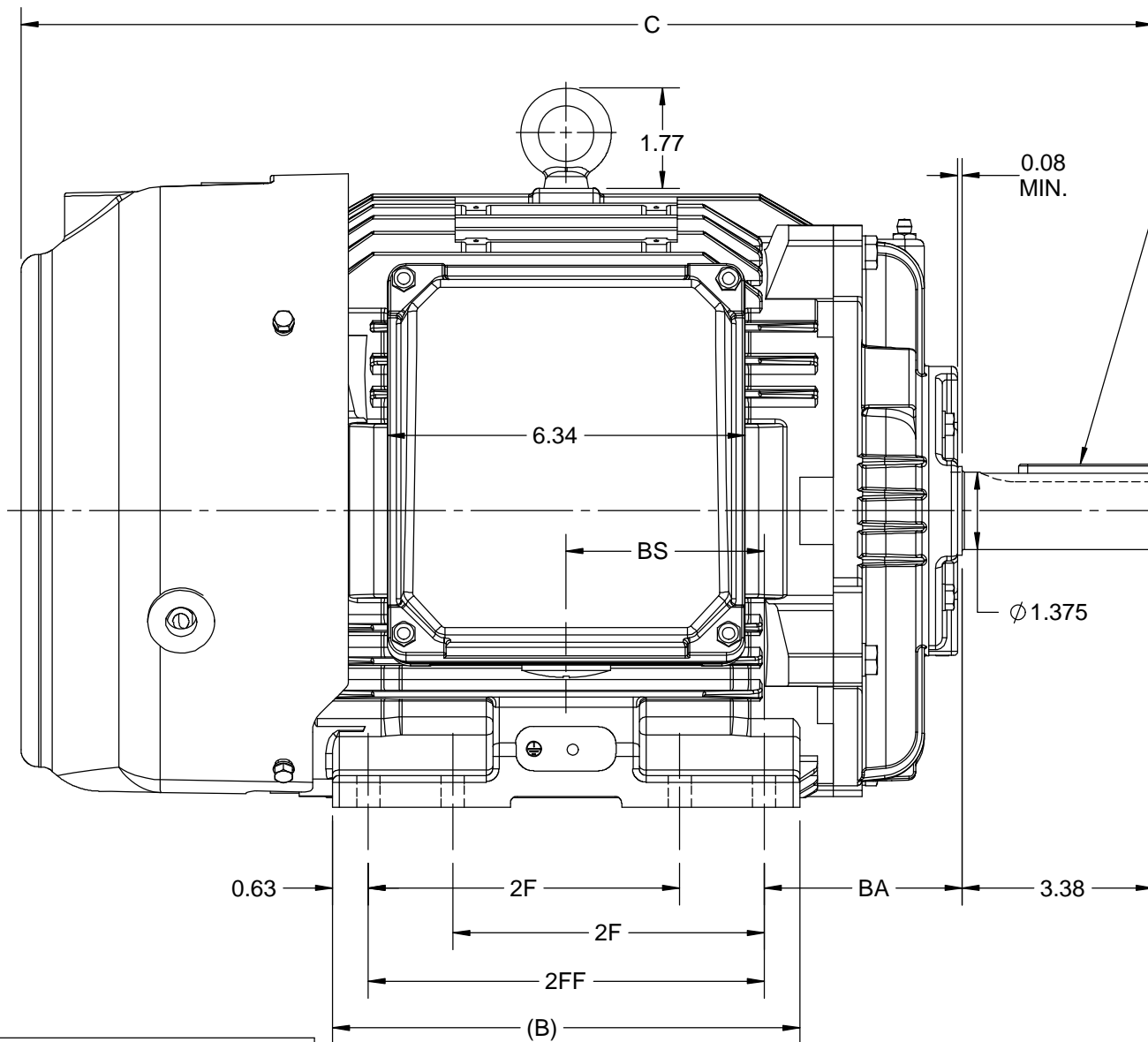

DRAWING REVISION D	REVISION BY VS	REV DATE/© DATE 28-09-2020
ECO ECO-0194527	APPROVED BY GNK	DATE 28-09-2020
ECO DESCRIPTION DRAWING UPDATED COPYRIGHT (PER REVISION DATE) REGAL BELOIT AMERICA, INC. ALL RIGHTS RESERVED. PROPRIETARY AND CONFIDENTIAL INFORMATION - THIS DOCUMENT IS THE PROPERTY OF REGAL BELOIT AMERICA, INC. ("OWNER") AND CONTAINS OWNER'S PROPRIETARY INFORMATION. ANY PERSON, CORPORATION OR OTHER FIRM RECEIVING IT IS DEEMED, BY RECEIVING IT, TO AGREE THAT IT, AND/OR ANY PART OF IT, SHALL NOT BE DISCLOSED TO ANY PERSON, CORPORATION OR OTHER ENTITY, DUPLICATED, AND/OR USED, EXCEPT AS EXPRESSLY APPROVED IN WRITING IN ADVANCE BY OWNER. THIS DOCUMENT SHALL BE RETURNED TO OWNER UPON REQUEST. IT MAY BE SUBJECT TO CERTAIN RESTRICTIONS UNDER APPLICABLE EXPORT CONTROL LAWS AND REGULATIONS.		

PRIMARY DIMENSIONS ARE INCH
mm DIMENSIONS IN [BRACKETS]
ARE FOR REFERENCE ONLY

DRAWN BY BISWA	REGAL ® Regal Beloit America, Inc.
DATE 24/12/2018	
APPROVED BY SBD	DESCRIPTION OUTLINE 213/215T FR NEMA- SD & IEEE841
DATE 24/12/2018	MATERIAL
REFERENCE	PROCESS/FINISH
THIRD ANGLE PROJECTION	SIZE B
	DRAWING NUMBER SS810116
	SHEET 1 OF 1

EE7308

THREE PHASE
DUAL VOLTAGE MOTOR



VIEW OF TERMINAL END

REF.
WINDING DIAGRAM

T8Y, T2Y, T2BL, T4BX, T2EC, T2G
T6BZ, T2B, T6BL, T4AV, T6B, T4B

OPTIONAL CORD
CONNECTION

L1 — WHITE
L2 — RED
L3 — BLACK

NO.	REVISION	BY & DATE	CHK	ANG	TOLERANCES UNLESS SPECIFIED		FINISH	DRAWN RM 11/20/1990				
					DEC.	INCHES						
5	CHG TO REGAL LOGO	SL 09/10/2015	AB					CHK ML 11/21/1990				
4	REVISED IEC NOTATIONS	MSG 11/15/2011	CMN	.X	±.1			APPD SAS 04/24/2003				
3	ADDED IEC NOTATIONS... (U1), (V1) ETC. MU95194	MSG 5/10/2010	MJS	.XX	±.02			SCALE 1=1				
2	ADDED THE OPTIONAL CORD CONNECTION MU46318	RDH 04/24/2003	DRS	.XXX	±.005		TITLE CONNECTION DIAGRAM 3Ø - DUAL VOLTAGE MOTOR	REF				
1	REDRAWN	RM 11/20/1990		.XXXX	±.0005		MAT'L.	FMF				
					±7'30"			PREV				
THIS DRAWING IN DESIGN AND DETAIL IS OUR PROPERTY AND MUST NOT BE USED EXCEPT IN CONNECTION WITH OUR WORK ALL RIGHTS OF DESIGN AND INVENTION ARE RESERVED THIS IS AN ELECTRONICALLY GENERATED DOCUMENT - DO NOT SCALE THIS PRINT							RFP	CAD FILE ee7308	SIZE A	DRAWING NO. EE7308	PAGE OF 5	REV. 5
							DIST WP					



Regal Beloit America, Inc.



DATA VOLTS: 460

CERTIFICATION DATA SHEET

CONN. DIAGRAM: EE7308
 OUTLINE: SS810116-215T
 WINDING: HE31326015 NONE 2

MODEL #: 215TTFC6881
 CAT #: E474B
 MOUNTING: F1/F2 CAPABLE

TYPICAL MOTOR PERFORMANCE DATA

HP	KW	SYNC RPM	FL RPM	FRAME	ENCLOSURE	TYPE	KVA CODE		DESIGN
5	3.7	1200	1180	215T	TEFC	TFC	J		A
PH	HZ	VOLTS	AMPS	START TYPE	DUTY	INSL	S.F.	AMB (° C)	ELEV.(Ft)
3	60	230/460	13.6/6.8	LINE OR INVERTER	CONT	H	1.15	40	3300
F.L. EFF	89.5	3/4 LD EFF	89.5	1/2 LD EFF	89.0	GTD EFF	ELECT. TYPE		
F.L. PF	77.5	3/4 LD PF	72.0	1/2 LD PF	61.0	88.5	SQ CAGE INV RATED		
F.L. TORQUE	LR AMPS @ 460 V	L.R. TORQUE		B.D. TORQUE		F.L. RISE (° C)			
22.3 LB-FT	48.0	41.0 LB-FT	184%	62.5 LB-FT	280%	45			
SOUND PRESSURE @	SOUND	ROTOR WK ²	MAX. LOAD WK ²	SAFE STALL TIME	STARTS/HOUR	APROX. MOTOR			
55 dBA	64 dBA	1.05 LB-FT ²	110 LB-FT ²	25 SEC.	2	209	LB.		

*** SUPPLEMENTAL INFORMATION ***

DE BRACKET TYPE	ODE BRACKET TYPE	MOUNT TYPE	MOTOR ORIENTATION	SEVERE DUTY	HAZARDOUS LOCATION	DRIP COVER	SCREENS	PAINT	
STANDARD	STANDARD	RIGID	HORIZONTAL	PREMIUM SEVERE DUTY	DIVISION 2 T2B	NO	NONE	BLUE (EPOXY)	

BEARINGS		GREASE	SHAFT TYPE	SPECIAL DE	SPECIAL ODE	SHAFT MATERIAL	FRAME MATERIAL
DE	ODE						
BALL	BALL	POLYREX EM	T	NONE	NONE	1144 STRESSPROOF (C-223)	CAST IRON
6308	6208						

THERMOSTATS	PROTECTORS	WDG RTD's	BRG RTD's	THERMISTORS	CONTROL	SPACE HEATERS
NONE	NOT	NONE	NONE	NONE	FALSE	NA

R1 (ohms/ph)	R2 (ohms/ph)	X1 (ohms/ph)	X2 (ohms/ph)	Xm (ohms/ph)	VIBRATION (in/sec)
1.613	0.744	4.834	6.748	78.838	0.080

If Inverter equals NONE, contact factory for further information

* N O T E S *	INVERTER TORQUE: CONSTANT 20:1 INV. HP SPEED RANGE: NONE	
	ENCODER: NONE NONE NONE PPR	
	BRAKE: NONE NONE NONE FT-LB: NA VOLTAGE: NONE HZ:	
	PREPARED BY: ANUSHA M DATE: 3/10/2020	

FORM: 3531 REV_4 2/27/06

** Subject to change without notice.

Data Sheet

215TTFC6881

Date: 3/10/2020
 Customer: _____
 Attention: _____
 Submitted by: ANUSHA M



Submittal

Data @ 460 V

Motor Load Data

Load	0%	25%	50%	75%	100%	115%	125%	LR
Current (Amps)	3.2	3.5	4.3	5.4	6.8	7.7	8.4	48.0
Torque (ft-lb)	0.00	5.5	11.0	16.6	22.3	25.7	28.1	41.0
RPM	1200	1195	1190	1185	1180	1,175	1170	0
Efficiency (%)		84.8	89.0	89.5	89.5	89.5	88.5	
P.F. (%)	6.0	39.5	61.0	72.0	77.5	78.5	79.0	45.0

Motor Speed Data

	LR	Pull-Up	BD	Rated	Idle
Speed (RPM)	0	600	1075	1180	1200
Current (Amps)	48.0	41.0	23.0	6.8	3.2
Torque (ft-lb)	41.0	35.0	62.5	22.3	0.00

Information Block

HP	5.0			
Sync. RPM	1200			
Frame	215			
Enclosure	TEFC			
Construction	TFC			
Voltage	230/460 V			
Frequency	60 Hz			
Design	B			
LR Code letter	J			
Service Factor	1.15			
Temp Rise @ FL	45 °C			
Duty	CONT			
Ambient	50 °C			
Elevation	1,000 feet			
Rotor/Shaft wk ²	1.05 Lb-Ft ²			
Ref Wdg	HE31326015 NONE			
Sound Pressure @ 1M	55 dBA			
VFD Rating	CONSTANT 20:1			
Outline Dwg	SS810116-215T			
Conn. Diag	EE7308			
Additional Specifications:				
0				
0				
EQUIV CKT (OHMS / PHASE)				
R1	R2	X1	X2	Xm
1.6130	0.7440	4.8340	6.7480	78.8380

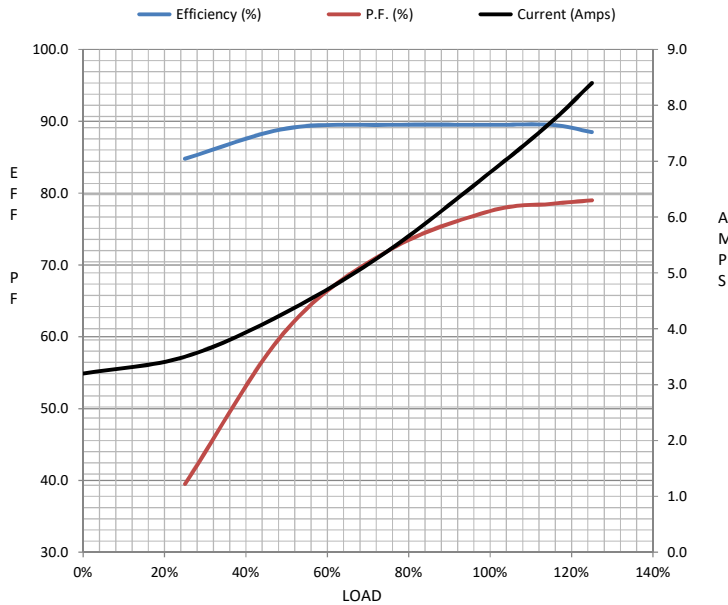

Speed -Torque Curve

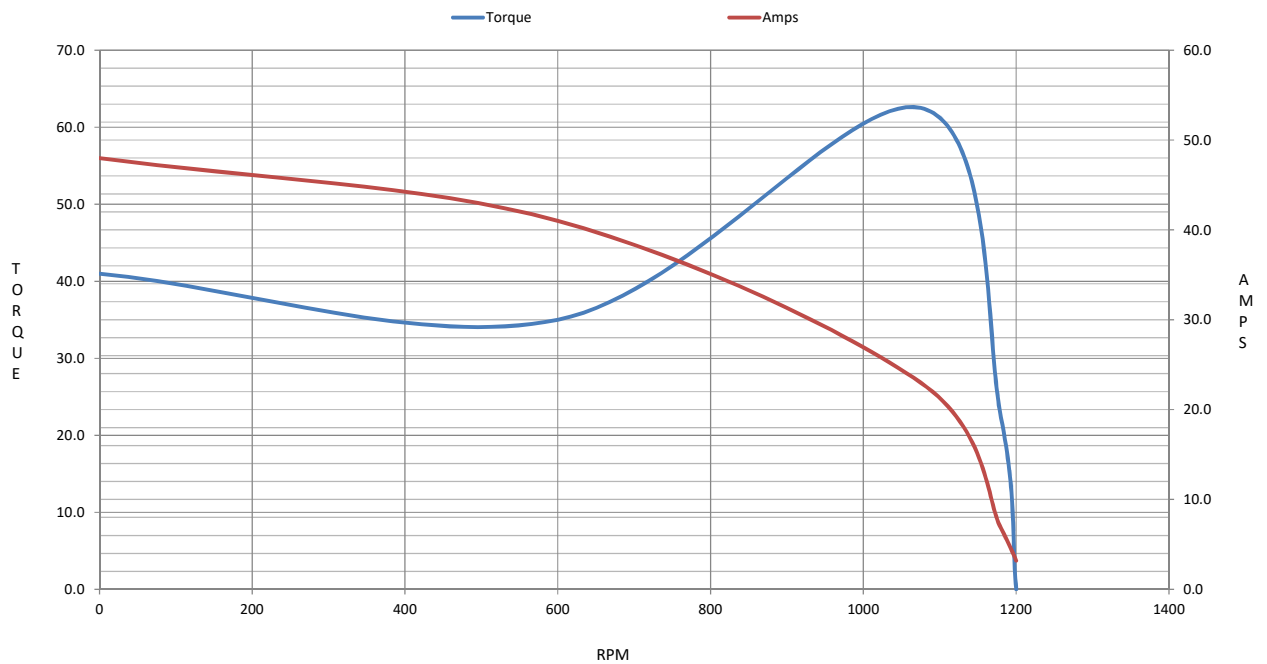

EC Declaration of Conformity

The undersigned representing
the manufacturer:

Regal Beloit America
100 East Randolph St.
Wausau, WI 54401

and the authorized representative
established within the Community:

Marathon Electric UK
6F Thistleton Road Ind. Estate
Market Overton
Oakham, Rutland LE15 7PP UK

are committed to providing customers with products that comply with applicable regulations and international protocols to which they are subject, including the requirements of the European Parliament Directive on the Harmonization of the laws relating to electrical equipment designed for use within certain voltage limits (2014/35/EU).

Regal Beloit America declares that the following product(s), to which this declaration relates, are in conformity with the relevant sections of the EC standards listed below.

This statement supersedes any statements previously issued pertaining to the product(s) listed below and is subject to change without notice.

Model No : 215TTFC6881

(Model No. may contain prefix and/or suffix characters)

Catalog No : E474B

Rework No : N/A

Directives :

Low Voltage Directive 2014/35/EU

Harmonized Standards Used :

EN 60034-1: 2010 (IEC 60034-1: 2010)

EN 60034-5: 2001/A1:2007 (IEC 60034-5: 2000/A1:2006)

Authorized Representative:



Michael A. Logsdon
Vice President, Technology

Authorized Representative in the Community:



Julian Clark
Marketing Engineer

Created on 09/01/2022

CE 22