

Product Information Packet

April 30, 2019

Data shown is for the current revision model #. Ensure your nameplate model # matches.

Model Number:	5KS254CWL305
Catalog Number:	E517
Instruction Manual:	GEI-M1049
Connection Diagram:	GEM2034E-FIG9
Outline Drawing:	358B6503AA

Accessory Connection Diagrams			
Bearing Thermocouple:	None	Heater:	None
RTD:	None	Thermistor:	None
Thermostat:	3027JE-2A	Winding Thermocouple:	None
Bearing RTD:	None		

Table of Contents	
Specification	01
Performance Characteristics	02
Outline Drawing	03
Connection Drawing(s)	04

Marks:

MODEL NUMBER:	5KS254CWL305	Estimated Weight:	400 Lbs
Outline Drawing:	358B6503AA	Time Rating:	CONT
Connection Diagram:	GEM2034E-FIG9	Enclosure:	TEFC
Instruction Book:	GEI-M1049	Encl Construction:	XP
Design Code:	NA	Ambient Max(°C):	40
Type:	KS	Alt Ambient Max(°C):	55
Frame:	254T	Insulation Class:	F
Phases:	3	NEMA Design:	B
Poles:	6	Nominal Efficiency:	91.0 %
Output Power:	7.5HP 5.5KW	Guaranteed Efficiency:	89.5 %
RPM:	1182	3/4 Load Efficiency:	91.0 %
Voltage:	230/460	KVA Code:	H
Hertz:	60	Max KVAR:	3.4
Amps - FL:	17.8/8.9	Power Factor:	86.1%
Service Factor:	1.15	Bearing - DE:	6309-C3
Alt Service Factor:	1.0	Bearing - ODE:	6309-C3

Enclosure is Totally Enclosed Fan-Cooled

Stamped Nameplate Notes:**Additional Information:**

THERMOSTAT FOR: TRIP 145+/-5 DEG C
 THERMOSTAT LEADS: 3 NC TO TERMINATE IN MAIN CB
 ROTATION:CCW VIEWED FROM ODE
 CLASS /GAS GROUP:CL I GR C and D, CLASS II GR F and G
 CBOX SIZE:291 CU INCH
 INVERTER DUTY PER NEMA MG1 PART 31
 INVERTER RATED PWM 10:1 VARIABLE TORQUE, 5:1 CONSTANT TORQUE, 1.0 SF
 UL CERTIFICATION SUITABLE FOR INSTALLATION IN –
 - THE UNITED STATES, NIGERIA AND KUWAIT

Performance Characteristic:

LOAD %	125.0	115.0	100.0	75.0	50.0	25.0	0.0
% EFF	90.47	90.72	91.70	91.50	90.16	86.13	0
% PF	86.4	86.1	80.0	78.0	72.5	51.0	17.5
AMPS(460V)	11.1	10.1	9.4	7.0	5.3	3.9	1.7

TORQUE(FL) LB-FT 33.0 TORQUE(LR)%FL 181.0 TORQUE(BD)%FL 303.3
 AMPS(LR 460V) 65.7 PF AT START 0.35%

Other Useful Information for Application:

Rotor Inertia: Lb-Ft ² (Kg-m ²):	0.85(0.036)
Max load inertia: Lb-Ft ² (Kg-m ²):	39(1.64)
Load Type:	Square Torque/Speed Characteristic
Voltage:	100%
Number of starts per hour:	2 Cold or 1 Hot
Acceleration Time with maximum inertia (sec):	4.1
Safe stall time (sec): Cold/Hot	70/30

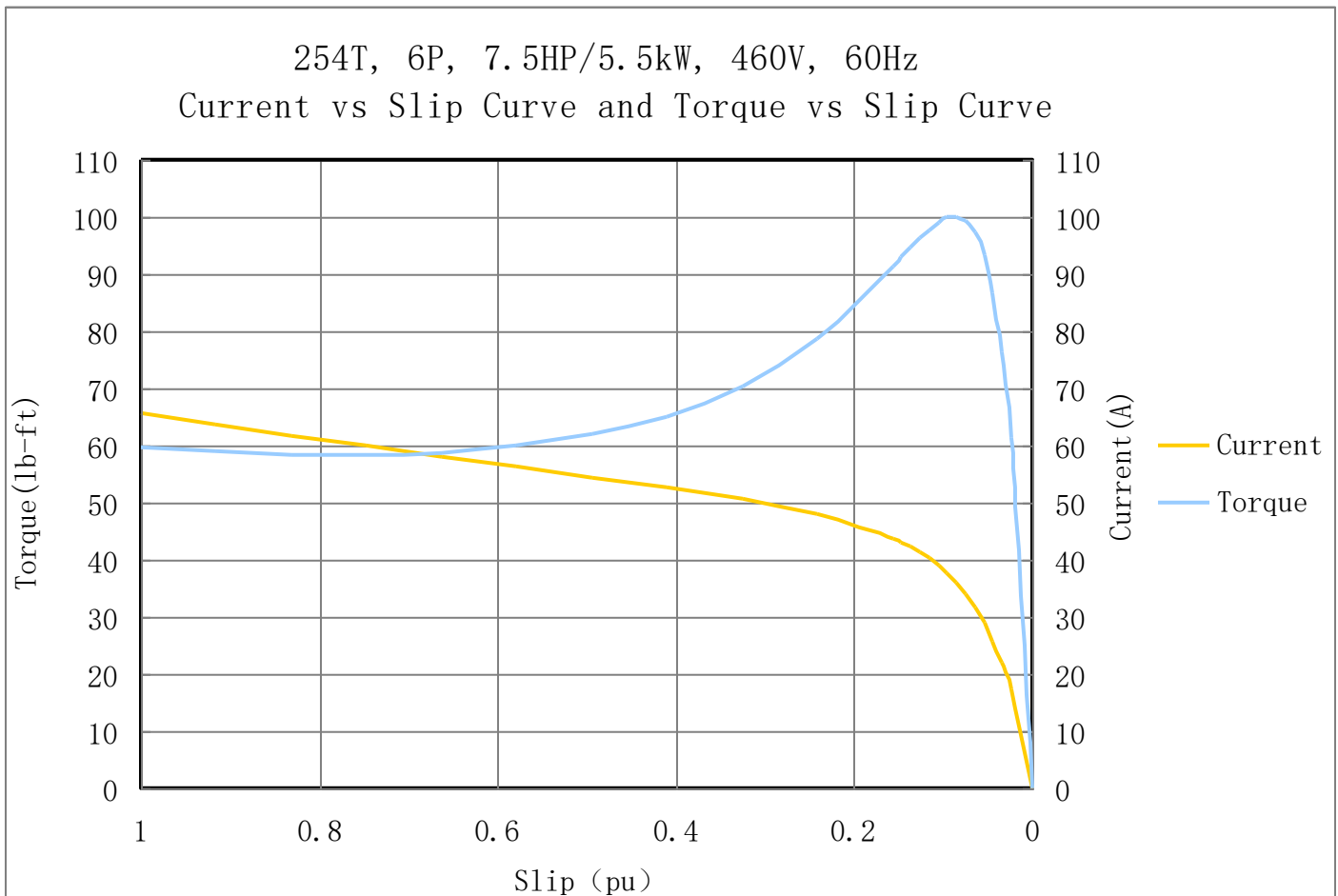

Marks:

- NOTES:
1. CONDUIT BOX IS SUITABLE FOR UP, DOWN OR EITHER SIDE ENTRY.
 2. F1 ASSEMBLY AS SHOWN.
 3. ALL DIMENSIONS ARE IN INCHES.

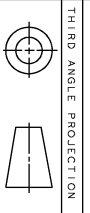
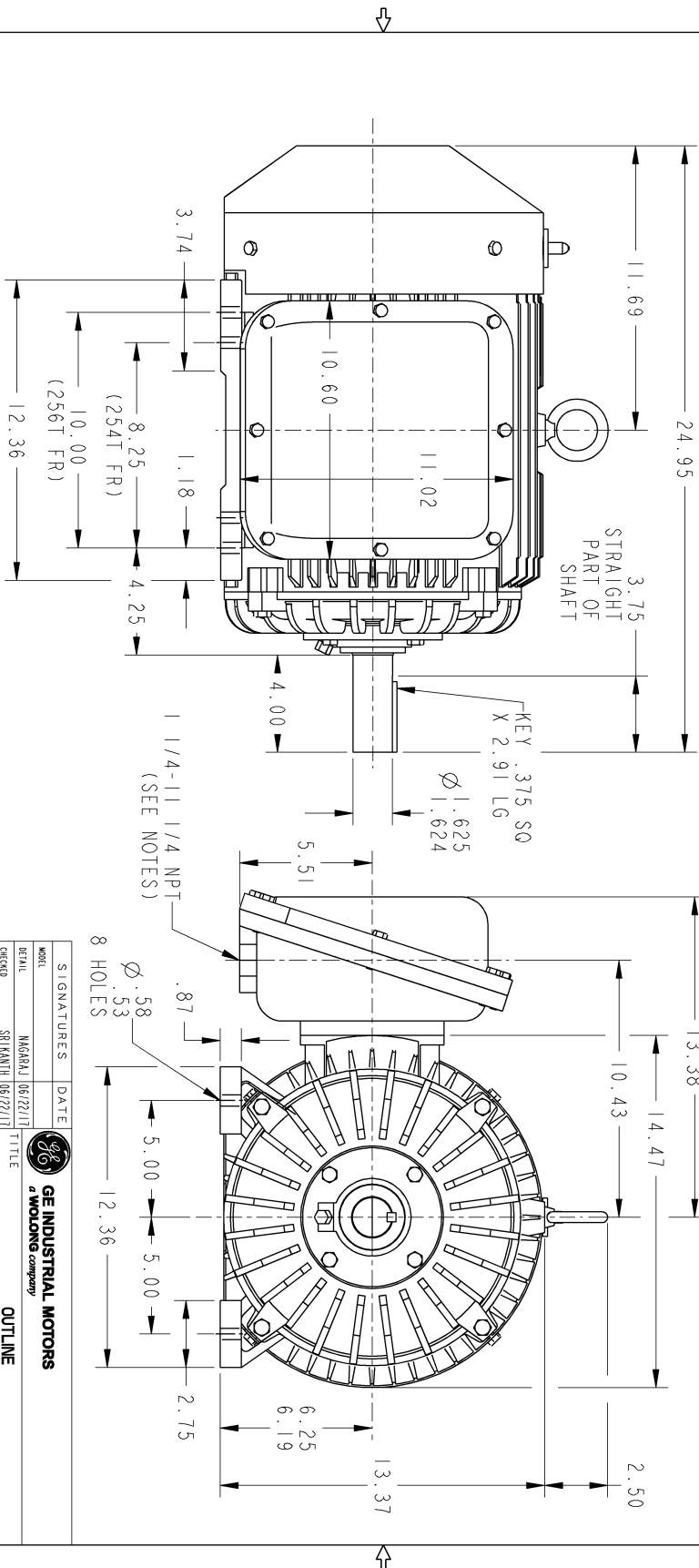

THIRD ANGLE PROJECTION

PROPRIETARY INFORMATION
 All rights reserved. This document and the information it contains is the property of the Wabag Electric America LLC and/or its affiliates. It has been provided solely for internal use only for design, engineering, manufacturing, and/or service purposes. It is strictly prohibited to be reproduced, stored in a retrieval system, or transmitted in any form or by any means, electronic, mechanical, photocopying, recording, or by any information storage and retrieval system, without the prior written permission of the Wabag Electric America LLC.

REV.	DESCRIPTION	DATE	APPROVED
1	ISSAC #17-0780	10/24/17	SRI KANTH
2	ISSAC #18-0869	SREDEVI 01/04/19	PRASHANTH
3	ISSAC #19-0358	NAGARAJ 04/22/19	SAHID

SIGNATURES	DATE
MODEL: NAGARAJ 06/22/17	
DRAWN: SRI KANTH 06/22/17	
CHECKED: SRI KANTH 06/22/17	
ENG'G: SRI KANTH 06/22/17	
W/E:	
QUALITY:	
ISSUED: SRI KANTH 06/22/17	
SOLD ID MODEL: MODEL MAKE	

GE INDUSTRIAL MOTORS a wolong company	
TITLE 254T / 256T TERC EXPLOSION PROOF 291 CU. IN. C/BOX	
SIZE DRAWING B	REF. No.:
SCALE: NTS	REV. No.:
358B6503AA	REV. No.:
SHEET 1 OF 1	SHEET 1 OF 1

Marks:

Connection Diagram
GEM2034E-FIG9

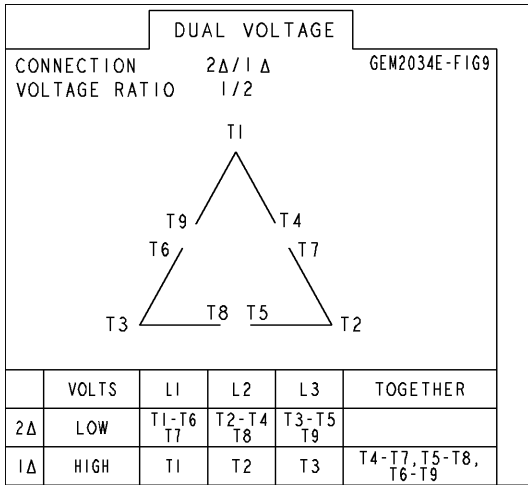

Thermostat Connection
3027JE-2A

