

# Product Information Packet

April 30, 2019

Data shown is for the current revision model #. Ensure your nameplate model # matches.

<b>Model Number:</b>	<b>5KS284CWL305</b>
<b>Catalog Number:</b>	<b>E523</b>
<b>Instruction Manual:</b>	GEI-M1049
<b>Connection Diagram:</b>	GEM2034E-FIG9
<b>Outline Drawing:</b>	358B6504AA

Accessory Connection Diagrams			
<b>Bearing Thermocouple:</b>	None	<b>Heater:</b>	None
<b>RTD:</b>	None	<b>Thermistor:</b>	None
<b>Thermostat:</b>	3027JE-2A	<b>Winding Thermocouple:</b>	None
<b>Bearing RTD:</b>	None		

Table of Contents	
Specification	01
Performance Characteristics	02
Outline Drawing	03
Connection Drawing(s)	04

**Marks:**

<b>MODEL NUMBER:</b>	<b>5KS284CWL305</b>	<b>Estimated Weight:</b>	528 Lbs
<b>Outline Drawing:</b>	358B6504AA	<b>Time Rating:</b>	CONT
<b>Connection Diagram:</b>	GEM2034E-FIG9	<b>Enclosure:</b>	TEFC
<b>Instruction Book:</b>	GEI-M1049	<b>Encl Construction:</b>	XP
<b>Design Code:</b>	NA	<b>Ambient Max(°C):</b>	40
<b>Type:</b>	KS	<b>Alt Ambient Max(°C):</b>	55
<b>Frame:</b>	284T	<b>Insulation Class:</b>	F
<b>Phases:</b>	3	<b>NEMA Design:</b>	B
<b>Poles:</b>	6	<b>Nominal Efficiency:</b>	91.7 %
<b>Output Power:</b>	15HP 11kW	<b>Guaranteed Efficiency:</b>	90.2 %
<b>RPM:</b>	1180	<b>3/4 Load Efficiency:</b>	92.0 %
<b>Voltage:</b>	230/460	<b>KVA Code:</b>	G
<b>Hertz:</b>	60	<b>Max KVAR:</b>	5.7
<b>Amps - FL:</b>	35.8/17.9	<b>Power Factor:</b>	84.0%
<b>Service Factor:</b>	1.15	<b>Bearing - DE:</b>	6310-C3
<b>Alt Service Factor:</b>	1.0	<b>Bearing - ODE:</b>	6310-C3

**Enclosure is Totally Enclosed Fan-Cooled**

---

**Stamped Nameplate Notes:****Additional Information:**

THERMOSTAT FOR: TRIP 145+/-5 DEG C  
 THERMOSTAT LEADS: 3 NC TO TERMINATE IN MAIN CB  
 ROTATION:CCW VIEWED FROM ODE  
 CLASS /GAS GROUP:CL I GR C and D, CLASS II GR F and G  
 CBOX SIZE:291 CU INCH  
 INVERTER DUTY PER NEMA MG1 PART 31  
 INVERTER RATED PWM 10:1 VARIABLE TORQUE, 5:1 CONSTANT TORQUE, 1.0 SF  
 UL CERTIFICATION SUITABLE FOR INSTALLATION IN –  
 - THE UNITED STATES, NIGERIA AND KUWAIT

**Performance Characteristic:**

LOAD %	125.0	115.0	100.0	75.0	50.0	25.0	0.0
% EFF	92.02	92.32	91.70	92.00	92.89	90.57	0.00
% PF	87.1	86.8	84.0	79.0	73.7	51.6	16.9
AMPS(460V)	21.57	19.83	17.9	13.51	10.05	7.36	3.21

		TORQUE(LR)%F		TORQUE(BD)%F		
TORQUE(FL) LB-FT	65.37	L	217	L	274.2	
AMPS(LR 460V)	116.0	PF AT START	0.35%			

**Other Useful Information for Application:**

Rotor Inertia: Lb-Ft <sup>2</sup> (Kg-m <sup>2</sup> ):	3.8(0.16)
Max load inertia: Lb-Ft <sup>2</sup> (Kg-m <sup>2</sup> ):	200(8.4)
Load Type:	Square Torque/Speed Characteristic
Voltage:	100%
Number of starts per hour:	2 Cold or 1 Hot
Acceleration Time with maximum inertia (sec):	5.3
Safe stall time (sec): Cold/Hot	60/22

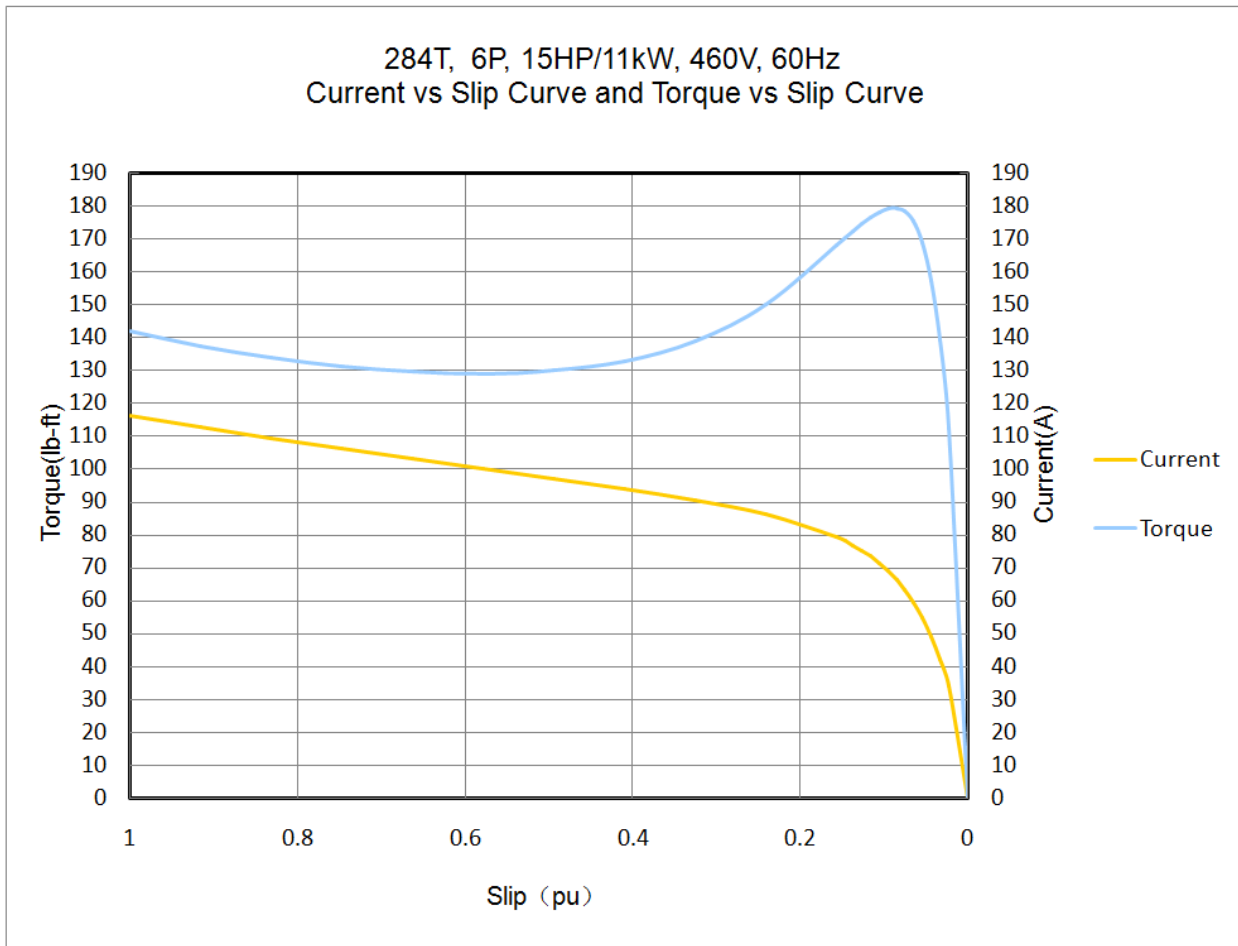

Marks:

- NOTES:
1. CONDUIT BOX IS SUITABLE FOR UP, DOWN OR EITHER SIDE ENTRY.
  2. FL ASSEMBLY AS SHOWN.
  3. ALL DIMENSIONS ARE IN INCHES.

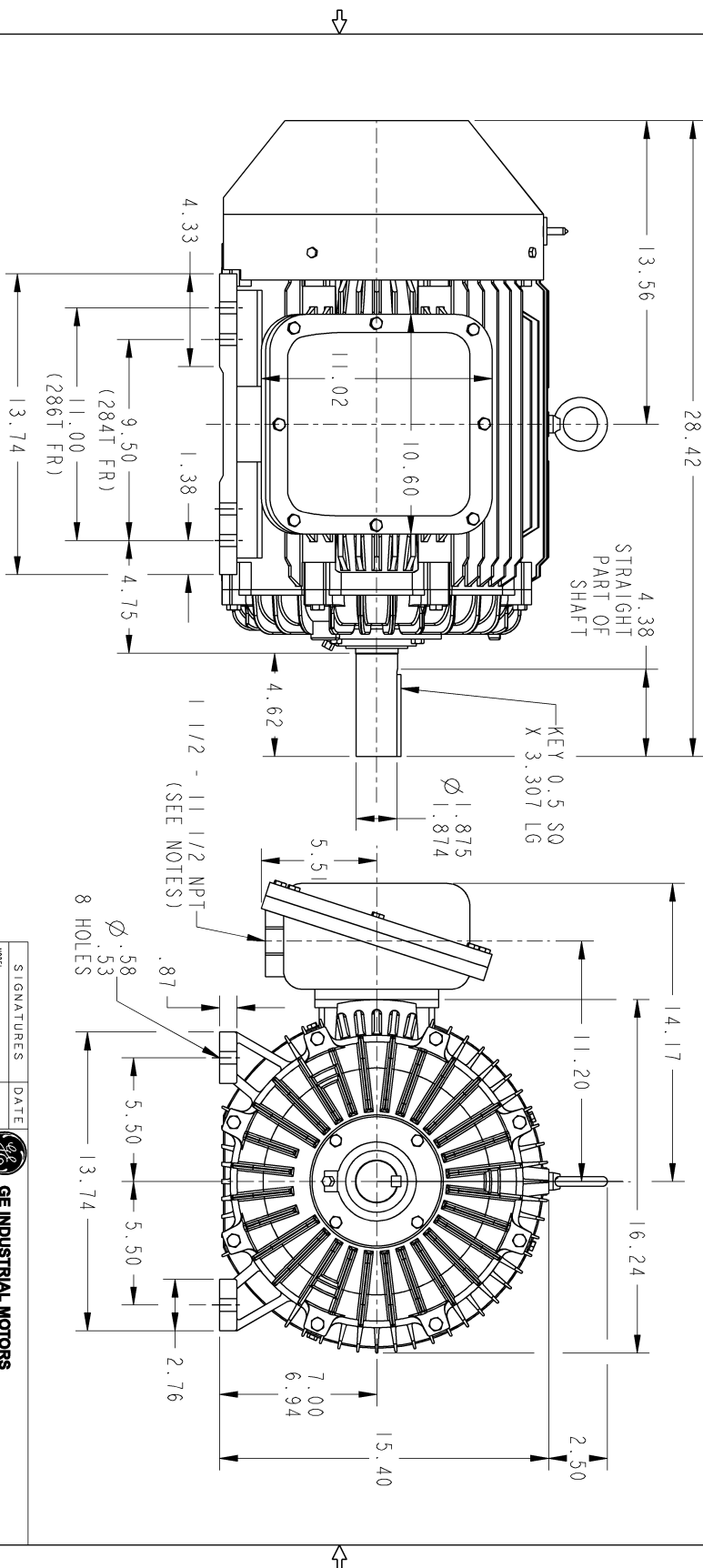

PROPRIETARY INFORMATION  
 All rights reserved. This document and the information it contains is the property of the Wabag Electric America LLC and/or its affiliates. It has been provided solely for internal use only. Reproduction, selling, importing, copying, distribution, or transmission in any form or by any means, electronic or mechanical, including photocopying, recording, or by any information storage and retrieval system, is strictly prohibited except as expressly authorized in writing by the Wabag Electric America LLC.

REV.	DESCRIPTION	DATE	APPROVED
1	ISSAC #17-0780	10/24/17	SRI KANTH
2	ISSAC #18-0869	01/07/18	PRASHANTH
3	ISSAC #19-0358	04/22/19	SAHID

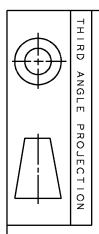

SIGNATURES	DATE
MODEL: NAGARAJ	06/22/17
DRAWN: SRI KANTH	06/22/17
CHECKED: SRI KANTH	06/22/17
ENG'G: SRI KANTH	06/22/17
QUALITY: SRI KANTH	06/22/17
ISSUED: SRI KANTH	06/22/17

SCALE: NTS	REF. No.:
SHEET 1 OF 1	

**GE INDUSTRIAL MOTORS**  
 a WOLONG company

OUTLINE  
 294T/284T TFFC EXPLOSION PROOF  
 291 CU IN C/BOX

**358B6504AA** REV  
**003**

Marks:

**Connection Diagram**  
**GEM2034E-FIG9**

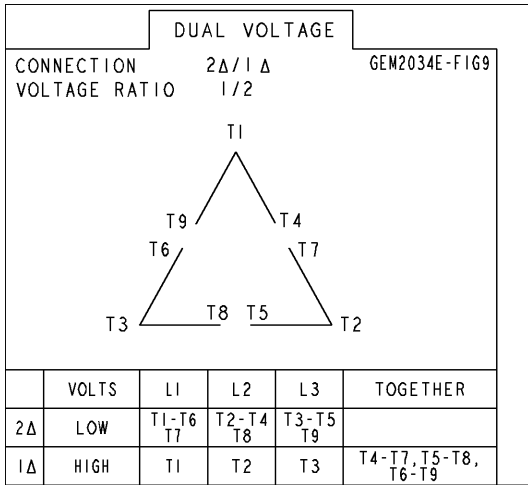

**Thermostat Connection**  
**3027JE-2A**

