

Product Information Packet

April 30, 2019

Data shown is for the current revision model #. Ensure your nameplate model # matches.

Model Number:	5KS326CWL205
Catalog Number:	E537
Instruction Manual:	GEI-M1049
Connection Diagram:	GEM2034E-FIG9
Outline Drawing:	358B6505AA

Accessory Connection Diagrams			
Bearing Thermocouple:	None	Heater:	None
RTD:	None	Thermistor:	None
Thermostat:	3027JE-2A	Winding Thermocouple:	None
Bearing RTD:	None		

Table of Contents	
Specification	01
Performance Characteristics	02
Outline Drawing	03
Connection Drawing(s)	04

Marks:

MODEL NUMBER:	5KS326CWL205	Estimated Weight:	739 Lbs
Outline Drawing:	358B6505AA	Time Rating:	CONT
Connection Diagram:	GEM2034E-FIG9	Enclosure:	TEFC
Instruction Book:	GEI-M1049	Encl Construction:	XP
Design Code:	NA	Ambient Max(°C):	40
Type:	KS	Alt Ambient Max(°C):	55
Frame:	326T	Insulation Class:	F
Phases:	3	NEMA Design:	B
Poles:	4	Nominal Efficiency:	94.5 %
Output Power:	50HP 37KW	Guaranteed Efficiency:	93.6 %
RPM:	1785	3/4 Load Efficiency:	94.6 %
Voltage:	230/460	KVA Code:	G
Hertz:	60	Max KVAR:	14.8
Amps - FL:	114/57	Power Factor:	86.2%
Service Factor:	1.15	Bearing - DE:	6312-C3
Alt Service Factor:	1.0	Bearing - ODE:	6312-C3

Enclosure is Totally Enclosed Fan-Cooled

Stamped Nameplate Notes:**Additional Information:**

THERMOSTAT FOR: TRIP 145+/-5 DEG C
THERMOSTAT LEADS: 3 NC TO TERMINATE IN MAIN CB
ROTATION:CCW VIEWED FROM ODE
CLASS /GAS GROUP:CL I GR C and D, CLASS II GR F and G
CBOX SIZE:281 CU INCH
INVERTER DUTY PER NEMA MG1 PART 31
INVERTER RATED PWM 10:1 VARIABLE TORQUE, 5:1 CONSTANT TORQUE, 1.0 SF
UL CERTIFICATION SUITABLE FOR INSTALLATION IN –
- THE UNITED STATES, NIGERIA AND KUWAIT

Performance Characteristic:

LOAD %	125.0	115.0	100.0	75.0	50.0	25.0	0.0
% EFF	94.44	94.63	94.50	94.60	94.89	93.19	0.00
% PF	89.8	89.7	86.2	82.0	81.0	61.2	9.4
AMPS(460V)	68.50	62.87	57.00	42.00	30.23	20.35	8.90

TORQUE(FL) LB-FT 146.13 TORQUE(LR)%FL 168.0 TORQUE(BD)%FL 263.0
 AMPS(LR 460V) 361.2 PF AT START 0.31%

Other Useful Information for Application:

Rotor Inertia: Lb-Ft ² (Kg-m ²):	18.27(0.77)
Max load inertia: Lb-Ft ² (Kg-m ²):	232(9.8)
Load Type:	Square Torque/Speed Characteristic
Voltage:	100%
Number of starts per hour:	2 Cold or 1 Hot
Acceleration Time with maximum inertia (sec):	4.9
Safe stall time (sec): Cold/Hot	75/30

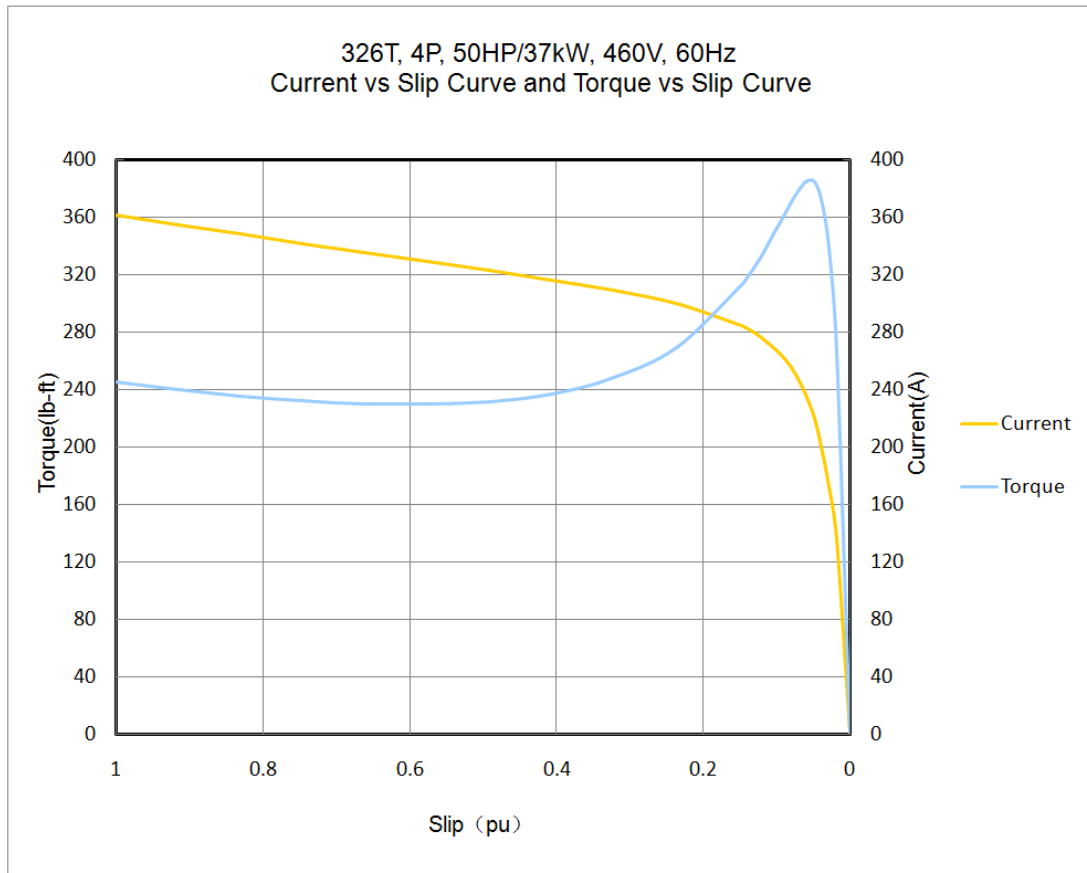

Marks:

- NOTES:
1. CONDUIT BOX IS SUITABLE FOR UP, DOWN OR EITHER SIDE ENTRY.
 2. FI ASSEMBLY AS SHOWN.
 3. ALL DIMENSIONS ARE IN INCHES.

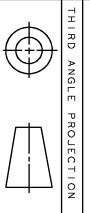
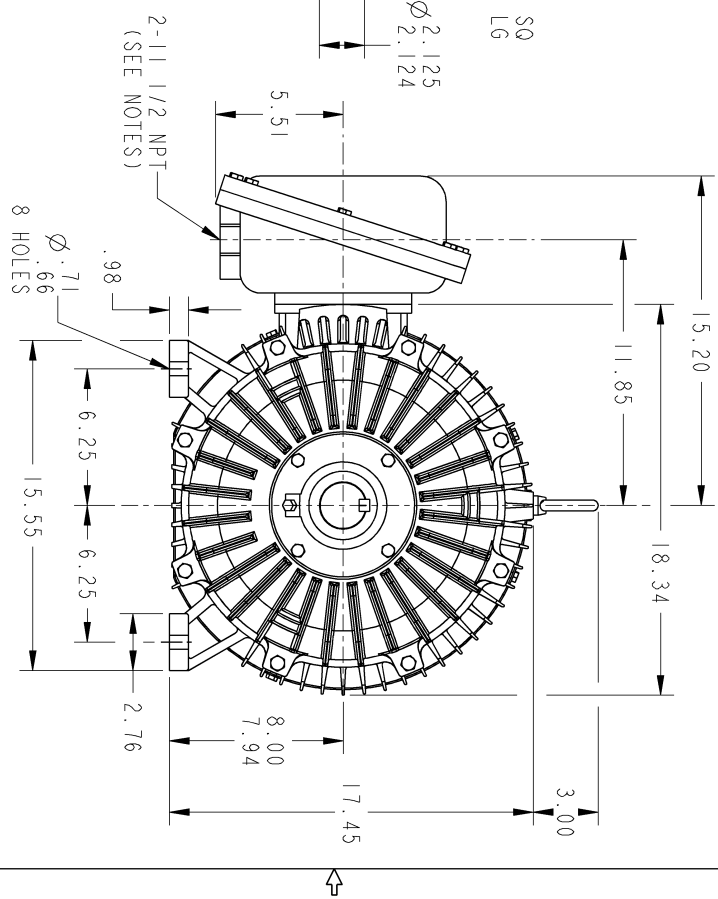
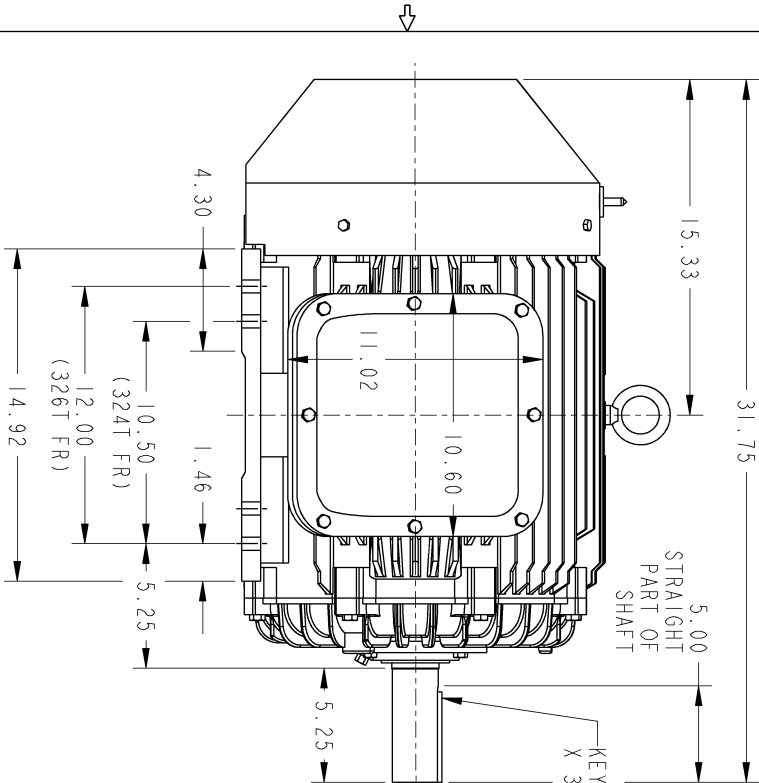

PROPRIETARY INFORMATION
 © Copyright 2018 Wabag Electric America LLC. ALL RIGHTS RESERVED.
 All rights reserved. This document and the information it contains is the property of Wabag Electric America LLC and/or its affiliates. It has been provided solely for the use of the recipient and is not to be distributed, copied, reproduced, stored in a retrieval system, or transmitted in any form or by any means, electronic, mechanical, photocopying, recording, or by any information storage and retrieval system, without the prior written permission of Wabag Electric America LLC. Any unauthorized use, reproduction, or distribution is strictly prohibited except as expressly authorized in writing by the Wabag Electric America LLC.

REV.	DESCRIPTION	DATE	APPROVED
1	ISSAC #17-0780	10/24/17	SAHID
2	ISSAC #18-0869	01/07/19	PRASHANTH
3	ISSAC #19-0358	04/22/19	SAHID

SIGNATURES	DATE
MODEL: MAGARAJ	06/22/17
DRAWN: SRIKANTH	06/22/17
CHECKED: SRIKANTH	06/22/17
ENG'G: SRIKANTH	06/22/17
W/E:	
QUALITY:	
ISSUED: SRIKANTH	06/22/17
SOLD ID MODEL: MODEL MAKE:	

TITLE	SCALE	REF. No.
GE INDUSTRIAL MOTORS a wolong company	NTS	
OUTLINE		
324T/326T TFC EXPLOSION PROOF		
281 CU. IN. C/BOX		
358B6505AA		
REV. 003		
SHEET 1 OF 1		

Marks:

Connection Diagram
GEM2034E-FIG9

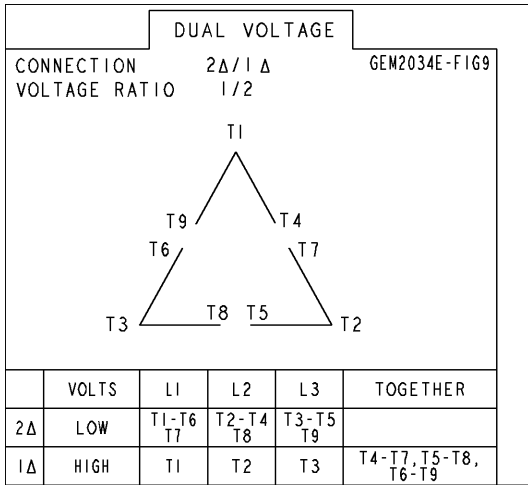

Thermostat Connection
3027JE-2A

