

Product Information Packet

April 30, 2019

Data shown is for the current revision model #. Ensure your nameplate model # matches.

Model Number:	5KS447CWL208
Catalog Number:	E555
Instruction Manual:	GEI-M1049
Connection Diagram:	GEM2034E-FIG8
Outline Drawing:	358B6509AA

Accessory Connection Diagrams			
Bearing Thermocouple:	None	Heater:	None
RTD:	None	Thermistor:	None
Thermostat:	3027JE-2A	Winding Thermocouple:	None
Bearing RTD:	None		

Table of Contents	
Specification	01
Performance Characteristics	02
Outline Drawing	03
Connection Drawing(s)	04

Marks:

MODEL NUMBER:	5KS447CWL208	Estimated Weight:	2651 Lbs
Outline Drawing:	358B6509AA	Time Rating:	CONT
Connection Diagram:	GEM2034E-FIG8	Enclosure:	TEFC
Instruction Book:	GEI-M1049	Encl Construction:	XP
Design Code:	NA	Ambient Max(°C):	40
Type:	KS	Alt Ambient Max(°C):	55
Frame:	447T	Insulation Class:	F
Phases:	3	NEMA Design:	B
Poles:	4	Nominal Efficiency:	96.2 %
Output Power:	200HP 148KW	Guaranteed Efficiency:	95.4 %
RPM:	1786	3/4 Load Efficiency:	96.2 %
Voltage:	460	KVA Code:	G
Hertz:	60	Max KVAR:	45.2
Amps - FL:	230.2	Power Factor:	85.4%
Service Factor:	1.15	Bearing - DE:	6318-C3
Alt Service Factor:	1.0	Bearing - ODE:	6314-C3

Enclosure is Totally Enclosed Fan-Cooled

Stamped Nameplate Notes:**Additional Information:**

THERMOSTAT FOR: TRIP 145+/-5 DEG C
 THERMOSTAT LEADS: 3 NC TO TERMINATE IN MAIN CB
 ROTATION:CCW VIEWED FROM ODE
 CLASS /GAS GROUP:CL I GR C and D, CLASS II GR F and G
 CBOX SIZE:901 CU INCH
 INVERTER DUTY PER NEMA MG1 PART 31
 INVERTER RATED PWM 10:1 VARIABLE TORQUE, 5:1 CONSTANT TORQUE, 1.0 SF
 UL CERTIFICATION SUITABLE FOR INSTALLATION IN –
 - THE UNITED STATES, NIGERIA AND KUWAIT

Performance Characteristic:

LOAD %	125.0	115.0	100.0	75.0	50.0	25.0	0.0
% EFF	96.31	96.41	96.20	96.20	96.36	95.03	0.00
% PF	88.1	88.5	85.4	81.7	76.2	66.0	23.3
AMPS(460V)	277.3	253.7	230.2	166.6	117.4	75.2	28.9

TORQUE(FL) LB-FT 590.41 TORQUE(LR)%FL 214.0 TORQUE(BD)%FL 288.0
 AMPS(LR 460V) 1450.0 PF AT START 0.23%

Other Useful Information for Application:

Rotor Inertia: Lb-Ft ² (Kg-m ²):	83.06(3.5)
Max load inertia: Lb-Ft ² (Kg-m ²):	831(35.02)
Load Type:	Square Torque/Speed Characteristic
Voltage:	100%
Number of starts per hour:	2 Cold or 1 Hot
Acceleration Time with maximum inertia (sec):	7.2
Safe stall time (sec): Cold/Hot	90/50

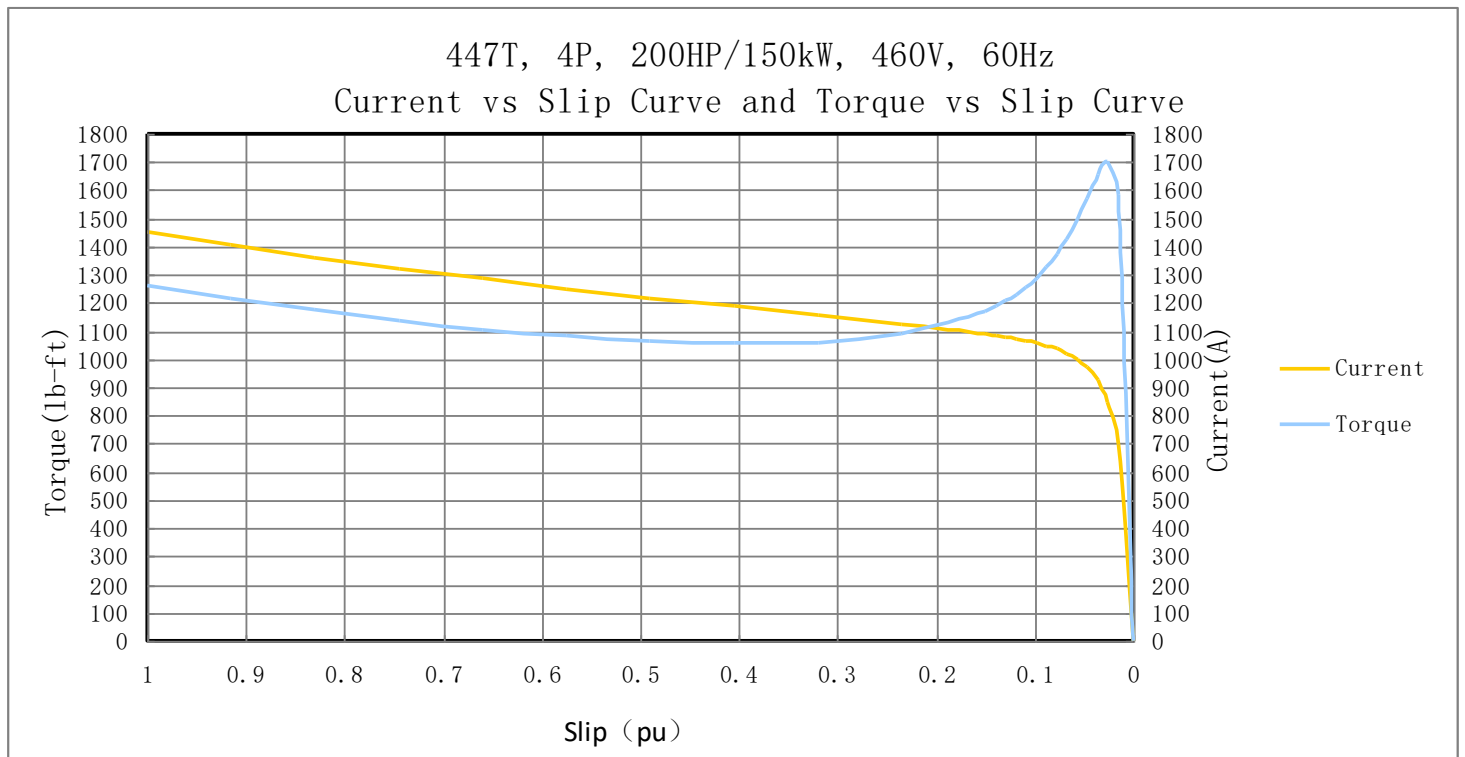

Marks:

- NOTES:
1. CONDUIT BOX IS SUITABLE FOR UP, DOWN OR EITHER SIDE ENTRY.
 2. FL ASSEMBLY AS SHOWN.
 3. ALL DIMENSIONS ARE IN INCHES.

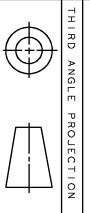
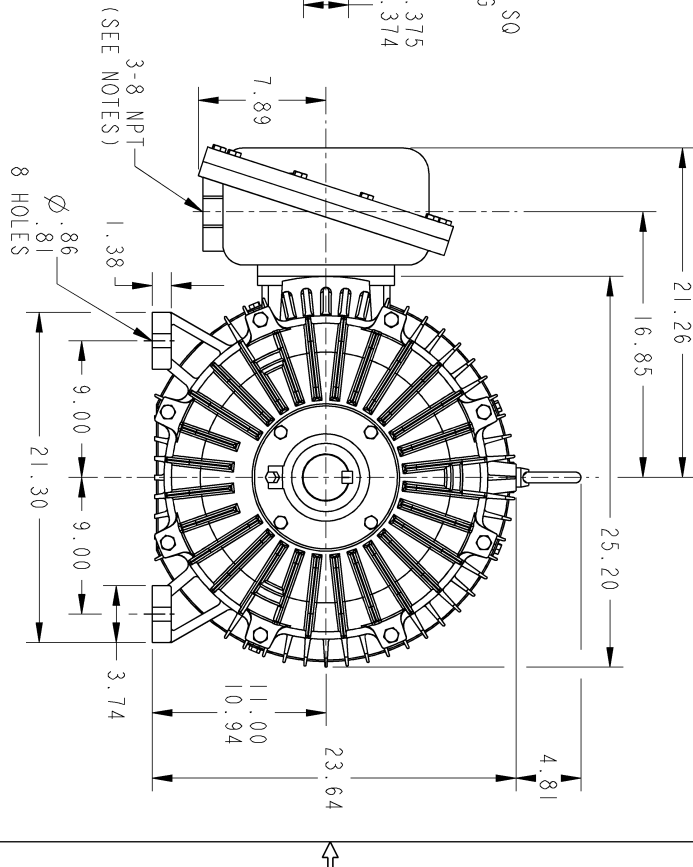
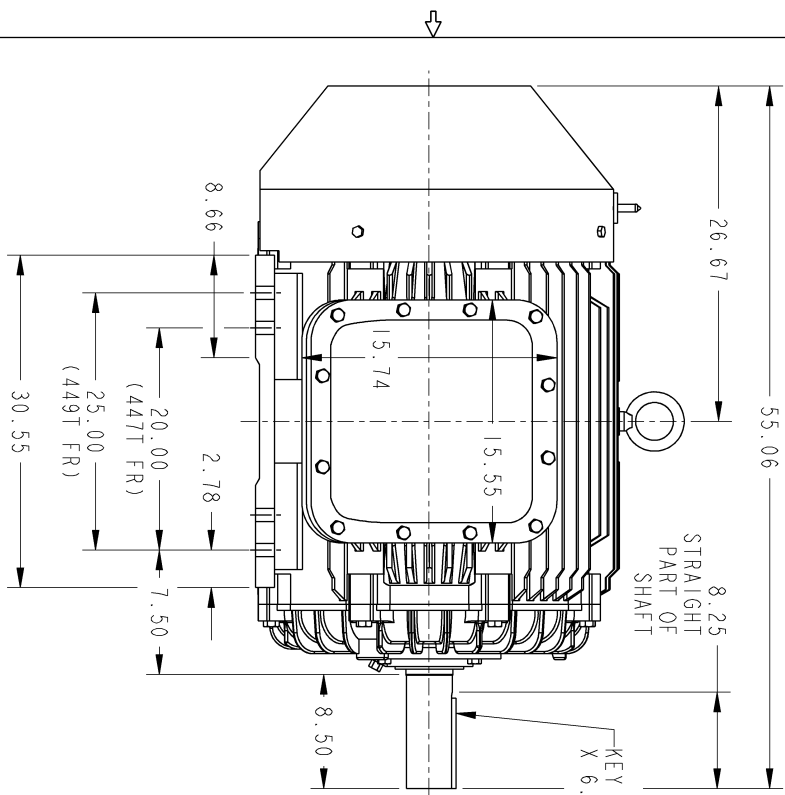

PROPRIETARY INFORMATION
 All rights reserved. This document and the information it contains is the property of the Wabag Electric America LLC and/or its affiliates. It has been provided solely for private use. Copying, reproduction, selling, importing, copying, distribution, or transmission in any form or by any means, electronic or mechanical, including photocopying, recording, or by any information storage and retrieval system, is strictly prohibited except as expressly authorized in writing by the Wabag Electric America LLC.

REV.	DESCRIPTION	DATE	APPROVED
1	ISSAC #17-0780	10/24/17	SRI KANTH
2	ISSAC #18-0869	01/07/19	PRASHANTH
3	ISSAC #19-0358	04/22/19	SAHID

SIGNATURES	DATE
MODEL: MAGARAJ 06/22/17	
DRAWN: SRI KANTH 06/22/17	
CHECKED: SRI KANTH 06/22/17	
ENG'G: SRI KANTH 06/22/17	
QUALITY: SRI KANTH 06/22/17	
ISSUED: SRI KANTH 06/22/17	

GE INDUSTRIAL MOTORS
 a wolong company

TITLE: 447T/449T TERC EXPLOSION PROOF
 901 CU. IN. C/BOX

358B6509AA REV. 003

SCALE: NTS REF. No. SHEET 1 OF 1

Marks:

Connection Diagram
GEM2034E-FIG8

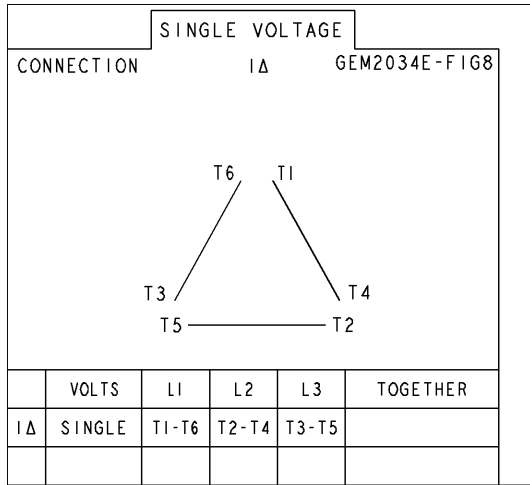

Thermostat Connection
3027JE-2A

