

PRODUCT INFORMATION PACKET

Model No: 143TTDR6313

Catalog No: E783A

General Purpose Motor, 1.50 HP, 3 Ph, 60 Hz, 230/460 V, 3600 RPM, 143T Frame, DP



Regal and are trademarks of Regal Rexnord Corporation or one of its affiliated companies.
©2022 Regal Rexnord Corporation, All Rights Reserved. MC017097E

Nameplate Specifications

Output HP	1.50 Hp	Output KW	1.1 kW
Frequency	60 Hz	Voltage	230/460 V
Current	3.8/1.9 A	Speed	3515 rpm
Service Factor	1.15	Phase	3
Efficiency	86.5 %	Power Factor	84
Duty	Continuous	Insulation Class	F
Design Code	B	KVA Code	L
Frame	143T	Enclosure	Drip Proof
Thermal Protection	No Protection	Ambient Temperature	40 °C
Drive End Bearing Size	6205	Opp Drive End Bearing Size	6203
UL	Recognized	CSA	Y
CE	Y	IP Code	22
Number of Speeds	1		

Technical Specifications

Electrical Type	Squirrel Cage Induction Run	Starting Method	Across The Line
Poles	2	Rotation	Reversible
Resistance Main	9.08 Ohms	Mounting	Rigid Base
Motor Orientation	Horizontal	Drive End Bearing	Ball
Opp Drive End Bearing	Ball	Frame Material	Rolled Steel
Shaft Type	T	Overall Length	12.49 in
Frame Length	8.56 in	Shaft Diameter	0.875 in
Shaft Extension	2.28 in	Assembly/Box Mounting	F1 ONLY
Outline Drawing	A-100085-856	Connection Drawing	A-EE7308

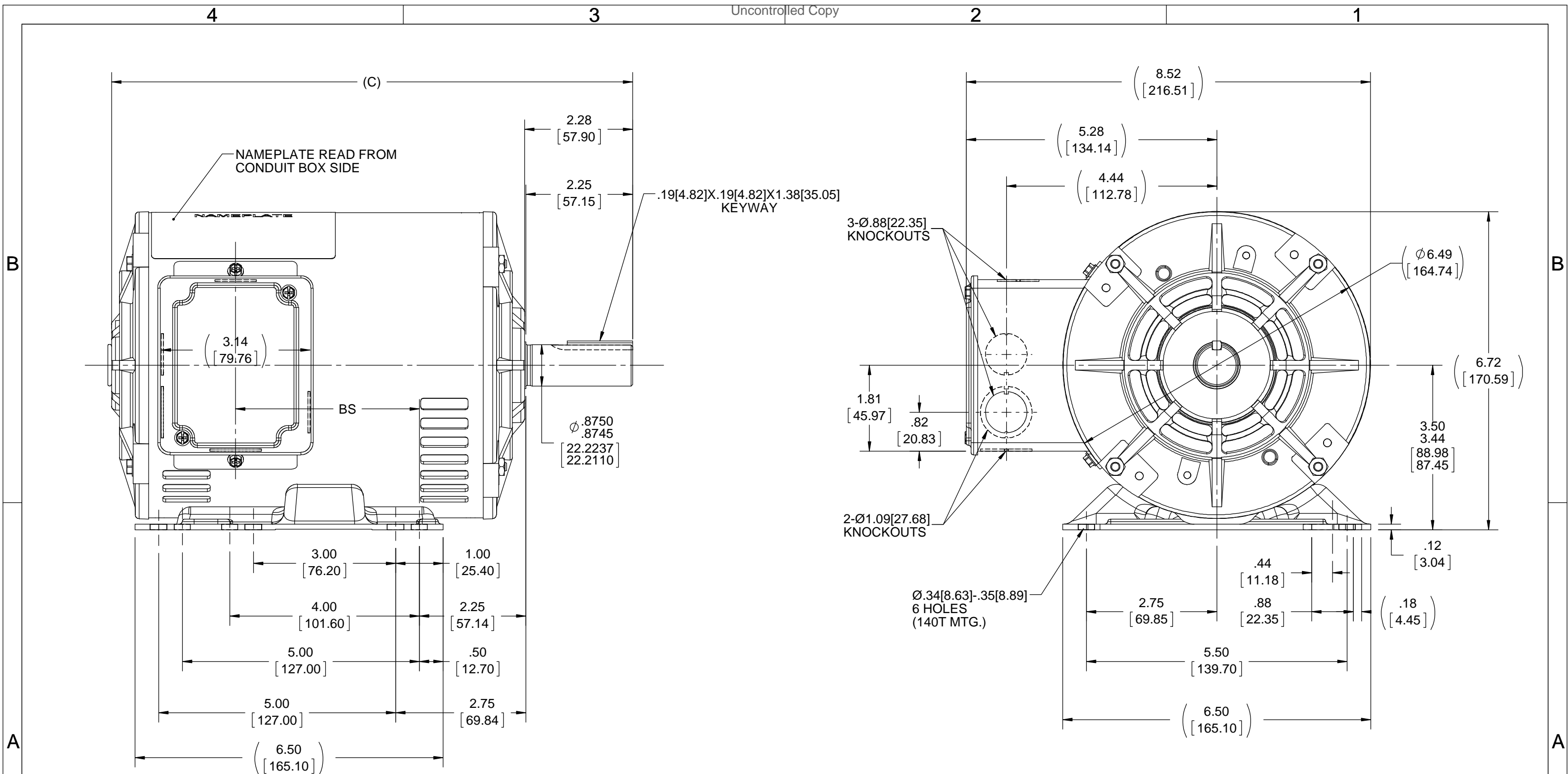

NOTES:
1.CONDUIT BOX CAN BE ROTATED 180°.

DASH NO.	"C"	"BS"
706	10.99[279.14]	3.87[98.29]
756	11.49[291.84]	4.37[110.99]
806	11.99[304.54]	4.87[123.69]
856	12.49[317.24]	5.37[136.39]
906	12.99[329.94]	5.87[149.09]
956	13.49[342.64]	6.37[161.79]

DRAWING REVISION	REVISION BY	DATE
E	A. KEETHA	01-09-2018
ECO-0143026	APPROVED BY PST	DATE 04/11/2018
ECO DESCRIPTION		
OUTLINE CONVERSION PROJECT		
<small>COPYRIGHT REGAL BELOIT AMERICA, INC. ALL RIGHTS RESERVED. PROPRIETARY AND CONFIDENTIAL INFORMATION - THIS DOCUMENT IS THE PROPERTY OF REGAL BELOIT AMERICA, INC. ("OWNER") AND CONTAINS OWNER'S PROPRIETARY INFORMATION. ANY PERSON, CORPORATION OR OTHER FIRM RECEIVING IT IS DEEMED, BY RECEIVING IT, TO AGREE THAT IT, AND/OR ANY PART OF IT, SHALL NOT BE DISCLOSED TO ANY PERSON, CORPORATION OR OTHER ENTITY, DUPLICATED, AND/OR USED, EXCEPT AS EXPRESSLY APPROVED IN WRITING IN ADVANCE BY OWNER. THIS DOCUMENT SHALL BE RETURNED TO OWNER UPON REQUEST. IT MAY BE SUBJECT TO CERTAIN RESTRICTIONS UNDER APPLICABLE EXPORT CONTROL LAWS AND REGULATIONS.</small>		

TOLERANCES UNLESS OTHERWISE SPECIFIED:			
DEC.	INCH	mm	ANGLE
.X	±0.1	[±2.5]	±7° 30'
.XX	±0.03	[±0.76]	
.XXX	±0.005	[±0.127]	
.XXXX	±0.0005	[±0.0127]	
REMOVE BURRS & BREAK SHARP EDGES: .003/.015 [0.076/.381] X 45° CORNER FILLETS: R.02 [0.51]			
MACHINED SURFACES: 200 INCH/mm 5.1			
mm SHOWN IN [BRACKETS]			

DRAWN BY		REGAL™ Regal Beloit America, Inc.	
GK <td colspan="2">DESCRIPTION</td>		DESCRIPTION	
DATE 02-04-1988		OUTLINE	
APPROVED BY FG		140T & 56HZ - DR.PR.	
DATE 02-04-1998		MATERIAL	
REFERENCE 100085		PROCESS/FINISH	
THIRD ANGLE PROJECTION		SIZE DRAWING NUMBER	
B		100085	
		SHEET 1 OF 1	

EE7308

THREE PHASE
DUAL VOLTAGE MOTOR

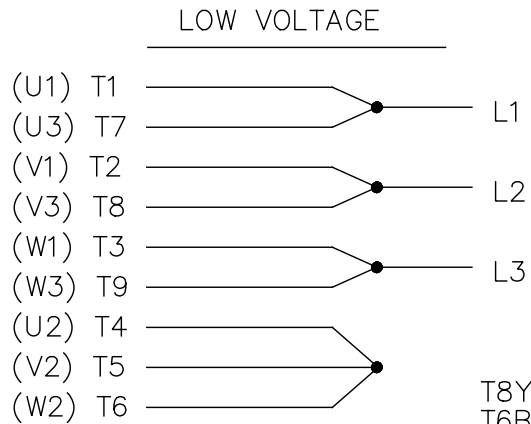
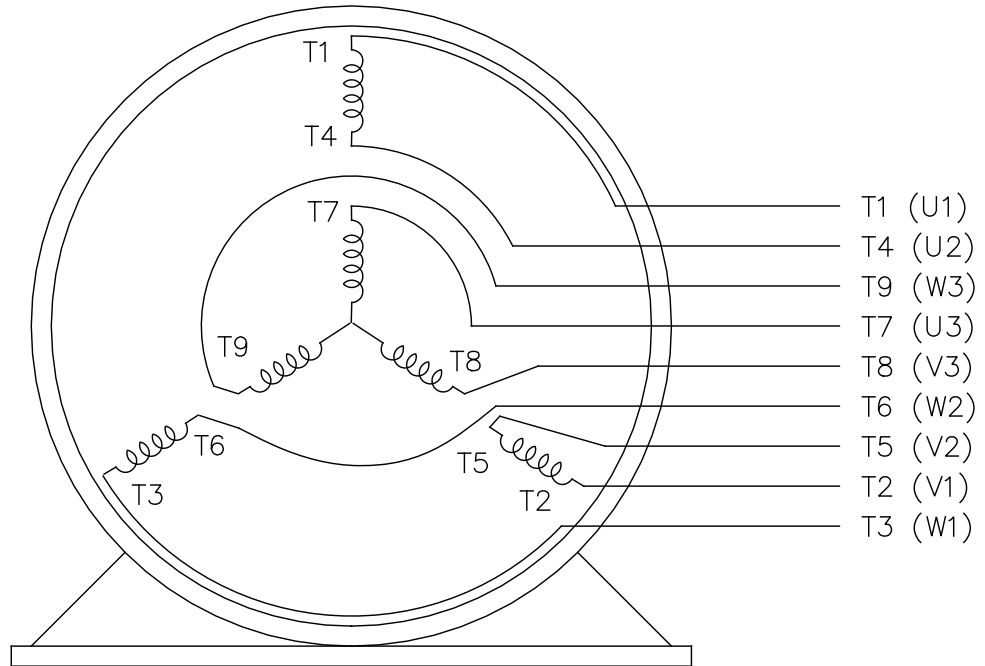
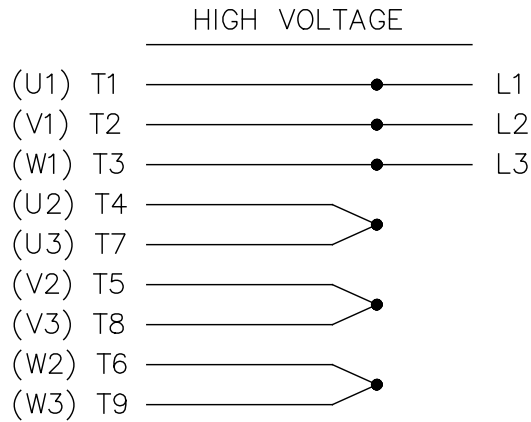

VIEW OF TERMINAL END

REF.
WINDING DIAGRAM

T8Y, T2Y, T2BL, T4BX, T2EC, T2G
T6BZ, T2B, T6BL, T4AV, T6B, T4B

OPTIONAL CORD
CONNECTION

L1 — WHITE
L2 — RED
L3 — BLACK

NO.	REVISION	BY & DATE	CHK	ANG	TOLERANCES UNLESS SPECIFIED		FINISH	DRAWN RM 11/20/1990				
					DEC.	INCHES						
5	CHG TO REGAL LOGO	SL 09/10/2015	AB					CHK ML 11/21/1990				
4	REVISED IEC NOTATIONS	MSG 11/15/2011	CMN	.X	±.1			APPD SAS 04/24/2003				
3	ADDED IEC NOTATIONS... (U1), (V1) ETC. MU95194	MSG 5/10/2010	MJS	.XX	±.02		TITLE CONNECTION DIAGRAM	SCALE 1=1				
2	ADDED THE OPTIONAL CORD CONNECTION MU46318	RDH 04/24/2003	DRS	.XXX	±.005		3Ø - DUAL VOLTAGE MOTOR	REF				
1	REDRAWN	RM 11/20/1990		.XXXX	±.0005		MAT'L.	FMF				
					±7'30"			PREV				
THIS DRAWING IN DESIGN AND DETAIL IS OUR PROPERTY AND MUST NOT BE USED EXCEPT IN CONNECTION WITH OUR WORK ALL RIGHTS OF DESIGN AND INVENTION ARE RESERVED THIS IS AN ELECTRONICALLY GENERATED DOCUMENT - DO NOT SCALE THIS PRINT							RFP	CAD FILE ee7308	SIZE A	DRAWING NO. EE7308	PAGE OF 5	REV. 5
							DIST WP					



Regal Beloit America, Inc.

CERTIFICATION DATA SHEET

Model#: 143TTDR6313 AA
CONN. DIAGRAM: A-EE7308
OUTLINE: A-100085-856

WINDING#: ZT2168 DR 1
ASSEMBLY: F1 ONLY

TYPICAL MOTOR PERFORMANCE DATA

HP	KW	SYNC. RPM	F.L. RPM	FRAME	ENCLOSURE	KVA CODE	DESIGN
1 1/2&1	1.12&.75	3600	3515&2920	143T	DP	L	B

PH	Hz	VOLTS	FL AMPS	START TYPE	DUTY	INSL	S.F	AMB°C	ELEVATION
3	60/50	230/460#190/ 380	3.8/1.9&3.4/1. 7	ACROSS THE LINE	CONTINUOU S	F3	1.15/1.15	40	3300

FULL LOAD EFF: 86.5&86.5	3/4 LOAD EFF: 88.3	1/2 LOAD EFF: 86.6	GTD. EFF	ELEC. TYPE	NO LOAD AMPS
FULL LOAD PF: 84&80.5	3/4 LOAD PF: 78.7	1/2 LOAD PF: 67.6	84	SQ CAGE IND RUN	1.6 / .8

F.L. TORQUE	LOCKED ROTOR AMPS	L.R. TORQUE	B.D. TORQUE	F.L. RISE°C
2.25 LB-FT	37.2 / 18.6	6.8 LB-FT 302	10 LB-FT 444	20

SOUND PRESSURE @ 3 FT.	SOUND POWER	ROTOR WK^2	MAX. WK^2	SAFE STALL TIME	STARTS /HOUR	APPROX. MOTOR WGT
68 dBA	78 dBA	0 LB-FT^2	0 LB-FT^2	10 SEC.	0	0 LBS.

***** SUPPLEMENTAL INFORMATION *****

DE BRACKET TYPE	ODE BRACKET TYPE	MOUNT TYPE	ORIENTATION	SEVERE DUTY	HAZARDOUS LOCATION	DRIP COVER	SCREENS	PAINT
STANDARD	STANDARD	RIGID	HORIZONTAL	FALSE	NONE	FALSE	NONE	BLUE (POWDER)

BEARINGS		GREASE	SHAFT TYPE	SPECIAL DE	SPECIAL ODE	SHAFT MATERIAL	FRAME MATERIAL
DE	OPE						
BALL	BALL	POLYREX EM	T	NONE	NONE	1144 STRESSPROOF (C-223)	ROLLED STEEL
6205	6203						

THERMO-PROTECTORS				THERMISTORS	CONTROL	SPACE /n HEATERS
THERMOSTATS	PROTECTORS	WDG RTDs	BRG RTDs			
NONE	NOT	NONE	NONE	NONE	FALSE	NONE VOLTS

If Inverter equals NONE, contact factory for further information

INVERTER TORQUE: NONE
INV. HP SPEED RANGE: NONE
ENCODER: NONE
NONE NONE
NONE NONE PPR
BRAKE: NONE NONE
NONE P/N NONE
NONE NONE
- FT-LB NONE V NONE Hz

*
N
O
T
E
S
*

DATE: 06/22/2017 07:46:33 AM

FORM 3531 REV.3 02/07/99

** Subject to change without notice.

Data Sheet

Date: 16-06-2017
 Customer: _____
 Attention: _____
 Submitted by: FAREEDA DUDEKULA



143TTDR6313

Submittal

Data @ 460 V

Motor Load Data

Load	0%	25%	50%	75%	100%	115%	125%	LR
Current (Amps)	0.82	0.90	1.20	1.50	1.90	2.20	2.30	18.6
Torque (ft-lb)	0.00	0.55	1.10	1.68	2.25	2.60	2.80	6.8
RPM	3600	3580	3560	3540	3515	3,505	3495	0
Efficiency (%)		79.6	86.6	88.3	86.5	86.6	86.5	
P.F. (%)	14.3	47.2	67.6	78.7	84.0	86.5	87.5	62.5

Motor Speed Data

	LR	Pull-Up	BD	Rated	Idle
Speed (RPM)	0	215	2700	3515	3600
Current (Amps)	18.6	18.7	11.7	1.90	0.82
Torque (ft-lb)	6.8	5.7	10.0	2.25	0.00

Information Block				
HP	1.5			
Sync. RPM	3600			
Frame	143			
Enclosure	DP			
Construction	TDR			
Voltage	230/460#190/38(V)			
Frequency	60 Hz			
Design	A			
LR Code letter	L			
Service Factor	1.15			
Temp Rise @ FL	20 ° C			
Duty	CONT			
Ambient	40 ° C			
Elevation	1,000 feet			
Rotor/Shaft wk ²	0.00 Lb-Ft ²			
Ref Wdg	ZT2168 DR			
Sound Pressure @ 1M	68 dBA			
VFD Rating	NONE			
Outline Dwg	A-100085-856			
Conn. Diag	A-EE7308			
Additional Specifications:				
0				
365THFS8036				
EQUIV CKT (OHMS / PHASE)				
R1	R2	X1	X2	Xm
5.2950	3.7820	9.2660	9.4550	359.2900

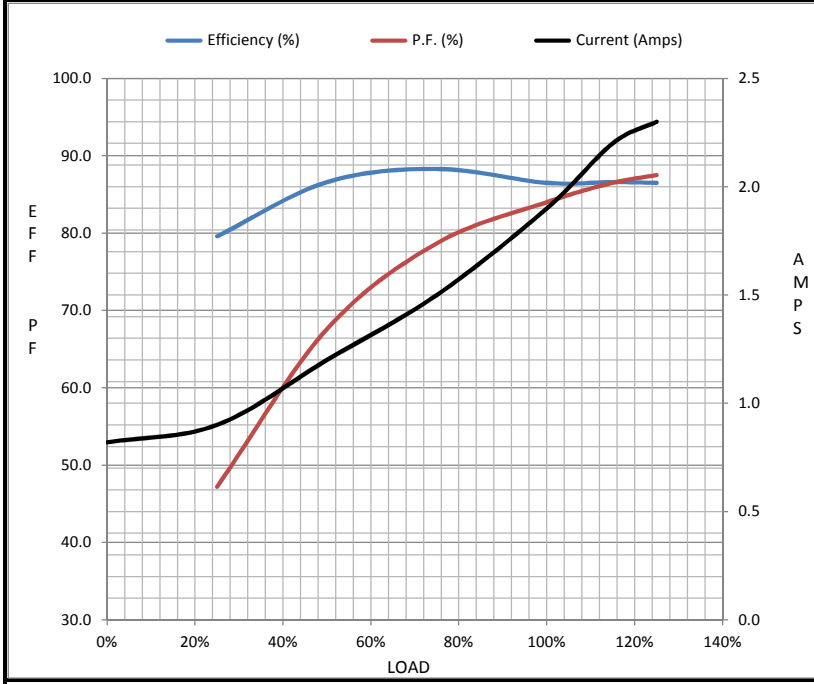

Speed - Torque Curve

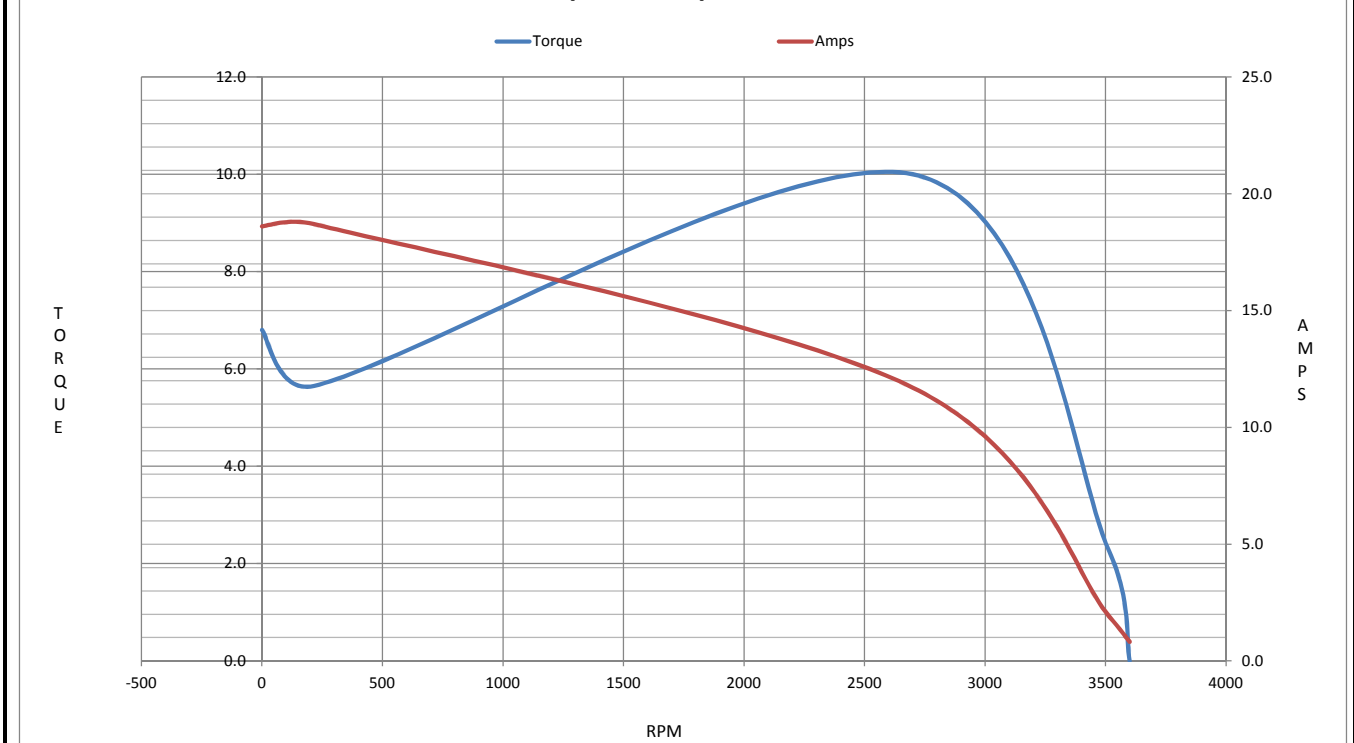

EC Declaration of Conformity

The undersigned representing
the manufacturer:

Regal Beloit America
100 East Randolph St.
Wausau, WI 54401

and the authorized representative
established within the Community:

Marathon Electric UK
6F Thistleton Road Ind. Estate
Market Overton
Oakham, Rutland LE15 7PP UK

are committed to providing customers with products that comply with applicable regulations and international protocols to which they are subject, including the requirements of the European Parliament Directive on the Harmonization of the laws relating to electrical equipment designed for use within certain voltage limits (2014/35/EU).

Regal Beloit America declares that the following product(s), to which this declaration relates, are in conformity with the relevant sections of the EC standards listed below.

This statement supersedes any statements previously issued pertaining to the product(s) listed below and is subject to change without notice.

Model No : 143TTDR6313

(Model No. may contain prefix and/or suffix characters)

Catalog No : E783A

Rework No : N/A

Directives :

Low Voltage Directive 2014/35/EU

Harmonized Standards Used :

EN 60034-1: 2010 (IEC 60034-1: 2010)

EN 60034-5: 2001/A1:2007 (IEC 60034-5: 2000/A1:2006)

Authorized Representative:



Michael A. Logsdon
Vice President, Technology

Authorized Representative in the Community:



Julian Clark
Marketing Engineer

Created on 09/01/2022

CE 22