

BALDOR® • RELIANCE 

Product Information Packet

ECP2276T-4

7.5HP, 1180RPM, 3PH, 60HZ, 254T, 0954M, TEFC, F

Part Detail							
Revision:	AT	Status:	PRD/A	Change #:		Proprietary:	No
Type:	AC	Elec. Spec:	09WGY237	CD Diagram:	CD0006	Mfg Plant:	
Mech. Spec:	09J371	Layout:	09LYJ371	Poles:	06	Created Date:	08-29-2010
Base:	RG	Eff. Date:	04-05-2022	Leads:	3#12		

Specs			
Catalog Number:	ECP2276T-4	Inverter Code:	Inverter Duty
Enclosure:	TEFC	KVA Code:	J
Frame:	254T	Lifting Lugs:	Standard Lifting Lugs
Frame Material:	Iron	Locked Bearing Indicator:	Locked Bearing
Output @ Frequency:	7.500 HP @ 60 HZ	Motor Lead Quantity/Wire Size:	3 @ 12 AWG
Synchronous Speed @ Frequency:	1200 RPM @ 60 HZ	Motor Lead Exit:	Ko Box
Voltage @ Frequency:	460.0 V @ 60 HZ	Motor Lead Termination:	Flying Leads
XP Class and Group:	CLI GP A,B,C,D	Motor Type:	0954M
XP Division:	Division II	Mounting Arrangement:	F1
Agency Approvals:	UR	Power Factor:	71
	CSA EEV	Product Family:	Super-E Chemical Processing
	CSA	Pulley End Bearing Type:	Ball
Auxillary Box:	No Auxillary Box	Pulley Face Code:	Standard
Auxillary Box Lead Termination:	None	Pulley Shaft Indicator:	Standard
Base Indicator:	Rigid	Rodent Screen:	None
Bearing Grease Type:	Polyrex EM (-20F +300F)	Shaft Extension Location:	Pulley End
Blower:	None	Shaft Ground Indicator:	No Shaft Grounding
Constant Torque Speed Range:	1.0	Shaft Rotation:	Reversible

Current @ Voltage:	10.700 A @ 460.0 V	Shaft Slinger Indicator:	Shaft Slinger
Design Code:	A	Speed Code:	Single Speed
Drip Cover:	No Drip Cover	Motor Standards:	NEMA
Duty Rating:	CONT	Starting Method:	Direct on line
Electrically Isolated Bearing:	Not Electrically Isolated	Thermal Device - Bearing:	None
Feedback Device:	NO FEEDBACK	Thermal Device - Winding:	None
Front Face Code:	Standard	Vibration Sensor Indicator:	No Vibration Sensor
Front Shaft Indicator:	None	Winding Thermal 1:	None
Heater Indicator:	No Heater	Winding Thermal 2:	None
Insulation Class:	F	XP Temp Code:	T3C

Nameplate NP3995ABBL												
CAT # ECP2276T-4			SER			CC 010A						
SPEC 09J371Y237			RATING 40C AMB-CONT									
HZ	VOLTS		AMPS		RPM	HP	CODE	SF	DES	PF	NEMA NOM. EFF	
60	460		10.7		1180	7.5	J	1.15	A	71 %	91 %	
										%	%	
PH 3	CL F	MAX RPM 1800		MAX CORR KVAR 4.1		USABLE AT 208V						
IP55	FR 254T	ENCL TEFC		DE BRG 6309		ODE BRG 6309						
GREASE POLYREX EM						MTR WT 302		LBS				
USABLE AT 50HZ 5HP 380V 9.3A						SF1.0						
CL I DIV 2 GRPS A,B,C,D						CL I ZONE 2 GRPS			IIA,IIB,IIC			TEMP T 160 C
1.0 SF ON PWM INVERTER			POWER			INV TEMP CL 180 C						
CHP 60-90	HZ 1.5:1	CT 1.0-60		HZ 60:1			VT 0-60		HZ 1000:1			
SPACE HEATER LEADS H1-H2:						TIE LIKE NUMBERS			TOGETHER			
V	A	W		MAX SPACE HEATER TEMP								

Parts List		
Part Number	Description	Quantity
SA202250	SA 09J371Y237	1.000 EA
RA189531	RA 09J371Y237	1.000 EA
09FN3001D01SP	EXTERNAL FAN, PLASTIC (COMES W/SCREW FRO	1.000 EA
09CB1002A12P	KOBX W/1.25 NPT LEAD HOLE & 2.38 MTG HOL	1.000 EA
09GS1010	GASKET, DWG, LEADWIRE SEPERATOR	1.000 EA
51XW2520A12	.25-20 X .75, TAPTITE II, HEX WSHR SLTD	4.000 EA
WD1000B16	T&B CX70TN OR L70P TERMINAL LUG	1.000 EA
10XN2520K08	1/4-20 X .50 GRADE #5, STL, ZINC PLATE	1.000 EA
HW1001A25	LOCKWASHER 1/4, ZINC PLT .493 OD, .255 I	1.000 EA
HA3400A39	STUD- 3/8-16 X 6.44 OAL HEX	4.000 EA
HW1001A38	LOCKWASHER 3/8, ZINC PLT .688 OD, .382 I	4.000 EA
HW4600B44	V-RING SLINGER 1.500 X 1.810 X .28 VITON	1.000 EA
HW4600B44	V-RING SLINGER 1.500 X 1.810 X .28 VITON	1.000 EA
HA4017A08	.125X3.50 GREASER EXTEN.	1.000 EA
HA4017A02	.125X2.50 GREASER EXTENS.F/S	1.000 EA
HW4019A01	PIPE COUPLING 1/8 NPT,STEEL,ZINC COATING	1.000 EA
HW4500A20	1/8NPT SL PIPE PLUG	1.000 EA
HW5100A11	W3917-042 WVY WSHR (WB)	1.000 EA
10XN2520K36	1/4-20 X 2.25" HX HD SCRWGRADE 5, ZINC P	4.000 EA
09FH1000P	FAN COVER, CAST W/EPOXY PRIMER	1.000 EA
09EP1118A38P	PUEP MACH,309 BRG,PLS GRSR,RLF,EPOXY PRI	1.000 EA
10XN3816K28	3/8-16 X 1.75 HEX HD CAP SCREW, GRADE 5	4.000 EA
HW1001A38	LOCKWASHER 3/8, ZINC PLT .688 OD, .382 I	4.000 EA
HW4500A20	1/8NPT SL PIPE PLUG	1.000 EA

Parts List (continued)		
Part Number	Description	Quantity
10XN2520K36	1/4-20 X 2.25" HX HD SCRWGRADE 5, ZINC P	4.000 EA
HW1001A38	LOCKWASHER 3/8, ZINC PLT .688 OD, .382 I	4.000 EA
XY3816A12	3/8-16 FINISHED NUT	4.000 EA
12CB1503P	CONDUIT BOX LID, CAST W/EPOXY PRIMER	1.000 EA
12GS1002	GASKET, CONDUIT BOX LID, NEOP	1.000 EA
10XN3118K16	5/16-18 X 1' GRADE #5, STL, ZINC PLATE	2.000 EA
HW1001A31	LOCKWASHER 5/16, ZINC PLT.591 OD, .319 I	2.000 EA
HW2501G25	KEY, 3/8 SQ X 2.875	1.000 EA
MJ5001A27	32220KN GRAY SEALER *MIN BUY 4 QTS=1GAL	0.031 QT
MJ5002A01	SILICON RUBBER SEALANT, 732CL 10.3 OZ TU	0.033 EA
09EP1118A37LP5	FREP MACH, 309 BRG. EPOXY PRIMER	1.000 EA
MJ5002A01	SILICON RUBBER SEALANT, 732CL 10.3 OZ TU	0.025 EA
85XU0407S04	4X1/4 U DRIVE PIN STAINLESS	2.000 EA
LB1115N	LABEL,LIFTING DEVICE (ON ROLLS)	1.000 EA
MN416A01	TAG-INSTAL-MAINT no wire (2100/bx) 4/22	1.000 EA
NP3995ABBL	SS SUPER-E SD XEX CLI DIV2 UR CSA-C-US E	1.000 EA
HW4500A17	317400 ALEMITE GREASE RELIEF	1.000 EA
HW4500A21	1618BALEMITE FITTING 825 UNIVERSAL	1.000 EA
HA4054	SHORT T-DRAIN FITTING, .125" N.P.T.	1.000 EA
HA4051A00	PLASTIC CAP FOR GREASE FITTING	1.000 EA
MJ1000A02	GREASE, MOBIL POLYREX EM - 124047	0.080 LB
HW4500A03	GREASE FITTING, .125 NPT 1610(ALEMITE) 8	1.000 EA
HW4500A17	317400 ALEMITE GREASE RELIEF	1.000 EA
HA4054	SHORT T-DRAIN FITTING, .125" N.P.T.	1.000 EA

Product Information Packet: ECP2276T-4 - 7.5HP,1180RPM,3PH,60HZ,254T,0954M,TEFC,F

HA4051A00	PLASTIC CAP FOR GREASE FITTING	1.000 EA
HW2500A25	WOODRUFF KEY USA #1008 #BLOW CARBON STEE	1.000 EA
MG1025N19	WILKOFASST, 778.50, RELIANCE BLUE-GREEN	0.050 GA
40PA1005	PACKAGING GROUP, 09 STD	1.000 EA
LD7020D03	LEAD SET, 12AWG, 3 LEAD, 20" LONG LEADS	1.000 EA

Accessories		
Part Number	Description	Multiplier
09-1309	C FACE KIT	A8
RB3001A01	MACH RETAINER RING 309/211 BRG	

AC Induction Motor Performance Data

Record # 47267

Typical performance - not guaranteed values

Winding: 09WGY237-R028		Type: 0954M		Enclosure: TEFC	
Nameplate Data			460 V, 60 Hz: Single Voltage Motor		
Rated Output (HP)	7.5	Full Load Torque	33.3 LB-FT		
Volts	460	Start Configuration	direct on line		
Full Load Amps	10.7	Breakdown Torque	99.5 LB-FT		
R.P.M.	1180	Pull-up Torque	39.7 LB-FT		
Hz	60 Phase	3	Locked-rotor Torque	58.4 LB-FT	
NEMA Design Code	B	KVA Code	J	Starting Current	70.1 A
Service Factor (S.F.)	1.15		No-load Current	5.52 A	
NEMA Nom. Eff.	91	Power Factor	71	Line-line Res. @ 25°C	0.895 Ω
Rating - Duty	40C AMB-CONT		Temp. Rise @ Rated Load	32°C	
S.F. Amps			Temp. Rise @ S.F. Load	42°C	
			Rotor inertia	4.34 LB-FT ²	

Load Characteristics 460 V, 60 Hz, 7.5 HP

% of Rated Load	25	50	75	100	125	150	S.F.
Power Factor	33	53	65	71	74	75	73
Efficiency	84.9	90.6	91.8	91.4	91.4	90.5	91.6
Speed	1196	1192	1188	1183	1178	1173	1180
Line amperes	6.25	7.28	8.82	10.72	12.91	15.5	12.03

Performance Graph at 460V, 60Hz, 7.5HP Typical performance - Not guaranteed values

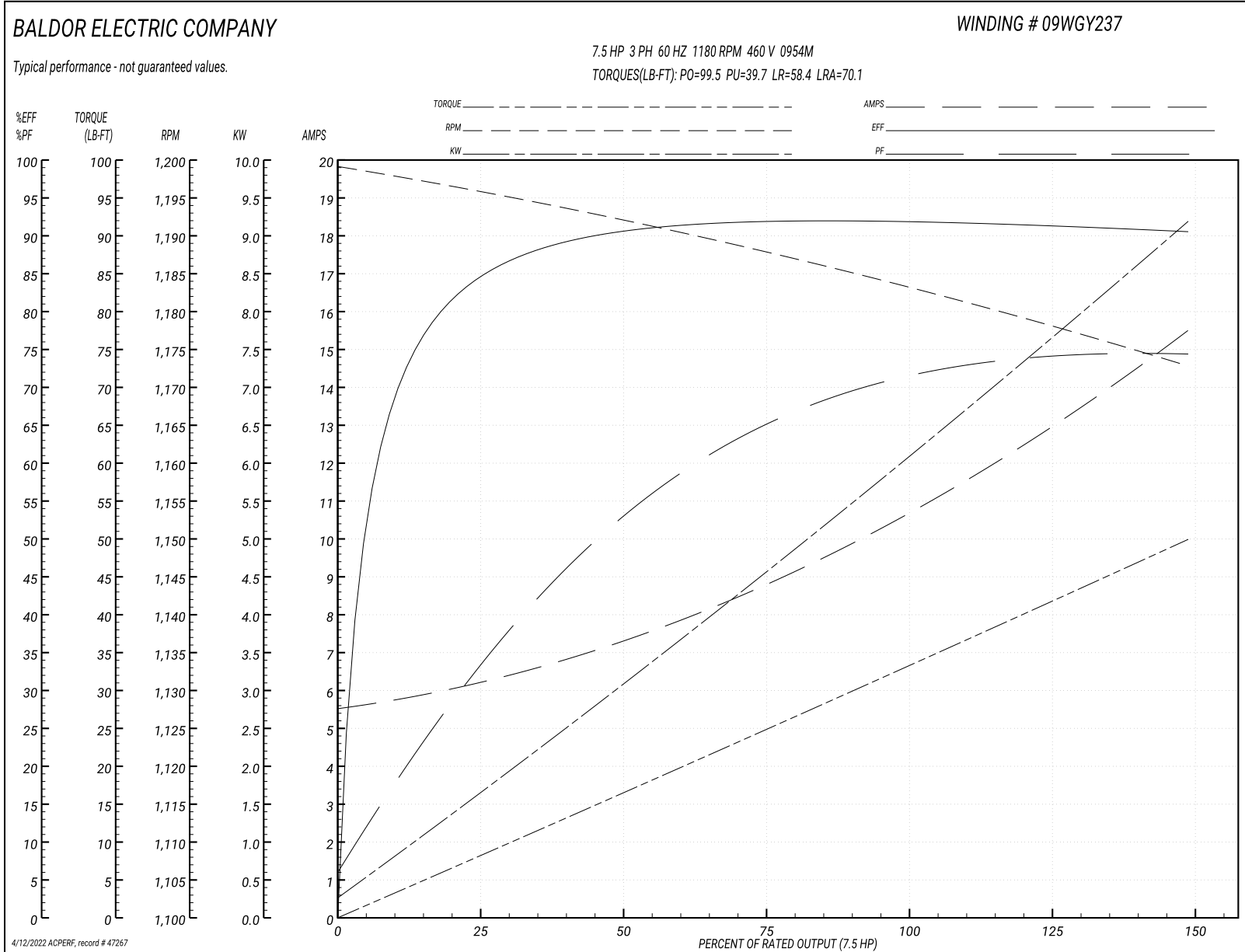

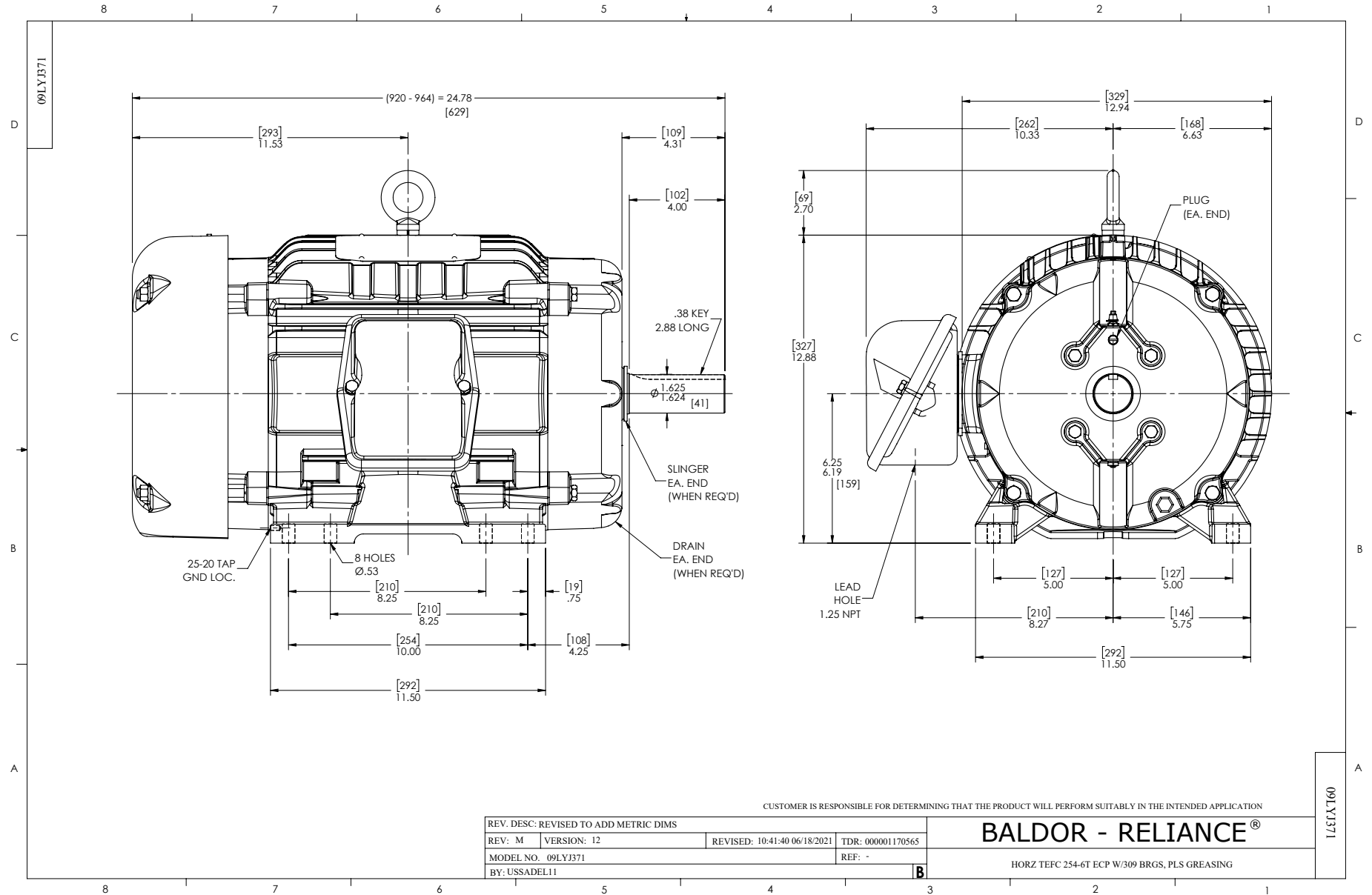

CD0006

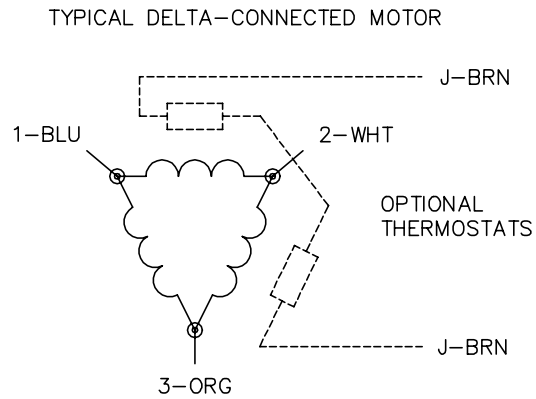
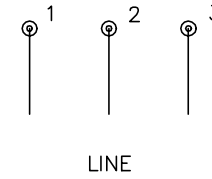
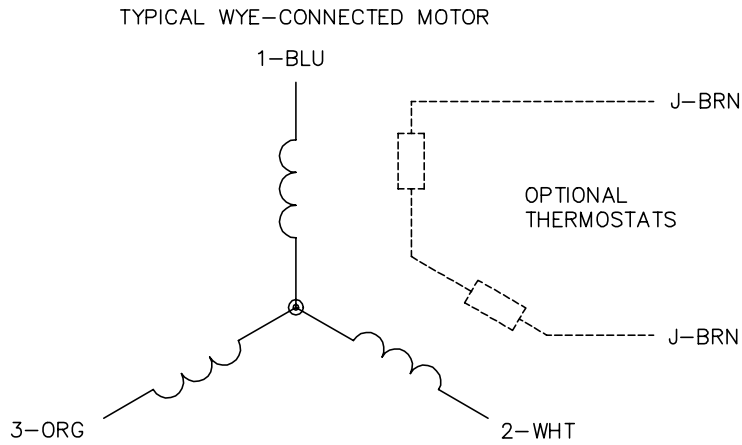

NOTES:

1. THREE LEAD MOTOR MAY BE EITHER WYE CONNECTED OR DELTA CONNECTED.
2. INTERCHANGE ANY TWO LINE LEADS TO REVERSE ROTATION.
3. OPTIONAL THERMOSTATS ARE PROVIDED WHEN SPECIFIED.
4. ACTUAL NUMBER OF INTERNAL PARALLEL CIRCUITS MAY VARY.
5. LEAD COLORS ARE OPTIONAL. LEADS MUST BE NUMBERED AS SHOWN.

CD0006

REV. DESC: ADD CLASS CONN00000007		
REV. LTR: E	VERSION: 01	TDR: 000001099922
FILE: \AAA\00005\141	REVISED: 10:24:49 02/19/2019	BY: ENBRIRO
MTL: -	© □	

BALDOR - RELIANCE®

3PH, SV, 3 LEADS, WYE OR DELTA CONNECTED

SH 1 of 1

Marketing maintained PDF of MN416:

<http://www.baldor.com/support/Literature/Load.ashx/MN416?ManNumber=MN416>