

BALDOR® • RELIANCE 

Product Information Packet

ECP2294T

30M 2P TEFC HOR 254T CHEM SERV SP32-6 SE

Part Detail							
Revision:	H	Status:	PRD/A	Change #:		Proprietary:	No
Type:	AC	Elec. Spec:	09WGZ602	CD Diagram:	CD0180	Mfg Plant:	
Mech. Spec:	09J371	Layout:	09LYJ371	Poles:	02	Created Date:	05-29-2018
Base:	RG	Eff. Date:	04-05-2022	Leads:	9#12		

Specs			
Catalog Number:	ECP2294T	Heater Indicator:	No Heater
Enclosure:	TEFC	Insulation Class:	F
Frame:	254T	Inverter Code:	Inverter Duty
Frame Material:	Iron	KVA Code:	G
Output @ Frequency:	15.000 HP @ 60 HZ	Lifting Lugs:	Standard Lifting Lugs
Synchronous Speed @ Frequency:	3600 RPM @ 60 HZ	Locked Bearing Indicator:	Locked Bearing
Voltage @ Frequency:	460.0 V @ 60 HZ	Motor Lead Quantity/Wire Size:	9 @ 12 AWG
	230.0 V @ 60 HZ	Motor Lead Exit:	Ko Box
XP Class and Group:	CLI GP A,B,C,D	Motor Lead Termination:	Flying Leads
XP Division:	Division II	Motor Type:	0930M
Agency Approvals:	CCSA US	Mounting Arrangement:	F1
	CSA	Power Factor:	87
	CSA EEV	Product Family:	Super-E Chemical Processing
	UR	Pulley End Bearing Type:	Ball
Auxillary Box:	No Auxillary Box	Pulley Face Code:	Standard
Auxillary Box Lead Termination:	None	Pulley Shaft Indicator:	Standard
Base Indicator:	Rigid	Rodent Screen:	None
Bearing Grease Type:	Polyrex EM (-20F +300F)	Shaft Extension Location:	Pulley End

Blower:	None	Shaft Ground Indicator:	No Shaft Grounding
Constant Torque Speed Range:	6	Shaft Rotation:	Reversible
Current @ Voltage:	38.000 A @ 208.0 V	Shaft Slinger Indicator:	Shaft Slinger
	35.000 A @ 230.0 V	Speed Code:	Single Speed
	17.500 A @ 460.0 V	Motor Standards:	NEMA
Design Code:	B	Starting Method:	Direct on line
Drip Cover:	No Drip Cover	Thermal Device - Bearing:	None
Duty Rating:	CONT	Thermal Device - Winding:	None
Electrically Isolated Bearing:	Not Electrically Isolated	Vibration Sensor Indicator:	No Vibration Sensor
Feedback Device:	NO FEEDBACK	Winding Thermal 1:	None
Front Face Code:	Standard	Winding Thermal 2:	None
Front Shaft Indicator:	None	XP Temp Code:	T3C

Nameplate NP3995ABEL											
CAT # ECP2294T			SER			CC 010A					
SPEC 09J371Z602G2			RATING 40C AMB-CONT								
HZ	VOLTS		AMPS		RPM	HP	CODE	SF	DES	PF	NEMA NOM. EFF
60	230/460		35/17.5		3520	15	G	1.15	B	87 %	91 %
										%	%
PH 3	CL F	MAX RPM 5400		MAX CORR KVAR 2.85		USABLE AT 208V		38			
IP55	FR 254T	ENCL TEFC		DE BRG 6309		ODE BRG 6309					
GREASE POLYREX EM						MTR WT 253		LBS			
USABLE AT 50HZ 10HP 190/380V 29.4/14.7A											
CL I DIV 2 GRPS A,B,C,D				CL I ZONE 2 GRPS				IIA,IIB,IIC		TEMP T 160 C	
1.0 SF ON PWM INVERTER				POWER		INV TEMP CL 180 C					
CHP 60-90	HZ 1.5:1		CT 6-60		HZ 10:1		VT 3-60		HZ 20:1		
SPACE HEATER LEADS H1-H2:											
V	A	W		TIE LIKE NUMBERS				TOGETHER			
MAX SPACE HEATER TEMP											

Parts List		
Part Number	Description	Quantity
SA356360	SA 09J371Z602G2	1.000 EA
RA345306	RA 09J371Z602G2	1.000 EA
37FN3002C02	EXFN, PLASTIC, 6.00 OD, 1.503 ID	1.000 EA
09CB1002A12P	KOBX W/1.25 NPT LEAD HOLE & 2.38 MTG HOL	1.000 EA
09GS1010	GASKET, DWG, LEADWIRE SEPERATOR	1.000 EA
51XW2520A12	.25-20 X .75, TAPTITE II, HEX WSHR SLTD	4.000 EA
WD1000B16	T&B CX70TN OR L70P TERMINAL LUG	1.000 EA
10XN2520K08	1/4-20 X .50 GRADE #5, STL, ZINC PLATE	1.000 EA
HW1001A25	LOCKWASHER 1/4, ZINC PLT .493 OD, .255 I	1.000 EA
HA3400A39	STUD- 3/8-16 X 6.44 OAL HEX	4.000 EA
HW1001A38	LOCKWASHER 3/8, ZINC PLT .688 OD, .382 I	4.000 EA
HW4600B44	V-RING SLINGER 1.500 X 1.810 X .28 VITON	1.000 EA
HA4017A08	.125X3.50 GREASER EXTEN.	1.000 EA
HA4017A02	.125X2.50 GREASER EXTENS.F/S	1.000 EA
HW4019A01	PIPE COUPLING 1/8 NPT,STEEL,ZINC COATING	1.000 EA
HW4500A20	1/8NPT SL PIPE PLUG	1.000 EA
HW5100A11	W3917-042 WVY WSHR (WB)	1.000 EA
10XN2520K36	1/4-20 X 2.25" HX HD SCRWGRADE 5, ZINC P	4.000 EA
09EP1118A38P	PUEP MACH,309 BRG,PLS GRSR,RLF,EPOXY PRI	1.000 EA
10XN3816K28	3/8-16 X 1.75 HEX HD CAP SCREW, GRADE 5	4.000 EA
HW1001A38	LOCKWASHER 3/8, ZINC PLT .688 OD, .382 I	4.000 EA
HW4600B44	V-RING SLINGER 1.500 X 1.810 X .28 VITON	1.000 EA
HW4500A20	1/8NPT SL PIPE PLUG	1.000 EA
10XN2520K36	1/4-20 X 2.25" HX HD SCRWGRADE 5, ZINC P	4.000 EA

Parts List (continued)		
Part Number	Description	Quantity
09FH1000P	FAN COVER, CAST W/EPOXY PRIMER	1.000 EA
HW1001A38	LOCKWASHER 3/8, ZINC PLT .688 OD, .382 I	4.000 EA
XY3816A12	3/8-16 FINISHED NUT	4.000 EA
12CB1503P	CONDUIT BOX LID, CAST W/EPOXY PRIMER	1.000 EA
12GS1002	GASKET, CONDUIT BOX LID, NEOP	1.000 EA
10XN3118K16	5/16-18 X 1' GRADE #5, STL, ZINC PLATE	2.000 EA
HW1001A31	LOCKWASHER 5/16, ZINC PLT.591 OD, .319 I	2.000 EA
HW2501G25	KEY, 3/8 SQ X 2.875	1.000 EA
MJ5001A27	32220KN GRAY SEALER *MIN BUY 4 QTS=1GAL	0.031 QT
MJ5002A01	SILICON RUBBER SEALANT, 732CL 10.3 OZ TU	0.033 EA
09EP1118A37LP5	FREP MACH, 309 BRG. EPOXY PRIMER	1.000 EA
HW4500A17	317400 ALEMITE GREASE RELIEF	1.000 EA
HW4500A21	1618BALEMITE FITTING 825 UNIVERSAL	1.000 EA
HA4054	SHORT T-DRAIN FITTING, .125" N.P.T.	1.000 EA
HA4051A00	PLASTIC CAP FOR GREASE FITTING	1.000 EA
MJ1000A02	GREASE, MOBIL POLYREX EM - 124047	0.080 LB
HW4500A03	GREASE FITTING, .125 NPT 1610(ALEMITE) 8	1.000 EA
HW4500A17	317400 ALEMITE GREASE RELIEF	1.000 EA
HA4054	SHORT T-DRAIN FITTING, .125" N.P.T.	1.000 EA
HA4051A00	PLASTIC CAP FOR GREASE FITTING	1.000 EA
HW2500A25	WOODRUFF KEY USA #1008 #BLOW CARBON STEE	1.000 EA
MG1025N19	WILKOFASST, 778.50, RELIANCE BLUE-GREEN	0.050 GA
MJ5002A01	SILICON RUBBER SEALANT, 732CL 10.3 OZ TU	0.025 EA
85XU0407S04	4X1/4 U DRIVE PIN STAINLESS	2.000 EA

Product Information Packet: ECP2294T - 30M 2P TEFC HOR 254T CHEM SERV SP32-6 SE

LB1115N	LABEL,LIFTING DEVICE (ON ROLLS)	1.000 EA
MN416A01	TAG-INSTAL-MAINT no wire (2100/bx) 4/22	1.000 EA
NP3995ABEL	SS SUPER-E SD XEX CLI DIV2 UR CSA-C-US E	1.000 EA
40PA1005	PACKAGING GROUP, 09 STD	1.000 EA
LD7020D09	LEAD SET, 12AWG, 9 LEAD, 20" LONG LEADS	1.000 EA

AC Induction Motor Performance Data

Record # 70995

Typical performance - not guaranteed values

Winding: 09WGZ602-R050			Type: 0930M			Enclosure: TEFC		
Nameplate Data				460 V, 60 Hz: High Voltage Connection				
Rated Output (HP)	15		Full Load Torque	22.1 LB-FT				
Volts	230/460		Start Configuration	direct on line				
Full Load Amps	35/17.5		Breakdown Torque	105 LB-FT				
R.P.M.	3520		Pull-up Torque	26.2 LB-FT				
Hz	60 Phase	3	Locked-rotor Torque	36.3 LB-FT				
NEMA Design Code	B KVA Code	G	Starting Current	110 A				
Service Factor (S.F.)	1.15		No-load Current	5.58 A				
NEMA Nom. Eff.	91 Power Factor	87	Line-line Res. @ 25°C	0.68654 Ω				
Rating - Duty	40C AMB-CONT		Temp. Rise @ Rated Load	63°C				
S.F. Amps			Temp. Rise @ S.F. Load	78°C				
			Locked-rotor Power Factor	30				
			Rotor inertia	0.766 LB-FT ²				

Load Characteristics 460 V, 60 Hz, 15 HP

% of Rated Load	25	50	75	100	125	150	S.F.
Power Factor	55	77	85	87	89	89	88
Efficiency	86.4	91	91.6	91	90	88.6	90.4
Speed	3582.7	3563.6	3542.7	3520.9	3495.8	3468.3	3506
Line amperes	6.93	9.78	13.5	17.5	21.6	26.4	20

Performance Graph at 460V, 60Hz, 15.0HP Typical performance - Not guaranteed values

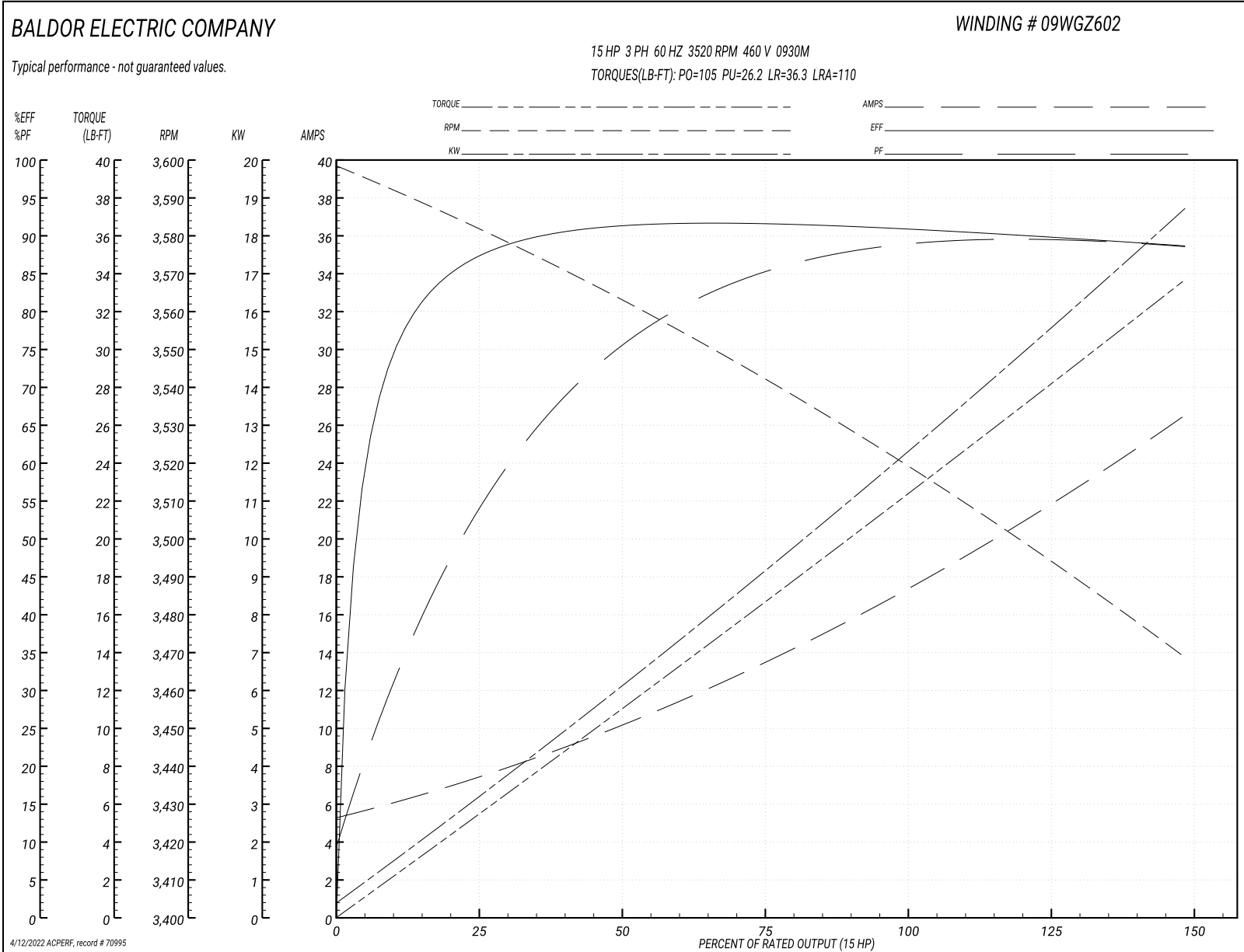

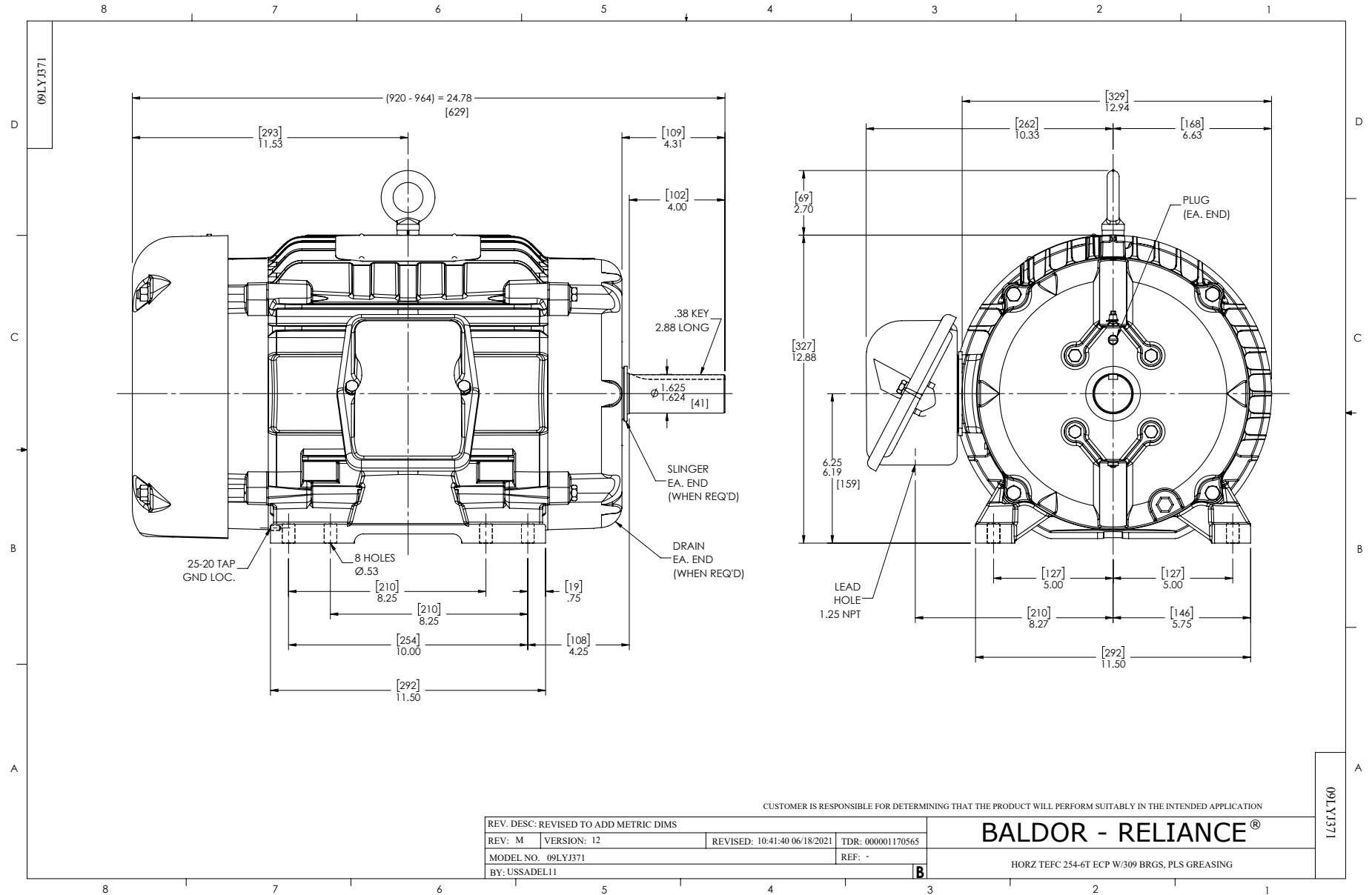

CD0180

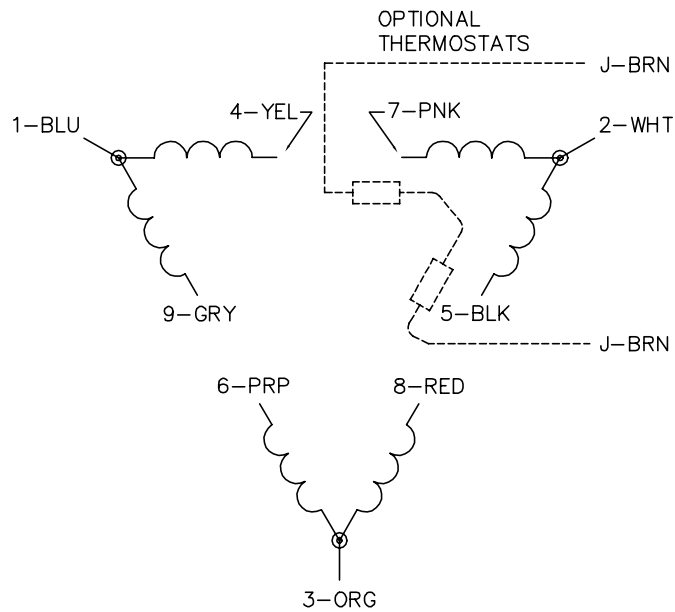

LOW VOLTAGE
(2D)

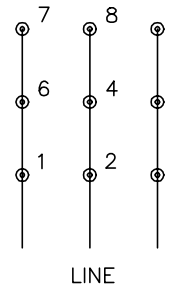

HIGH VOLTAGE
(1D)

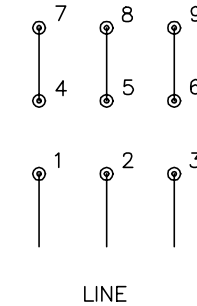

NOTES:

1. INTERCHANGE ANY TWO LINE LEADS TO REVERSE ROTATION.
2. OPTIONAL THERMOSTATS ARE PROVIDED WHEN SPECIFIED.
3. ACTUAL NUMBER OF INTERNAL PARALLEL CIRCUITS MAY BE A MULTIPLE OF THOSE SHOWN ABOVE.
4. LEAD COLORS ARE OPTIONAL. LEADS MUST ALWAYS BE NUMBERED AS SHOWN.

CD0180

REV. DESC: ADD CLASS CONN00000007		
REV. LTR: D	VERSION: 01	TDR: 000001099922
FILE: \AAA\00005\148	REVISED: 10:25:29 02/19/2019	BY: ENBRIRO
MTL: -	© □	

BALDOR - RELIANCE®

3PH, DV, 9 LEADS, DELTA CONNECTION

SH 1 of 1

Marketing maintained PDF of MN416:

<http://www.baldor.com/support/Literature/Load.ashx/MN416?ManNumber=MN416>