

BALDOR® • RELIANCE 

Product Information Packet

ECP4109T-4

40HP,3540RPM,3PH,60HZ,324TS,1244M,TEFC,F

Part Detail							
Revision:	K	Status:	PRD/A	Change #:		Proprietary:	No
Type:	AC	Elec. Spec:	12WGY192	CD Diagram:	CD0006	Mfg Plant:	
Mech. Spec:	12G154	Layout:	12LYG154	Poles:	02	Created Date:	01-27-2015
Base:	RG	Eff. Date:	02-14-2022	Leads:	3#8		

Specs			
Catalog Number:	ECP4109T-4	Inverter Code:	Inverter Duty
Enclosure:	TEFC	KVA Code:	H
Frame:	324TS	Lifting Lugs:	Standard Lifting Lugs
Frame Material:	Iron	Locked Bearing Indicator:	Locked Bearing
Output @ Frequency:	40.000 HP @ 60 HZ	Motor Lead Quantity/Wire Size:	3 @ 8 AWG
Synchronous Speed @ Frequency:	3600 RPM @ 60 HZ	Motor Lead Exit:	Ko Box
Voltage @ Frequency:	460.0 V @ 60 HZ	Motor Lead Termination:	Flying Leads
XP Class and Group:	CLI GP A,B,C,D	Motor Type:	1244M
XP Division:	Division II	Mounting Arrangement:	F1
Agency Approvals:	CSA	Power Factor:	88
	CSA EEV	Product Family:	Super-E Chemical Processing
	UR	Pulley End Bearing Type:	Ball
Auxillary Box:	No Auxillary Box	Pulley Face Code:	Standard
Auxillary Box Lead Termination:	None	Pulley Shaft Indicator:	Standard
Base Indicator:	Rigid	Rodent Screen:	None
Bearing Grease Type:	Polyrex EM (-20F +300F)	RoHS Status:	ROHS NON-COMPLIANT
Blower:	None	Shaft Extension Location:	Pulley End
Constant Torque Speed Range:	6	Shaft Ground Indicator:	No Shaft Grounding

Current @ Voltage:	46.000 A @ 460.0 V	Shaft Rotation:	Reversible
Design Code:	A	Shaft Slinger Indicator:	Shaft Slinger
Drip Cover:	No Drip Cover	Speed Code:	Single Speed
Duty Rating:	CONT	Motor Standards:	NEMA
Electrically Isolated Bearing:	Not Electrically Isolated	Starting Method:	Direct on line
Feedback Device:	NO FEEDBACK	Thermal Device - Bearing:	None
Front Face Code:	Standard	Thermal Device - Winding:	None
Front Shaft Indicator:	None	Vibration Sensor Indicator:	No Vibration Sensor
Heater Indicator:	No Heater	Winding Thermal 1:	None
Insulation Class:	F	Winding Thermal 2:	None
		XP Temp Code:	T3

Nameplate NP3241

CAT.NO.	ECP4109T-4	P/N		ENCLOSURE	TEFC
SPEC.	12G154Y192G2	CC	010A	FRAME	324TS
HP	40	CLASS	F	HZ	60
RPM	3540	RPM MAX	5400	PH	3
VOLT	460	MOTOR WEIGHT	635	ODE BRG	6312
AMP	46	SER.F.	1.15	PF	88
RATING	40C AMB-CONT	NEMA-NOM-EFF	93	DE BRG	6312
		GREASE	POLYREX EM		
		INV.TYPE	PWM		
TEMP CODE	T3	INVERTER-TEMP-CODE	200		
TEMP =	200	C HP FR	60	C HP TO	90
CT HZ FROM	6	CT HZ TO	60		
HTR-VOLTS		HTR-AMPS		HTR-WATTS	
		MAX. SPACE HEATER TEMP.		VT HZ FROM	3
				VT HZ TO	60

Parts List		
Part Number	Description	Quantity
SA292956	SA 12G154Y192G2	1.000 EA
RA279062	RA 12G154Y192G2	1.000 EA
37FN3002C04	EXFN, PLASTIC, 6.00 OD, 2.003 ID	1.000 EA
10CB1000A203P	KOBX W/2.00 NPT & .31 GND MTG, EPOXY PRI	1.000 EA
09GS1010	GASKET, DWG, LEADWIRE SEPERATOR	1.000 EA
10XN3118K16	5/16-18 X 1' GRADE #5, STL, ZINC PLATE	4.000 EA
HW1001A31	LOCKWASHER 5/16, ZINC PLT.591 OD, .319 I	4.000 EA
WD1000B25	GND LUG, BURNDY L125HP OR T&B L125HP-BB	1.000 EA
19XW3118G08	.31-18X.50,HEX WSHR HD,TAPTITE 2,GREEN	1.000 EA
HW1001A31	LOCKWASHER 5/16, ZINC PLT.591 OD, .319 I	1.000 EA
HA4017A10	1/8X1.25 GREASE EXT (F/S)	1.000 EA
HW4019A01	PIPE COUPLING 1/8 NPT,STEEL,ZINC COATING	1.000 EA
HA4017A01	1/8 X 4 GREASE EXT (F/S)	1.000 EA
HW4500A20	1/8NPT SL PIPE PLUG	1.000 EA
HA3400A32	STUD, 1/2-13 X 7.38	4.000 EA
HW1001A50	LOCKWASHER 1/2, ZINC PLT.,.879 OD, .509 I	4.000 EA
HA1005A04	SLINGER, OD 3.620, ID 1.98,	1.000 EA
HW5100A15	W4997-050 WVY WSHR (WB)	1.000 EA
10XN3118K42	5/16-18 X 2.63" HEX HD, GRADE 5	4.000 EA
12EP1111A30P	SPL PUEP 312 BRG W/EPOXY	1.000 EA
10XN5013K28	1/2-13 X 1.75 HEX HEAD MACH SCREW,GRAD	4.000 EA
HW1001A50	LOCKWASHER 1/2, ZINC PLT.,.879 OD, .509 I	4.000 EA
HW4500A20	1/8NPT SL PIPE PLUG	1.000 EA
HW4600B41	V-RING SLINGER 2.125 X 2.880 X 0.280	1.000 EA

Parts List (continued)		
Part Number	Description	Quantity
10XN3118K40	5/16-18 X 2.50" HEX HD, GRADE 5	4.000 EA
12FH1002A33P	FAN COVER, MACH ,EPOXY PRIMER	1.000 EA
XY5013A12	NUT,1/2-13,HEX,STEEL,ZINCPLATED	4.000 EA
HW1001A50	LOCKWASHER 1/2, ZINC PLT.,.879 OD, .509 I	4.000 EA
10CB1503A01P	CONDUIT BOX LIPPED LID, MACH W/EPXY PRMR	1.000 EA
14GS1003	GASKET CONDUIT BOX LID, NEOP	1.000 EA
10XN2520K16	1/4-20 X 1" HX HD SCRW GRADE 5, ZINC P	4.000 EA
HW1001A25	LOCKWASHER 1/4, ZINC PLT .493 OD, .255 I	4.000 EA
HW2501H18	KEY, 1/2 SQ X 2.000	1.000 EA
MJ5001A27	32220KN GRAY SEALER *MIN BUY 4 QTS=1GAL	0.031 QT
MJ5002A01	SILICON RUBBER SEALANT, 732CL 10.3 OZ TU	0.033 EA
MJ5002A01	SILICON RUBBER SEALANT, 732CL 10.3 OZ TU	0.025 EA
LB1115N	LABEL,LIFTING DEVICE (ON ROLLS)	1.000 EA
12EP1111A35GP6	FR ENDPLATE, MACH W/EPOXY PRIMER & RELIA	1.000 EA
HA4051A00	PLASTIC CAP FOR GREASE FITTING	1.000 EA
HW4500A21	1618BALEMITE FITTING 825 UNIVERSAL	1.000 EA
HW4500A17	317400 ALEMITE GREASE RELIEF	1.000 EA
HA4001A01SP	DRAIN PLUG, PLASTIC (MICRO PLAS)	1.000 EA
MJ1000A02	GREASE, MOBIL POLYREX EM - 124047	0.200 LB
HA4051A00	PLASTIC CAP FOR GREASE FITTING	1.000 EA
HW4500A03	GREASE FITTING, .125 NPT 1610(ALEMITE) 8	1.000 EA
HW4500A17	317400 ALEMITE GREASE RELIEF	1.000 EA
HA4001A01SP	DRAIN PLUG, PLASTIC (MICRO PLAS)	1.000 EA
HW2500A25	WOODRUFF KEY USA #1008 #BLOW CARBON STEE	1.000 EA

Product Information Packet: ECP4109T-4 - 40HP,3540RPM,3PH,60HZ,324TS,1244M,TEFC,F

51XB1214A20	12-14X1.25 HXWSSLD SERTYB	1.000 EA
MG1025N19	WILKOFAS, 778.50, RELIANCE BLUE-GREEN	0.080 GA
85XU0407S04	4X1/4 U DRIVE PIN STAINLESS	4.000 EA
LB1119N	WARNING LABEL	1.000 EA
LC0006	CONNECTION LABEL	1.000 EA
NP3241	SS SUPER-E INV UL CSA-EEV PREM CC	1.000 EA
12PA1000	PACKAGING GROUP PRINT PK1024A07	1.000 EA
LB1449	DIV-2/NEC WARNING LABEL	1.000 EA
MN416A01	TAG-INSTAL-MAINT no wire (2100/bx) 4/22	1.000 EA
LB1002N	LABEL,MARINE DUTY (ON ROLLS)	1.000 EA

Accessories		
Part Number	Description	Multiplier
12-1105ECP	C FACE KIT (C-FACE SWAP FOR ECP MOTOR)	A8

AC Induction Motor Performance Data

Record # 47241

Typical performance - not guaranteed values

Winding: 12WGY192-R006		Type: 1244M	Enclosure: TEFC
Nameplate Data		460 V, 60 Hz: Single Voltage Motor	
Rated Output (HP)	40	Full Load Torque	59.3 LB-FT
Volts	460	Start Configuration	direct on line
Full Load Amps	46	Breakdown Torque	235 LB-FT
R.P.M.	3540	Pull-up Torque	84.3 LB-FT
Hz	60 Phase	Locked-rotor Torque	100 LB-FT
NEMA Design Code	A KVA Code	Starting Current	352 A
Service Factor (S.F.)	1.15	No-load Current	15.5 A
NEMA Nom. Eff.	93 Power Factor	Line-line Res. @ 25°C	0.13313 Ω
Rating - Duty	40C AMB-CONT	Temp. Rise @ Rated Load	67°C
S.F. Amps		Temp. Rise @ S.F. Load	80°C
		Rotor inertia	3.44 LB-FT ²

Load Characteristics 460 V, 60 Hz, 40 HP

% of Rated Load	25	50	75	100	125	150	S.F.
Power Factor	57	76	84	88	89	89	89
Efficiency	88	92.2	93.2	93.3	93	92.4	93.1
Speed	3585.6	3575.4	3564.2	3553.6	3540.6	3527.7	3546
Line amperes	19.4	27.1	36.3	46.3	57.3	68.5	52.9

Performance Graph at 460V, 60Hz, 40.0HP Typical performance - Not guaranteed values

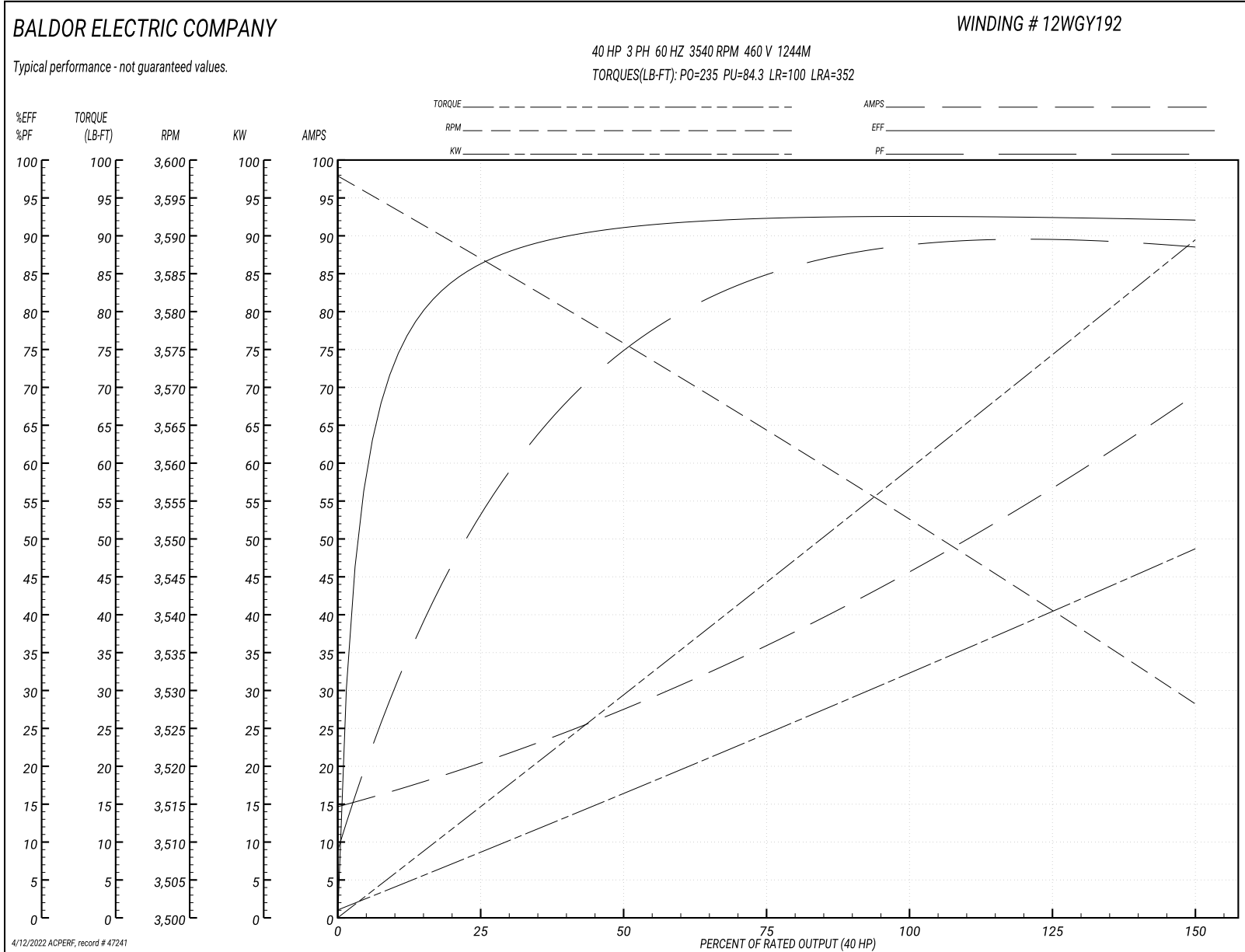

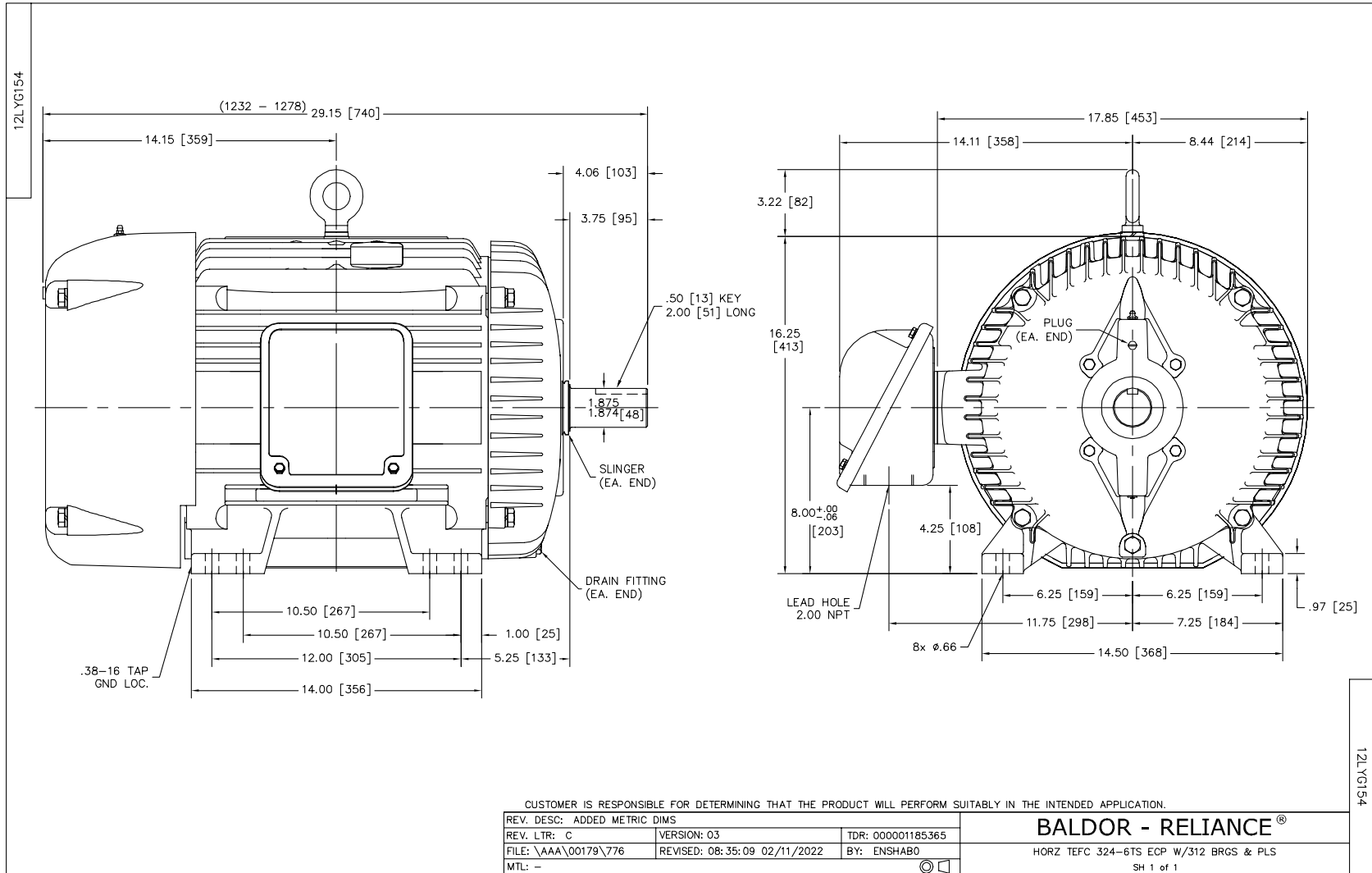

CD0006



NOTES:

1. THREE LEAD MOTOR MAY BE EITHER WYE CONNECTED OR DELTA CONNECTED.
2. INTERCHANGE ANY TWO LINE LEADS TO REVERSE ROTATION.
3. OPTIONAL THERMOSTATS ARE PROVIDED WHEN SPECIFIED.
4. ACTUAL NUMBER OF INTERNAL PARALLEL CIRCUITS MAY VARY.
5. LEAD COLORS ARE OPTIONAL. LEADS MUST BE NUMBERED AS SHOWN.

CD0006

REV. DESC: ADD CLASS CONN00000007		
REV. LTR: E	VERSION: 01	TDR: 000001099922
FILE: \AAA\00005\141	REVISED: 10:24:49 02/19/2019	BY: ENBRIRO
MTL: -	© □	

BALDOR - RELIANCE®

3PH, SV, 3 LEADS, WYE OR DELTA CONNECTED

SH 1 of 1

Marketing maintained PDF of MN416:

<http://www.baldor.com/support/Literature/Load.ashx/MN416?ManNumber=MN416>