



Customer information packet

ECP4314T

60HP, 1780RPM, 3PH, 60HZ, 364T, A3658M, TEFC, F

Class - CLI GP A,B,C,D

Division - Division II

Specifications

Enclosure	TEFC
Frame	364T
Frame Material	Iron
Frequency	60.00 Hz
Motor Letter Type	Three Phase
Output @ Frequency	60.000 HP @ 60 HZ
Phase	3
Synchronous Speed @ Frequency	1800 RPM @ 60 HZ
Voltage @ Frequency	230.0 V @ 60 HZ 460.0 V @ 60 HZ
XP Class and Group	CLIP A,B,C,D
XP Division	Division II
Agency Approvals	CCSA US CSA EEV NEMA PREMIUM UR
Ambient Temperature	40 °C
Auxillary Box	No Auxillary Box
Base Indicator	Rigid
Bearing Grease Type	Polyrex EM (-20F +300F)
Constant Torque Speed Range	10-60
Current @ Voltage	70.000 A @ 460.0 V 152.000 A @ 208.0 V 140.000 A @ 230.0 V
Design Code	B
Drip Cover	No Drip Cover
Duty Rating	CONT
Efficiency @ 100% Load	95.0 %
Feedback Device	NO FEEDBACK
Heater Indicator	No Heater
High Voltage Full Load Amps	70.0 a
Insulation Class	F

Part detail

Revision	X
Type	AC
Mech. spec.	
Base	
Status	PRD/A
Elec. spec.	A36WG4075
Layout	617428-034
Eff. date	07-21-2021
CD Diagram	CD0180
Poles	04
Leads	3#4,6#6
Proprietary	False
Created date	10-19-2010

Inverter Code	Inverter Duty
KVA Code	G
Lifting Lugs	Standard Lifting Lugs
Max Speed	2700 rpm
Motor Lead Quantity/Wire Size	3 @ 4 AWG
Motor Standards	NEMA
Motor Type	A3658M
Mounting Arrangement	F1
Number of Poles	4
Overall Length	33.49 IN
Power Factor	84
Pulley End Bearing Type	Ball
Pulley Face Code	Standard
Service Factor	1.15
Shaft Diameter	2.375 IN
Shaft Ground Indicator	No Shaft Grounding
Shaft Rotation	Reversible
Shaft Slinger Indicator	Shaft Slinger
Speed	1780 rpm
Speed Code	Single Speed
Starting Method	Direct on line
Thermal Device - Bearing	None
Thermal Device - Winding	None
XP Temp Code	T3

Nameplate

NP4033LUA

CAT #	ECP4314T		SER			CC	010A					
SPEC	P36G3310		RATING	40C AMB-CONT								
HZ	VOLTS		AMPS	RPM	HP	CODE	-	SF	DES	PF	NEMA NOM. EFF	
60	230/460		140/70	1780	60	G		1.15	B	84 %	95 %	
										%	%	
PH	3	CL	F	MAX RPM	2700	MAX CORR KVAR	15	USABLE AT 208V	152	A		
BRG	DE	6313	ODE	6313	ENCL	TEFC	FR	364T	IP	55		
GREASE	POLYREX EM				MTR WT	867	LBS					
	CL I DIV 2 GRPS A,B,C,D			CL I ZONE 2 GRPS			IIA,IIB,IIC		TEMP T	200	C	
INV READY	CT	15-60	HZ	4:1	VT	3-60	HZ	20:1	CHP	60-90	HZ	1.5:1
INV TEMP CL	200	C	USABLE AT	50HZ 50HP 190/380V 138/69A					SF1.0			

Parts list

Part number	Description	Quantity
SA208276	SA P36G3310	1.000 ea
RA195541	RA P36G3310	1.000 ea
NP4033LUA	SS SUPER-E SD XEX CLI DIV2 UR CSA-C US-E	1.000 ea
000692000VD	LABEL WARNING	1.000 ea
421948032	LABEL, MYLAR	1.000 ea
004824015A	GREASE POLYREX EM	0.544 lb
032018008AK	HHCS 1/4-20X1 PLATED	4.000 ea
032018012DK	HHCS 1/2-13X1-1/2 PLTD. 032018012DR	4.000 ea
032018024CK	HHCS 3/8-16X3 PLTD.	3.000 ea
034180012DA	KEY 1X4X1/4X1-1/2 L	1.000 ea
034530052AB	P/NIP 1/8X6-1/2 Zinc	1.000 ea
078548001K	FAN KB 100/30 (70) 360	1.000 ea
078559034A	+F/C A 078559001A - 360	1.000 ea
085922073B	BRKT 360 085922072WCC KB	1.000 ea
410700004F	WSHR	1.000 ea
415045002E	SLGR	1.000 ea
415072001B	CLAMP	1.000 ea
415096002A	CPLG 1/8 HEX TYPE	1.000 ea
412118006A	DRAIN	1.000 ea
032018012DK	HHCS 1/2-13X1-1/2 PLTD. 032018012DR	4.000 ea
032018024CK	HHCS 3/8-16X3 PLTD.	3.000 ea
034530020AB	P/NIP 1/8X2-1/2 PLTED	1.000 ea
085922073B	BRKT 360 085922072WCC KB	1.000 ea
415045002E	SLGR	1.000 ea
415096002A	CPLG 1/8 HEX TYPE	1.000 ea
412118006A	DRAIN	1.000 ea
032018010CK	HHCS 3/8-16X1-1/4 PLTD. 032018010CR	4.000 ea
033512008LB	HHTTS 1/4-20X1 PLATED	4.000 ea
034000014AB	WSH ID.406 OD.812 TH.065	4.000 ea
035000001A	ALFTG 1/8" 1610-BL	1.000 ea
035000001A	ALFTG 1/8" 1610-BL	1.000 ea

065776000C	GASKET,MAIN CBOX, 320-400	1.000 ea
067053000B	GASK 320-400	1.000 ea
076708000BB	CONDUIT BOX-360	1.000 ea
076709000A	C/B Cover - 360	1.000 ea
406099000A	PLUG - FAN COVER 320-440	1.000 ea
415000115H	T/LUG #2AWG-4/0AWG	1.000 ea
418150003A	GREASE FITTING CAP	1.000 ea
033775004EA	DRSCR #6-1/4 304 S.S.	4.000 ea
418150003A	GREASE FITTING CAP	1.000 ea
034180034HA	KEY 5/8X5/8X4-1/4 L	1.000 ea
MG1025N19	WILKO 778.50 BLUE GREEN - 55 GAL DRUMS	0.250 ga
004824003CBY	WILKO PAINT 060.02 - ACTIVATOR	0.063 ga
14PA1000	PACKAGING 314 GROUP COMBINED PRINT	1.000 ea
000613006PU	N/P (RELEASE QTY 10,000) UL CSA LABEL	1.000 ea
034530032BB	P/NIP 1/4X4" SCHED 40	1.000 ea
034631002AB	BUSH 1/4 TO 1/8 PLTD.	1.000 ea
035000001G	GREASE RELIEF FITTING, ALEMITE 317400	1.000 ea
034631002AB	BUSH 1/4 TO 1/8 PLTD.	1.000 ea
034530020BB	P/NIP 1/4X2-1/2 PLATED	1.000 ea
035000001G	GREASE RELIEF FITTING, ALEMITE 317400	1.000 ea
LB1449	DIV-2/NEC WARNING LABEL	1.000 ea
032018005DL	1/2-13 X 5/8 SILICON BRONZE HHCS	1.000 ea

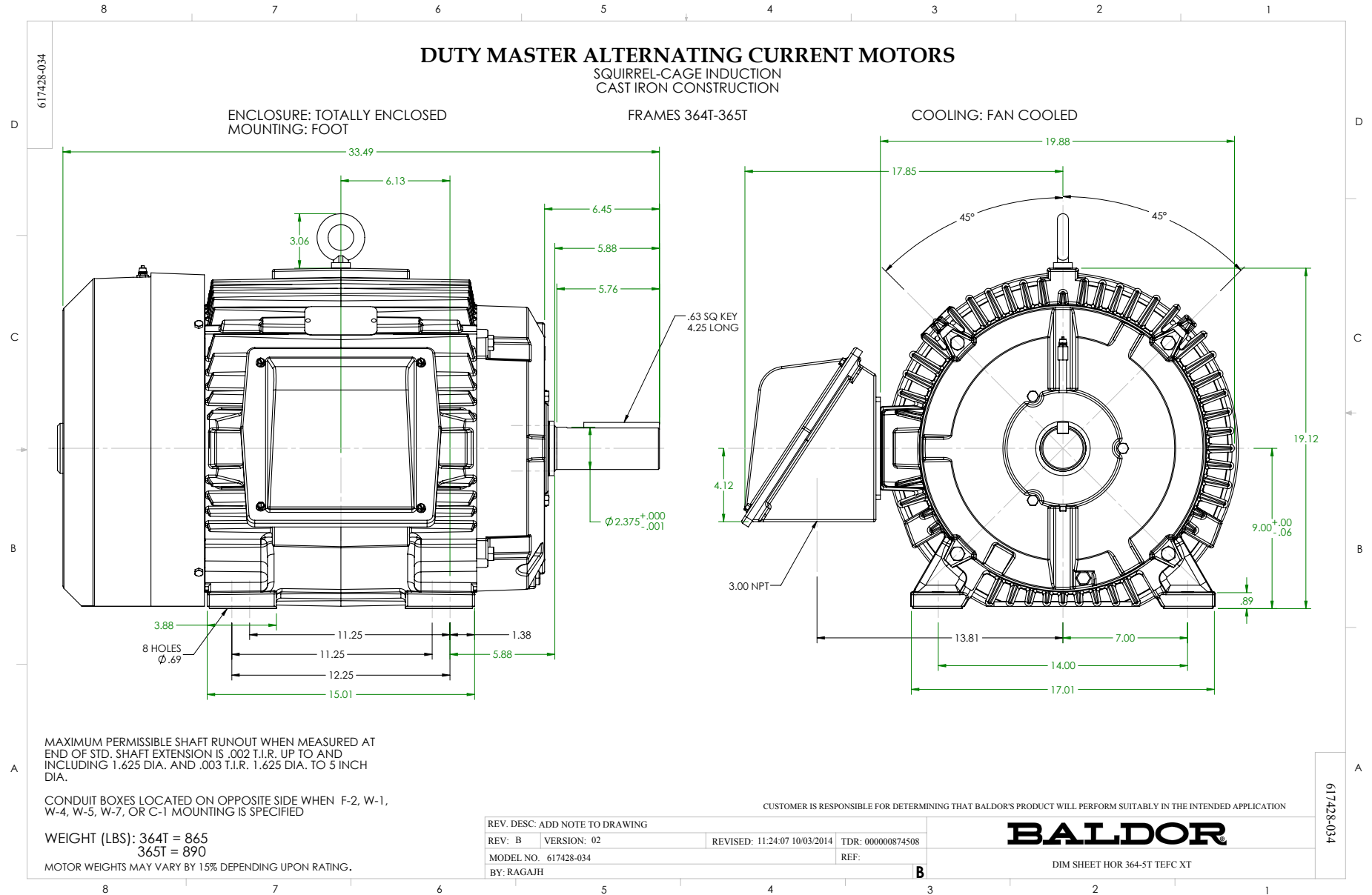

CD0180

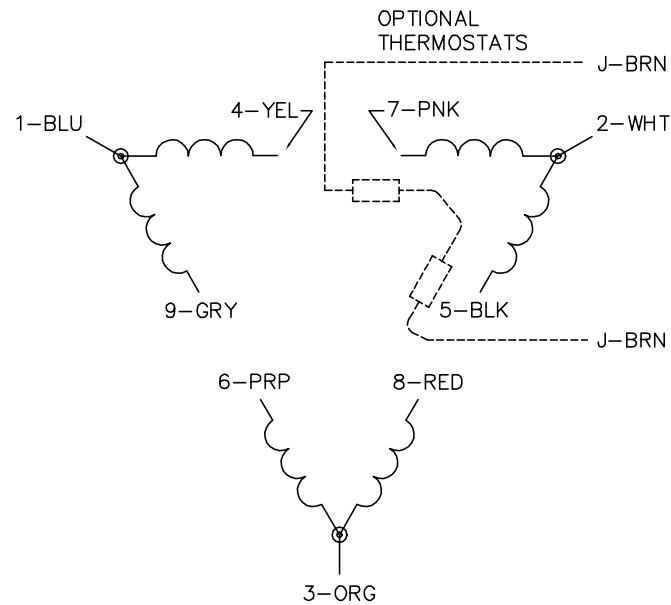

LOW VOLTAGE
(2D)

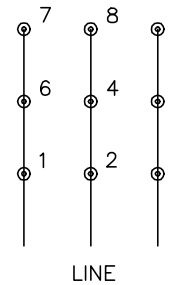

HIGH VOLTAGE
(1D)

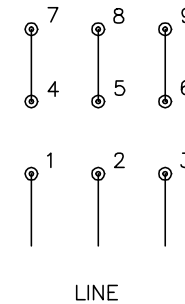

NOTES:

1. INTERCHANGE ANY TWO LINE LEADS TO REVERSE ROTATION.
2. OPTIONAL THERMOSTATS ARE PROVIDED WHEN SPECIFIED.
3. ACTUAL NUMBER OF INTERNAL PARALLEL CIRCUITS MAY BE A MULTIPLE OF THOSE SHOWN ABOVE.
4. LEAD COLORS ARE OPTIONAL. LEADS MUST ALWAYS BE NUMBERED AS SHOWN.

CD0180

REV. DESC: ADD CLASS CONN00000007		
REV. LTR: D	VERSION: 01	TDR: 000001099922
FILE: \AAA\00005\148	REVISED: 10: 25: 29 02/19/2019	BY: ENBRIRO
MTL: -	© □	

BALDOR - RELIANCE®

3PH, DV, 9 LEADS, DELTA CONNECTION

SH 1 of 1