



Customer information packet

ECP4421T-4

125HP, 885RPM, 3PH, 60HZ, 447T, TEFC, F1

Class - None

Division - Division II

Specifications

Enclosure	TEFC
Frame	447T
Frame Material	Iron
Frequency	60.00 Hz
Motor Letter Type	Three Phase
Output @ Frequency	125.000 HP @ 60 HZ
Phase	3
Synchronous Speed @ Frequency	900 RPM @ 60 HZ
Voltage @ Frequency	460.0 V @ 60 HZ
XP Class and Group	None
XP Division	Division II
Agency Approvals	CSA EEV
Ambient Temperature	40 °C
Auxillary Box	No Auxillary Box
Base Indicator	Rigid
Bearing Grease Type	Polyrex EM (-20F +300F)
Constant Torque Speed Range	30-60
Current @ Voltage	149.000 A @ 460.0 V
Design Code	B
Drip Cover	No Drip Cover
Duty Rating	CONT
Efficiency @ 100% Load	95.0 %
Feedback Device	NO FEEDBACK
Heater Indicator	No Heater
High Voltage Full Load Amps	149.0 a
Insulation Class	B
Inverter Code	Inverter Ready
KVA Code	F
Lifting Lugs	No Lifting Lugs
Motor Lead Quantity/Wire Size	3 @ 1/0 AWG
Motor Standards	NEMA
Motor Type	A44104M

Part detail

Revision	G
Type	AC
Mech. spec.	
Base	
Status	PRD/A
Elec. spec.	A44WG2397
Layout	617427-002
Eff. date	04-19-2021
CD Diagram	416820-036
Poles	08
Leads	3#1/0
Proprietary	False
Created date	01-09-2014

Mounting Arrangement	F1
Number of Poles	8
Overall Length	48.24 IN
Power Factor	83
Pulley End Bearing Type	Ball
Pulley Face Code	Standard
Service Factor	1.15
Shaft Diameter	3.375 IN
Shaft Ground Indicator	No Shaft Grounding
Shaft Rotation	Reversible
Shaft Slinger Indicator	Shaft Slinger
Speed	885 rpm
Speed Code	Single Speed
Starting Method	Direct on line
Thermal Device - Bearing	None
Thermal Device - Winding	None
XP Temp Code	T3

Nameplate

NP3238

CAT NO	ECP4421T-4	SPEC NO.	A44-5310-2397						
HP	125	AMPS	149	VOLTS	460	DESIGN	B		
FRAME	447T	RPM	885	HZ	60	AMB	40	SF	1.15
D.E. BRG.DATA	6318	O.D.E. BRG.DATA	6318	PH	3	DUTY	CONT	INSUL.CLASS	F
D.E. BRG.	90BC03J30X	TYPE	P	ENCL	TEFC	CODE	F		
O.D.E. BRG.	90BC03J30X	POWER FACTOR	83	NEMA NOM EFFICIENCY	95				
3/4 LOAD EFF.	95.4	MAX CORR KVAR	30.0	GUARANTEED EFFICIENCY	94.1				
TEMP CODE	T3	TEMP =	200						
CHP HZ	60-90	CT HZ	30-60	VT HZ	0-60				
INVERTER-TEMP-CODE	T3								
SER.NO.		MOTOR WEIGHT							

Parts list

Part number	Description	Quantity
SA274540	SA A44-5310-2397	1.000 ea
RA261125	RA A44-5310-2397	1.000 ea
NP3238	SS CP XEX SEVERE DUTY MAIN NP	1.000 ea
000692000FF	N/P	1.000 ea
000692000VD	LABEL WARNING	1.000 ea
000613006PU	N/P (RELEASE QTY 10,000) UL CSA LABEL	1.000 ea
421948051	LABEL, MYLAR	1.000 ea
004824015A	GREASE POLYREX EM	1.156 lb
032018008CK	HHCS 3/8-16X1L PLATED	4.000 ea
032018020FK	HHCS 3/4-10X2-1/2 PLTD.	4.000 ea
032018030DK	HHCS 1/2-13X3-3/4 PLTD.	3.000 ea
032620016LA	SOCKET SET SCREW-449	3.000 ea
034017014AB	LCKW 3/8 STD. PLATED	4.000 ea
034180014DA	KEY 1/4X1/4X1-3/4 L	1.000 ea
034530072AB	P/NIP 1/8X9"L Threaded both ends	1.000 ea
034530072BB	PIPE NIPPLE,DE - 440-BS	1.000 ea
034631002AB	BUSH 1/4 TO 1/8 PLTD.	1.000 ea
034690005AB	PPLG 3/4 PLATED	2.000 ea
702618004T	FAN KB 182/70 (112) 440	1.000 ea
083199082A	G28 FAN COVER MACHINING SHORT VERSION	1.000 ea
089490099A	G28 BRKT 089490098WCA KB	1.000 ea
410700004A	WSHR	1.000 ea
415045002A	SLGR	1.000 ea
415072001B	CLAMP	1.000 ea
415096002A	CPLG 1/8 HEX TYPE	1.000 ea
032018004BK	HHCS 5/16-18X1/2 PLATED	3.000 ea
032018020FK	HHCS 3/4-10X2-1/2 PLTD.	4.000 ea
032018030DK	HHCS 1/2-13X3-3/4 PLTD.	3.000 ea
034017013AB	LCKW 5/16 STD. PLATED	3.000 ea
034530044AB	P/NIP 1/8X5-1/2L GALV.	1.000 ea
034530044BB	P/NIP 1/4X5-1/2L PLT	1.000 ea

034631002AB	BUSH 1/4 TO 1/8 PLTD.	1.000 ea
089490099A	G28 BRKT 089490098WCA KB	1.000 ea
415045002A	SLGR	1.000 ea
415096002A	CPLG 1/8 HEX TYPE	1.000 ea
415915007G	GASK, LAC	1.000 ft
418151014G	RETAIN RING	1.000 ea
702623013A	THERMAL BARRIER -- G28 -- BRACKET MTD	1.000 ea
032018008BK	HHCS 5/16-18X1L PLATED	4.000 ea
032018008DK	HHCS 1/2-13X1 PLATED	4.000 ea
032018005DL	1/2-13 X 5/8 SILICON BRONZE HHCS	1.000 ea
035000001A	ALFTG 1/8" 1610-BL	1.000 ea
035000001A	ALFTG 1/8" 1610-BL	1.000 ea
067053014A	GASK 440	1.000 ea
076870000BA	CONDUIT BOX - 440 - 1/2-13 GROUND	1.000 ea
076871000A	+CBOX CVR BLKT - 449	1.000 ea
406056007A	GASKET, 440	1.000 ea
406099000A	PLUG - FAN COVER 320-440	1.000 ea
415000115H	T/LUG #2AWG-4/0AWG	1.000 ea
418150003A	GREASE FITTING CAP	1.000 ea
418150003A	GREASE FITTING CAP	1.000 ea
MG1025N19	WILKO 778.50 BLUE GREEN - 55 GAL DRUMS	0.375 ga
033775004EA	DRSCR #6-1/4 304 S.S.	2.000 ea
034180054KA	7/8 SQ X 6.75 KEY	1.000 ea
604797056	WOOD BASE 447 60 X 41-1/2 BLT 20 X 18	1.000 ea
032510026D	CARRIAGE BOLT - 440	2.000 ea
034001016AB	WSHR .562ID 1.375OD .109	2.000 ea
034001014AB	FLAT WASHER 3/8"PLATED	2.000 ea
033300014AC	HEX NUT, SHIPPING - 400	2.000 ea
604799003C	PLASTIC BAG 42X32X46	1.000 ea
LB1449	DIV-2/NEC WARNING LABEL	1.000 ea
035000001G	GREASE RELIEF FITTING, ALEMITE 317400	1.000 ea
035000001G	GREASE RELIEF FITTING, ALEMITE 317400	1.000 ea
412118006A	DRAIN	2.000 ea

617427-002

DUTY MASTER ALTERNATING CURRENT MOTORS

SQUIRREL-CAGE INDUCTION

ENCLOSURE: TOTALLY ENCLOSED

FRAME G447T ABOVE NEMA RATINGS

COOLING: FAN COOLED

MOUNTING: FOOT

INCLUDES 445T FRAME MOUNTING HOLES

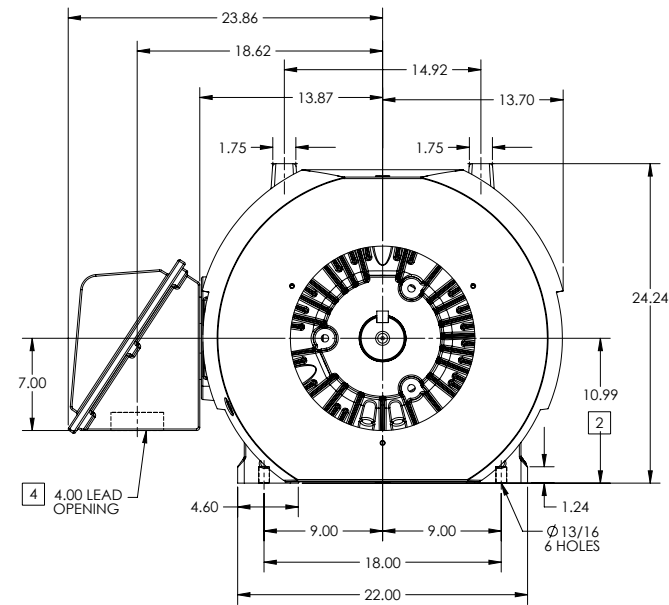
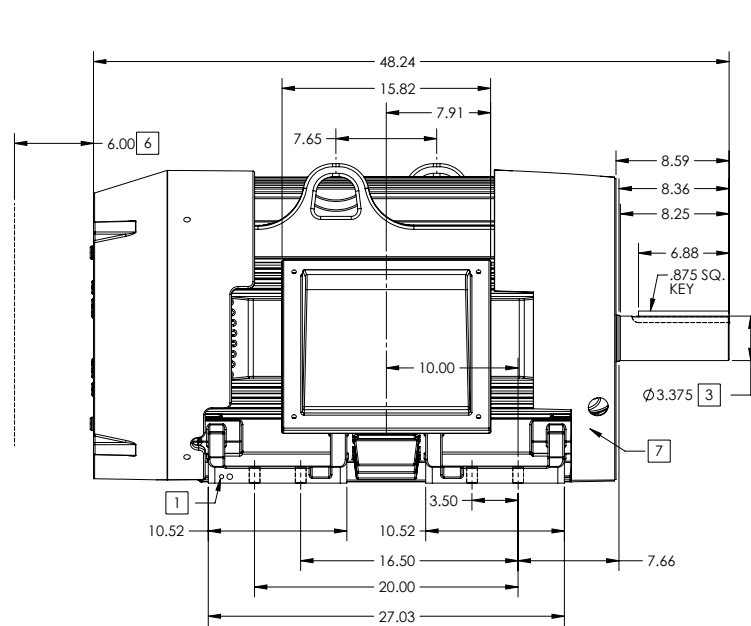

- 1. GROUND HOLES QTY 1 1/2-13 TAP; QTY 1 3/8-16 TAP
- 2. VARIES +.00, -.06
- 3. VARIES +.000, -.001
- 4. ON STANDARD MOTORS THIS IS CONDUIT SIZE. ON XT AND CORROSION PROOF MOTOR THIS IS PIPE TAP.
- 5. MOTOR WEIGHTS MAY VARY BY 15% DEPENDING ON RATING.
- 6. OBSTRUCTION MUST NOT ENCR OACH ON AIR INLET.
- 7. AIR DEFLECTOR INSTALLED WHEN REQUIRED.

CONDUIT BOX LOCATED ON OPPOSITE SIDE WHEN F-2.
IF MOUNTING CLEARANCE DETAILS ARE REQUIRED, CONSULT FACTORY.
MAXIMUM PERMISSIBLE SHAFT RUNOUT WHEN MEASURED AT END OF STANDARD SHAFT EXTENSION IS .003" T.I.R. TO 5 INCH DIA.

5 WEIGHT (LBS): 2515

DRIVE END AIR DEFLECTOR IS ONLY INCLUDED WHEN NECESSARY.

DIMENSIONS ARE IN INCHES; SEE SHEET 2 FOR DIMENSIONS IN MILLIMETERS

CUSTOMER IS RESPONSIBLE FOR DETERMINING THAT MOTOR PERFORMANCE IS SUITABLE IN THE APPLICATION.

SHEET NUMBER
1 OF 2

2007-27-19

REV. DESC: CHANGING ENCLOSURE TO "TOTALLY ENCLOSED" WAS "UL..."			
REV: A	VERSION: 01	REVISED: 08-25-13 02:15/2013	TDR: 000000786306
MODEL NO. 617427-002		REF:	
BY: MGHWC	Material:	C	

BALDOR

G447T-445T STD - FOOTED - SIDE CENTER C/B

617427-002

617427-002

DUTY MASTER ALTERNATING CURRENT MOTORS

SQUIRREL-CAGE INDUCTION

ENCLOSURE: TOTALLY ENCLOSED

FRAME G447T ABOVE NEMA RATINGS

COOLING: FAN COOLED

MOUNTING: FOOT

INCLUDES 445T FRAME MOUNTING HOLES

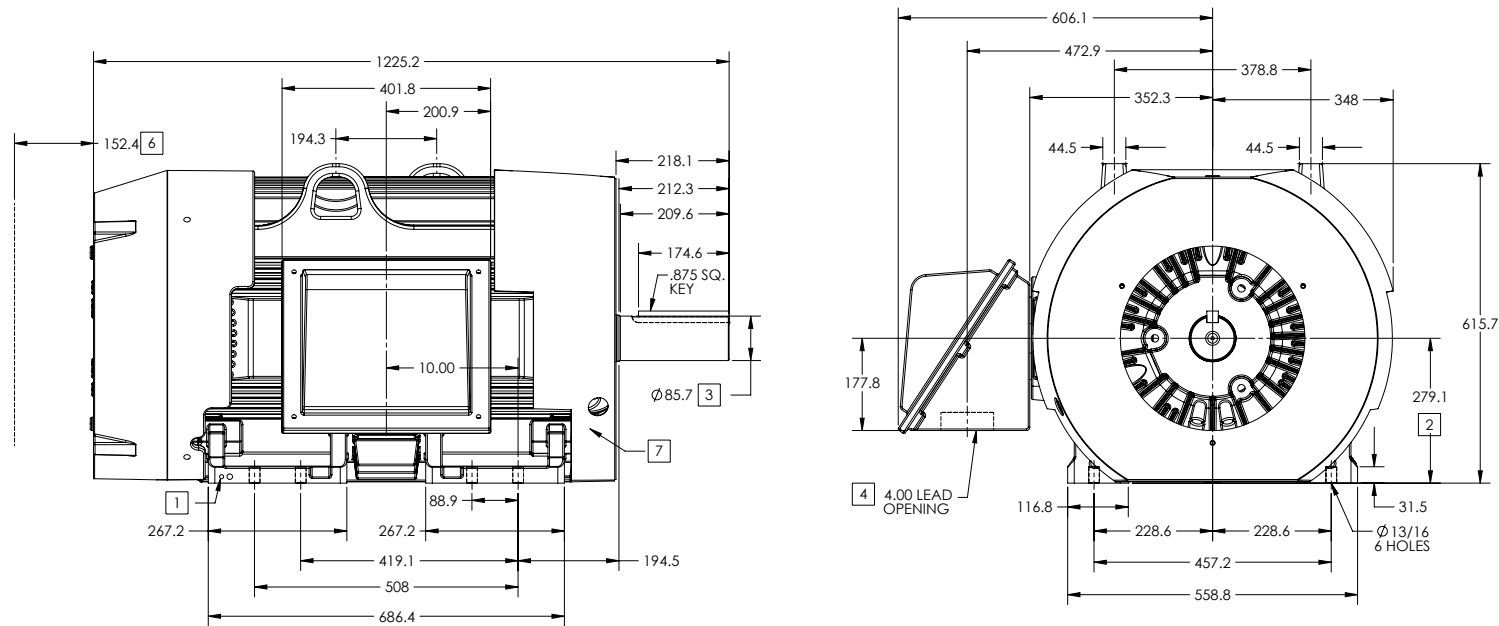

1. GROUND HOLES QTY 1 1/2-13 TAP; QTY 1 3/8-16 TAP
2. VARIES +.00, -.06
3. VARIES +.000, -.001
4. ON STANDARD MOTORS THIS IS CONDUIT SIZE. ON XT AND CORROSION PROOF MOTOR THIS IS PIPE TAP.
5. MOTOR WEIGHTS MAY VARY BY 15% DEPENDING ON RATING.
6. OBSTRUCTION MUST NO ENCROACH ON AIR INLET.
7. AIR DEFLECTOR INSTALLED WHEN REQUIRED.

CONDUIT BOX LOCATED ON OPPOSITE SIDE WHEN F-2.
IF MOUNTING CLEARANCE DETAILS ARE REQUIRED, CONSULT FACTORY.
MAXIMUM PERMISSIBLE SHAFT RUNOUT WHEN MEASURED AT END OF STANDARD SHAFT EXTENSION IS .08 MM T.I.R. TO 127 MM DIA.

5 WEIGHT (KGS): 1140

DRIVE END AIR DEFLECTOR IS ONLY INCLUDED WHEN NECESSARY.

DIMENSIONS ARE IN MILLIMETERS; SEE SHEET 1 FOR DIMENSIONS IN INCHES

CUSTOMER IS RESPONSIBLE FOR DETERMINING THAT MOTOR PERFORMANCE IS SUITABLE IN THE APPLICATION.

REV. DESC-CHANGING ENCLOSURE TO "TOTALLY ENCLOSED" WAS "UL..."			
REV: A	VERSION: 01	REVISED: 08-25-13 02:15/2013	TDR: 000000786306
MODEL NO. 617427-002		REF:	
BY: MGHWC	Material:	C	

BALDOR

G447T-445T STD - FOOTED - SIDE CENTER CB

617427-002

SHAFT-BLK	Sample- <u>BLK</u>	Diameter <u>AP</u>	Sequence # <u>0000001 A</u>	Material Spec <u>BLKAP0000001A</u>																																																																																																																																											
	<table border="1" style="width: 100%; border-collapse: collapse;"> <thead> <tr> <th style="width: 10%;">Diameter</th> <th style="width: 10%;">Code</th> <th style="width: 10%;">Sequence #</th> <th style="width: 40%;">Material Spec</th> <th style="width: 10%;">Code</th> </tr> </thead> <tbody> <tr><td>1.5</td><td>AA</td><td>XXXXXXX</td><td>046024-</td><td></td></tr> <tr><td>1.625</td><td>AB</td><td></td><td>FS CL1</td><td>A</td></tr> <tr><td>1.75</td><td>AC</td><td></td><td>FS CL2</td><td>B</td></tr> <tr><td>2</td><td>AD</td><td></td><td>AHS</td><td>C</td></tr> <tr><td>2.0625</td><td>AE</td><td></td><td>Z</td><td>D</td></tr> <tr><td>2.125</td><td>AF</td><td></td><td>NZ</td><td>E</td></tr> <tr><td>2.25</td><td>AG</td><td></td><td>GK</td><td>F</td></tr> <tr><td>2.5</td><td>AH</td><td></td><td>KA</td><td>G</td></tr> <tr><td>2.5625</td><td>AJ</td><td></td><td>APR CLVIII</td><td>J</td></tr> <tr><td>2.625</td><td>AK</td><td></td><td>LK</td><td>K</td></tr> <tr><td>2.75</td><td>AL</td><td></td><td>FS CL4</td><td>L</td></tr> <tr><td>3</td><td>AM</td><td></td><td>AAJ</td><td>M</td></tr> <tr><td>3.125</td><td>AN</td><td></td><td>HV</td><td>N</td></tr> <tr><td>3.25</td><td>AP</td><td></td><td>TB</td><td>P</td></tr> <tr><td>3.375</td><td>AQ</td><td></td><td>MR3008D38</td><td>Q</td></tr> <tr><td>3.5</td><td>AR</td><td></td><td>MU3000C75</td><td>R</td></tr> <tr><td>3.75</td><td>AS</td><td></td><td>MU3000D38</td><td>S</td></tr> <tr><td>3.875</td><td>AT</td><td></td><td>MU3002D12</td><td>T</td></tr> <tr><td>4.25</td><td>AU</td><td></td><td>MU3002D75</td><td>V</td></tr> <tr><td>4.5</td><td>AV</td><td></td><td>MU3003E75</td><td>W</td></tr> <tr><td>4.75</td><td>AW</td><td></td><td>MU3007D00</td><td>X</td></tr> <tr><td>5</td><td>AX</td><td></td><td></td><td></td></tr> <tr><td>5.25</td><td>AY</td><td></td><td></td><td></td></tr> <tr><td>5.5</td><td>AZ</td><td></td><td></td><td></td></tr> <tr><td>5.75</td><td>BA</td><td></td><td></td><td></td></tr> <tr><td>6.5</td><td>BB</td><td></td><td></td><td></td></tr> <tr><td>7.75</td><td>BC</td><td></td><td></td><td></td></tr> </tbody> </table>				Diameter	Code	Sequence #	Material Spec	Code	1.5	AA	XXXXXXX	046024-		1.625	AB		FS CL1	A	1.75	AC		FS CL2	B	2	AD		AHS	C	2.0625	AE		Z	D	2.125	AF		NZ	E	2.25	AG		GK	F	2.5	AH		KA	G	2.5625	AJ		APR CLVIII	J	2.625	AK		LK	K	2.75	AL		FS CL4	L	3	AM		AAJ	M	3.125	AN		HV	N	3.25	AP		TB	P	3.375	AQ		MR3008D38	Q	3.5	AR		MU3000C75	R	3.75	AS		MU3000D38	S	3.875	AT		MU3002D12	T	4.25	AU		MU3002D75	V	4.5	AV		MU3003E75	W	4.75	AW		MU3007D00	X	5	AX				5.25	AY				5.5	AZ				5.75	BA				6.5	BB				7.75	BC		
Diameter	Code	Sequence #	Material Spec	Code																																																																																																																																											
1.5	AA	XXXXXXX	046024-																																																																																																																																												
1.625	AB		FS CL1	A																																																																																																																																											
1.75	AC		FS CL2	B																																																																																																																																											
2	AD		AHS	C																																																																																																																																											
2.0625	AE		Z	D																																																																																																																																											
2.125	AF		NZ	E																																																																																																																																											
2.25	AG		GK	F																																																																																																																																											
2.5	AH		KA	G																																																																																																																																											
2.5625	AJ		APR CLVIII	J																																																																																																																																											
2.625	AK		LK	K																																																																																																																																											
2.75	AL		FS CL4	L																																																																																																																																											
3	AM		AAJ	M																																																																																																																																											
3.125	AN		HV	N																																																																																																																																											
3.25	AP		TB	P																																																																																																																																											
3.375	AQ		MR3008D38	Q																																																																																																																																											
3.5	AR		MU3000C75	R																																																																																																																																											
3.75	AS		MU3000D38	S																																																																																																																																											
3.875	AT		MU3002D12	T																																																																																																																																											
4.25	AU		MU3002D75	V																																																																																																																																											
4.5	AV		MU3003E75	W																																																																																																																																											
4.75	AW		MU3007D00	X																																																																																																																																											
5	AX																																																																																																																																														
5.25	AY																																																																																																																																														
5.5	AZ																																																																																																																																														
5.75	BA																																																																																																																																														
6.5	BB																																																																																																																																														
7.75	BC																																																																																																																																														
NOTE: DIMENSION ARE IN INCHES																																																																																																																																															
		REV. DESC: NEW - LOAD TO BUS		TDR:1061922																																																																																																																																											
REV: -		REVISED: 2/22/2018	BY: RAGJSS1																																																																																																																																												
SHAFT BLANK PART NUMBER ASSIGNMENT																																																																																																																																															



SHAFT-BLK

416820-036

A-C MOTOR
CONNECTION DIAGRAM
STANDARD 3 LEAD CONNECTED



(N.P. 1575-BA)

416820-036

REV. DESC: LOADED TO BUS, C/R 335225		
REV. LTR: -	VERSION: 00	TDR: 000000538207
FILE: \MGA\00000\682	REVISED: 11:54:06 04/30/2010	
MTL: -	BY: RAGRA	

BALDOR

CONN DIAG - STANDARD 3 LEAD
SH 1 of 1