

BALDOR • RELIANCE

Customer information packet

ECP49454T-4

450HP, 1785RPM, 3PH, 60HZ, L 449T, A44208M, TE

Class - None

Division - Division II

Specifications

Enclosure	TEFC
Frame	L449T
Frame Material	Iron
Frequency	60.00 Hz
Motor Letter Type	Three Phase
Output @ Frequency	450.000 HP @ 60 HZ
Phase	3
Synchronous Speed @ Frequency	1800 RPM @ 60 HZ
Voltage @ Frequency	460.0 V @ 60 HZ
XP Class and Group	None
XP Division	Division II
Agency Approvals	CSA EEV
Ambient Temperature	40 °C
Auxillary Box	No Auxillary Box
Base Indicator	Rigid
Bearing Grease Type	Polyrex EM (-20F +300F)
Constant Torque Speed Range	30-60
Current @ Voltage	501.000 A @ 460.0 V
Design Code	B
Drip Cover	No Drip Cover
Duty Rating	CONT
Efficiency @ 100% Load	96.2 %
Feedback Device	NO FEEDBACK
Frame Prefix	L
Heater Indicator	Heater Included, 115 V
High Voltage Full Load Amps	501.0 a
Insulation Class	F
Inverter Code	Inverter Ready
IP Rating	NONE
KVA Code	F
Lifting Lugs	No Lifting Lugs
Motor Lead Quantity/Wire Size	12 @ 1 AWG

Part detail

Revision	C
Type	AC
Mech. spec.	
Base	
Status	PRD/A
Elec. spec.	A44WG4196
Layout	617423-352
Eff. date	03-12-2020
CD Diagram	416820-036
Poles	04
Leads	3#1 (04 per group)
Proprietary	False
Created date	10-13-2016

Motor Standards	NEMA
Motor Type	A44208M
Mounting Arrangement	F1
Number of Poles	4
Overall Length	60.21 IN
Power Factor	87
Pulley End Bearing Type	Ball
Pulley Face Code	Standard
Service Factor	1.15
Shaft Diameter	3.375 IN
Shaft Ground Indicator	No Shaft Grounding
Shaft Rotation	Reversible
Shaft Slinger Indicator	Shaft Slinger
Speed	1785 rpm
Speed Code	Single Speed
Starting Method	Direct on line
Thermal Device - Bearing	None
Thermal Device - Winding	RTD Only
XP Temp Code	T2C

Nameplate

NP3238

CAT NO	ECP49454T-4	SPEC NO.	P44G5920							
HP	450	AMPS	501	VOLTS	460	DESIGN	B			
FRAME	L 449T	RPM	1785	HZ	60	AMB	40	SF	1.15	
D.E. BRG.DATA	6222	O.D.E. BRG.DATA	6318		PH	3	DUTY	CONT	INSUL.CLASS	F
D.E. BRG.	110BC02J30X	TYPE	P	ENCL	TEFC	CODE	F			
O.D.E. BRG.	90BC03J30X	POWER FACTOR	87		NEMA NOM EFFICIENCY	96.2				
3/4 LOAD EFF.	96.5	MAX CORR KVAR	54.0		GUARANTEED EFFICIENCY	95.4				
TEMP CODE	T2C	TEMP =	230							
CHP HZ	60-90	CT HZ	30-60		VT HZ	6-60				
INVERTER-TEMP-CODE										
SER.NO.				MOTOR WEIGHT						

Parts list

Part number	Description	Quantity
SA328594	SA P44G5920	1.000 ea
RA316518	RA P44G5920	1.000 ea
NP3238	SS CP XEX SEVERE DUTY MAIN NP	1.000 ea
000692000FF	N/P	1.000 ea
000692000VD	LABEL WARNING	1.000 ea
004824015A	GREASE POLYREX EM	1.156 lb
032018008CK	HHCS 3/8-16X1L PLATED	4.000 ea
032018020FK	HHCS 3/4-10X2-1/2 PLTD.	4.000 ea
032018030DK	HHCS 1/2-13X3-3/4 PLTD.	3.000 ea
032620016LA	SOCKET SET SCREW-449	3.000 ea
032018030DK	HHCS 1/2-13X3-3/4 PLTD.	3.000 ea
034017014AB	LCKW 3/8 STD. PLATED	4.000 ea
034180014DA	KEY 1/4X1/4X1-3/4 L	1.000 ea
034530064AB	P/NIP 1/8 X 8" L Pipe Nipple	1.000 ea
034530064BB	P/NIP 1/4X8 PLATED	1.000 ea
034631002AB	BUSH 1/4 TO 1/8 PLTD.	1.000 ea
035000001G	GREASE RELIEF FITTING, ALEMITE 317400	1.000 ea
034690005AB	PPLG 3/4 PLATED	2.000 ea
078557001E	FAN 440 078557001F	1.000 ea
083199082RA	G28 SHORT FAN COVER W/BAFFLE ASSEMBLY	1.000 ea
089490099A	G28 BRKT 089490098WCA KB	1.000 ea
410700004A	WSHR	1.000 ea
412118006A	DRAIN	1.000 ea
415045002A	SLGR	1.000 ea
415072001B	CLAMP	1.000 ea
415096002A	CPLG 1/8 HEX TYPE	1.000 ea
032018004BK	HHCS 5/16-18X1/2 PLATED	3.000 ea
032018006BK	HHCS 5/16-18X3/4 PLATED	3.000 ea
032018020FK	HHCS 3/4-10X2-1/2 PLTD.	4.000 ea
034017013AB	LCKW 5/16 STD. PLATED	3.000 ea
034017013AB	LCKW 5/16 STD. PLATED	3.000 ea

034530056AB	1/8 X 7 PP NIPPLE	1.000 ea
034530056BB	P/NIP 1/4X7 SCHED 40	1.000 ea
034631002AB	BUSH 1/4 TO 1/8 PLTD.	1.000 ea
035000001G	GREASE RELIEF FITTING, ALEMITE 317400	1.000 ea
415915007G	GASK, LAC	1.000 ft
089490101A	G28 BRKT 089490100WCA	1.000 ea
412118006A	DRAIN	1.000 ea
415045002D	SLGR - 440 V1T45B	1.000 ea
415096002A	CPLG 1/8 HEX TYPE	1.000 ea
418151014H	RETAIN RING	1.000 ea
702623022A	G28 AIR DEFLECTOR DRIVE END -- PLASTIC	1.000 ea
702623013A	THERMAL BARRIER -- G28 -- BRACKET MTD	1.000 ea
032018008DK	HHCS 1/2-13X1 PLATED	4.000 ea
032130014DB	HSHCS1/2-13X1-3/4 PLATE	4.000 ea
033512004LB	HHTTS 1/4-20X1/2 PLTD.	1.000 ea
034000016AB	WSHR .531ID 1.062OD .095	4.000 ea
035000001A	ALFTG 1/8" 1610-BL	1.000 ea
035000001A	ALFTG 1/8" 1610-BL	1.000 ea
702616012RE	CONDUIT BOX	1.000 ea
406056008A	GASKET, TERBD 440	1.000 ea
406099000A	PLUG - FAN COVER 320-440	1.000 ea
415000103D	T/LUG #4AWG-1/0AWG W/HOLE FOR .250 BOLT	1.000 ea
415030115A	G28 C/BOX 415030114WCA	1.000 ea
418150003A	GREASE FITTING CAP	1.000 ea
418150003A	GREASE FITTING CAP	1.000 ea
033775004EA	DRSCR #6-1/4 304 S.S.	2.000 ea
034180054KA	7/8 SQ X 6.75 KEY	1.000 ea
MG1025N19	WILKO 778.50 BLUE GREEN - 55 GAL DRUMS	0.375 ga
004824003CBY	WILKO PAINT 060.02 - ACTIVATOR	0.094 ga
L482401016	SPRAY AC-29-7S	0.019 ga
421948051	LABEL, MYLAR	1.000 ea
415039027A	GASKET, G28 LEAD THROAT	2.000 ea
604799003C	PLASTIC BAG 42X32X46	1.000 ea
033300014AC	HEX NUT, SHIPPING - 400	2.000 ea

034001016AB	WSHR .562ID 1.375OD .109	2.000 ea
034001014AB	FLAT WASHER 3/8"PLATED	2.000 ea
032510026D	CARRIAGE BOLT - 440	2.000 ea
604797032	447/449 WIDE SHIPPING SKID 70" X 55"	1.000 ea
LB1449	DIV-2/NEC WARNING LABEL	1.000 ea
000613006PU	N/P (RELEASE QTY 10,000) UL CSA LABEL	1.000 ea

DUTY MASTER ALTERNATING CURRENT MOTORS
SQUIRREL-CAGE INDUCTION

617423-006

ENCLOSURE: TOTALLY ENCLOSED
MOUNTING: FOOT, F-1

GL449T/G449T FRAME MOUNTING HOLES

COOLING: FAN COOLED

OVERSIZED 14X14X12 STEEL BOX

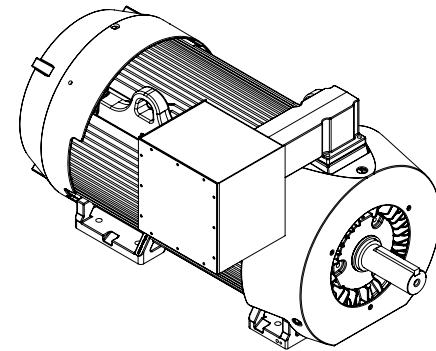
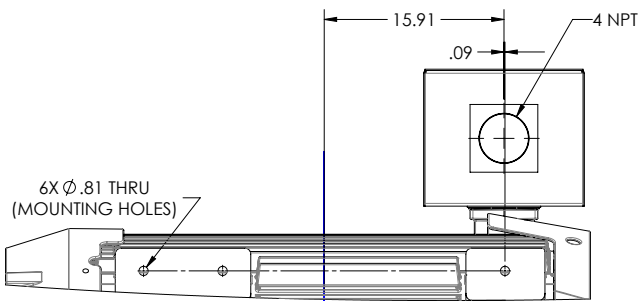
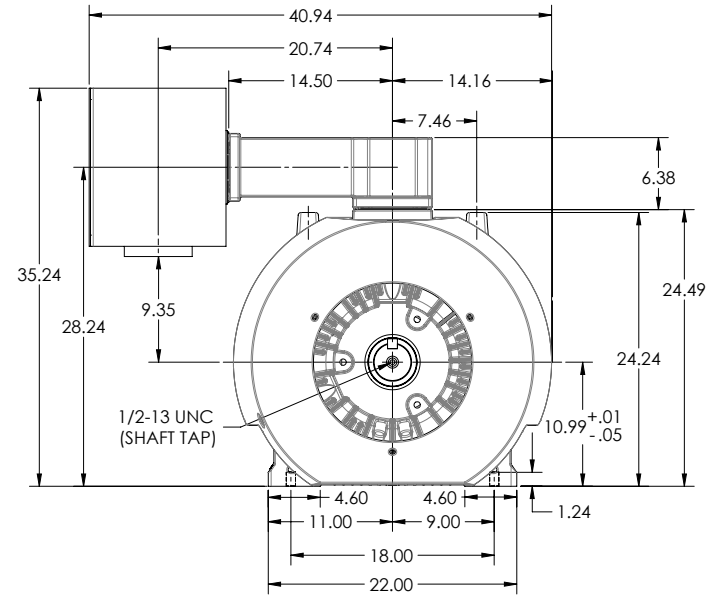
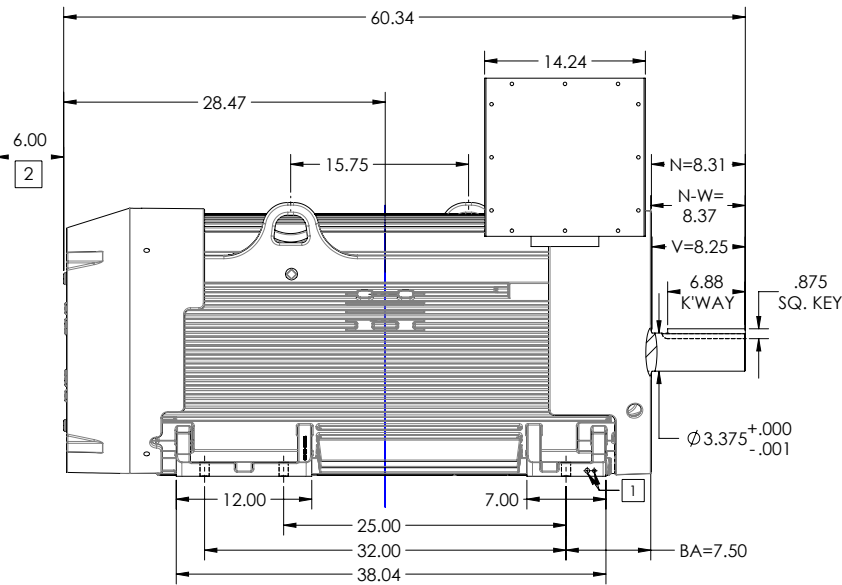

- 1. GROUND HOLES QTY 1 1/2-13 TAP; QTY 1 3/8-16 TAP
- 2. OBSTRUCTION MUST NO ENCR OACH ON AIR INLET

CONDUIT BOX LOCATED ON OPPOSITE SIDE WHEN F-2.
IF MOUNTING CLEARANCE DETAILS ARE REQUIRED, CONSULT FACTORY.
MAXIMUM PERMISSIBLE SHAFT RUNOUT WHEN MEASURED AT END OF
STANDARD SHAFT EXTENSION IS .003" T.I.R. TO 5 INCH DIA.

DIMENSIONS ARE IN INCHES; SEE SHEET 2 FOR DIMENSIONS IN MILLIMETERS.
WEIGHT (LBS): 3875, MOTOR WEIGHTS MAY VARY BY 15% DEPENDING ON RATING.
CUSTOMER IS RESPONSIBLE FOR DETERMINING THAT MOTOR PERFORMANCE IS SUITABLE IN THE APPLICATION.

REV. DESC: 970613: UPDATED WITH NEW C/BOX AND SHAFT			
REV: B	VERSION: 02	REVISED: 10-50-56 03/14/2016	TDR: 00000970613
MODEL NO. 617423-006			REF: -
BY: USJEDIL	Material: -		

BALDOR

DIM SHEET GL449T-449T FOOT MOUNTED HORIZONTAL

900-237219

617423-006

DUTY MASTER ALTERNATING CURRENT MOTORS
SQUIRREL-CAGE INDUCTION

617423-006

ENCLOSURE: TOTALLY ENCLOSED
MOUNTING: FOOT, F-1

GL449T/G449T FRAME MOUNTING HOLES

COOLING: FAN COOLED

OVERSIZED 14X14X12 STEEL BOX

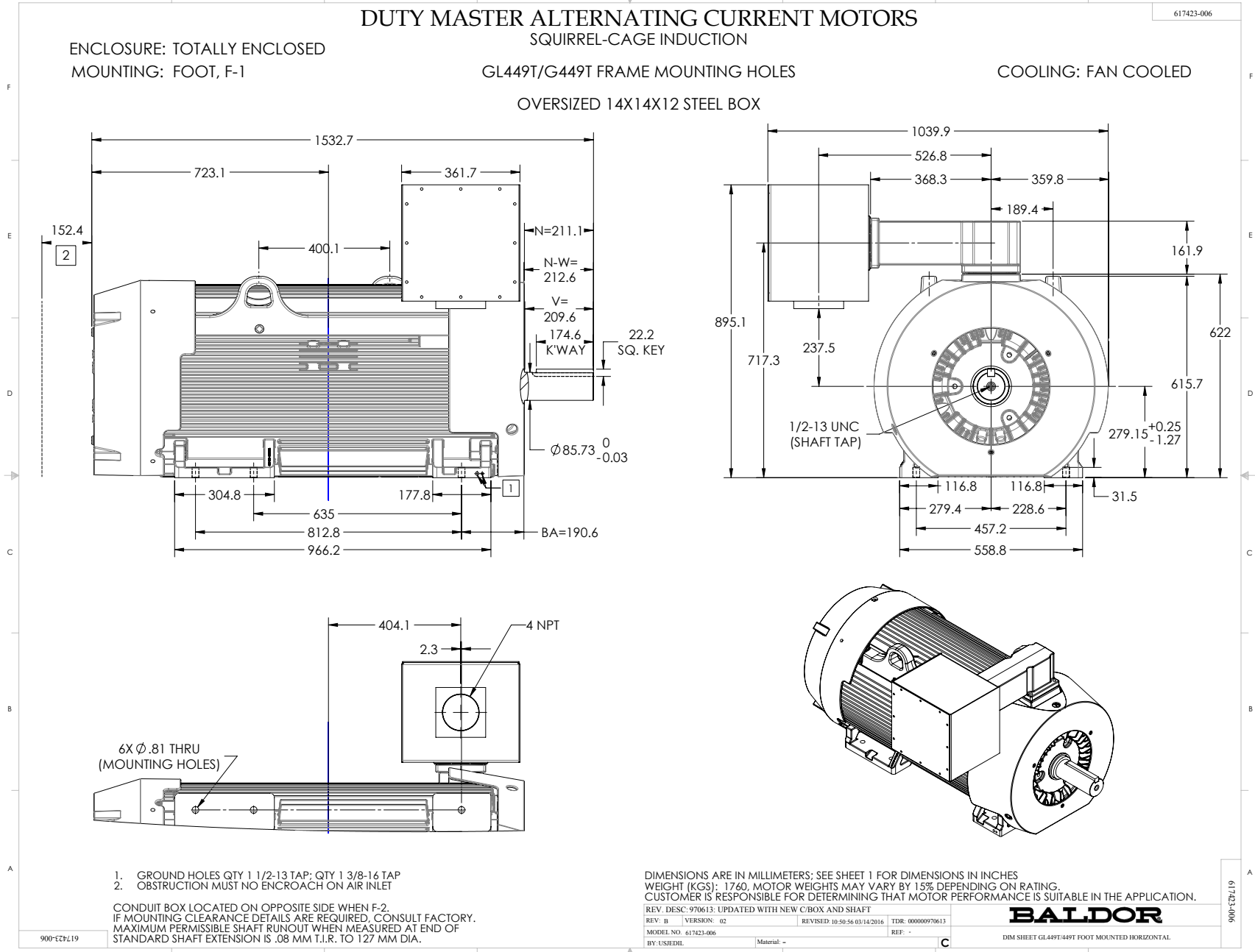

416820-036

A-C MOTOR
CONNECTION DIAGRAM
STANDARD 3 LEAD CONNECTED



(N.P. 1575-BA)

416820-036

REV. DESC: LOADED TO BUS, C/R 335225		
REV. LTR: -	VERSION: 00	TDR: 000000538207
FILE: \MGA\00000\682	REVISED: 11:54:06 04/30/2010	
MTL: -	BY: RAGRA	

BALDOR

CONN DIAG - STANDARD 3 LEAD
SH 1 of 1