

BALDOR® • RELIANCE 

Product Information Packet

ECP64110TR-4

40HP,1770RPM,3PH,60HZ,324T,1260M,TEFC,F1

Part Detail							
Revision:	N	Status:	PRD/A	Change #:		Proprietary:	No
Type:	AC	Elec. Spec:	12WGY762	CD Diagram:	CD0006	Mfg Plant:	
Mech. Spec:	12G908	Layout:	12LYG908	Poles:	04	Created Date:	09-18-2014
Base:	RG	Eff. Date:	11-17-2020	Leads:	3#8		

Specs			
Catalog Number:	ECP64110TR-4	Insulation Class:	F
Enclosure:	TEFC	Inverter Code:	Inverter Duty
Frame:	324T	KVA Code:	F
Frame Material:	Iron	Lifting Lugs:	Standard Lifting Lugs
Output @ Frequency:	40.000 HP @ 60 HZ	Locked Bearing Indicator:	Locked Bearing
Synchronous Speed @ Frequency:	1800 RPM @ 60 HZ	Motor Lead Quantity/Wire Size:	3 @ 8 AWG
Voltage @ Frequency:	460.0 V @ 60 HZ	Motor Lead Exit:	Ko Box
XP Class and Group:	CLI GP A,B,C,D	Motor Lead Termination:	Ring Terminals
XP Division:	Division II	Motor Type:	1260M
Agency Approvals:	CSA	Mounting Arrangement:	F1
	CSA EEV	Power Factor:	86
	UR	Product Family:	Chem Process S/P 32-8 IEEE 841
Auxillary Box:	No Auxillary Box	Pulley End Bearing Type:	Roller
Auxillary Box Lead Termination:	None	Pulley Face Code:	Standard
Base Indicator:	Rigid	Pulley Shaft Indicator:	Standard
Bearing Grease Type:	Mobilith SHC220, HC9455	Rodent Screen:	None
Blower:	None	Shaft Extension Location:	Pulley End
Constant Torque Speed Range:	1	Shaft Ground Indicator:	No Shaft Grounding

Current @ Voltage:	46.000 A @ 460.0 V	Shaft Rotation:	Reversible
Design Code:	B	Shaft Slinger Indicator:	No Slinger
Drip Cover:	No Drip Cover	Speed Code:	Single Speed
Duty Rating:	CONT	Motor Standards:	NEMA
Electrically Isolated Bearing:	Not Electrically Isolated	Starting Method:	Direct on line
Enclosure Modification:	661	Thermal Device - Bearing:	None
Feedback Device:	NO FEEDBACK	Thermal Device - Winding:	None
Front Face Code:	Standard	Vibration Sensor Indicator:	No Vibration Sensor
Front Shaft Indicator:	None	Winding Thermal 1:	None
Heater Indicator:	No Heater	Winding Thermal 2:	None
		XP Temp Code:	T3

Nameplate NP3201											
STK.NO.	ECP64110TR-4	P/N		ENCL	TEFC						
SPEC.	12G908Y762G1	CC	010A	FRAME	324T	S/N					
HP	40	CLASS	F	HZ	60	ODE BRG	6312	DE BRG	NU312		
RPM	1770	RPM MAX	2700	PH	3	DES	B	D.E. BRG.	60RU03X30X		
VOLT	460	CODE	F	O.D.E. BRG.	60BC03X30X						
AMP	46	MOTOR WEIGHT	600	GREASE	MOBILITH SHC220						
RATING	40C AMB-CONT	MAX. KVAR	8.3	BLANK	AIR COOLED HEAT						
NEMA-NOM-EFF	94.1	# OF ROTOR BARS	40	SER.F.	1.15	IP	56	EXCHANGER MTR			
G.MIN.EFF	93	# OF STATOR SLOTS	48	PF	86	INV.TYPE	PWM				
TEMP CODE	T3	INVERTER-TEMP-CODE	200								
TEMP =	200	C HP FR	60	C HP TO	90						
CT HZ FROM	1	CT HZ TO	60								
HTR-VOLTS		HTR-AMPS		HTR-WATTS		MAX. SPACE HEATER TEMP.		VT HZ FROM	0	VT HZ TO	60

Parts List		
Part Number	Description	Quantity
SA287146	SA 12G908Y762G1	1.000 EA
RA273362	RA 12G908Y762G1	1.000 EA
09FN3001C03	EXTERNAL FAN, PLASTIC (COMES W/SCREW FRO	1.000 EA
WD1000B19	TERMINAL BURNDY L250HP	1.000 EA
10XN3816K08	3/8-16 X .50 HEX HD CAP SCREW GRADE 5	1.000 EA
10CB1000A04P	KO BOX, MACH W/2.00 NPT W/EPOXY PRIMER	1.000 EA
09GS1010	GASKET, DWG, LEADWIRE SEPERATOR	1.000 EA
10XN3118K16	5/16-18 X 1' GRADE #5, STL, ZINC PLATE	4.000 EA
HW1001A31	LOCKWASHER 5/16, ZINC PLT.591 OD, .319 I	4.000 EA
WD1000B16	T&B CX70TN OR L70P TERMINAL LUG	1.000 EA
10XN2520K06	1/4-20 X 3/8" HX HD SCREWGRADE 5, ZINC P	1.000 EA
HW1001A25	LOCKWASHER 1/4, ZINC PLT .493 OD, .255 I	1.000 EA
HA3400A32	STUD, 1/2-13 X 7.38	4.000 EA
HW1001A50	LOCKWASHER 1/2, ZINC PLT.,.879 OD, .509 I	4.000 EA
HA4002A03	#304 S.S. DRAIN FITTING, .125 NPT (.44 H	1.000 EA
HA4002A03	#304 S.S. DRAIN FITTING, .125 NPT (.44 H	1.000 EA
HW4500A20	1/8NPT SL PIPE PLUG	1.000 EA
HA4017A01	1/8 X 4 GREASE EXT (F/S)	1.000 EA
HA4017A11	1/8 X 2.75 GREASE EXT (F/S)	1.000 EA
HW4019A01	PIPE COUPLING 1/8 NPT,STEEL,ZINC COATING	1.000 EA
HW4601A55	INPRO/SEAL #1698-A-M0022-0 VBXX 312 BRG/	1.000 EA
10XN3118K40	5/16-18 X 2.50" HEX HD, GRADE 5	4.000 EA
HW4600G55	DOME SLINGER, 7.125 OD X 2.120/2.060 ID	1.000 EA
12EP1111A01P	SPL PUEP 312 BRG FOR INPRO SEAL W/EPOXY	1.000 EA

Parts List (continued)		
Part Number	Description	Quantity
HW4500A20	1/8NPT SL PIPE PLUG	1.000 EA
10XN5013K28	1/2-13 X 1.75 HEX HEAD MACH SCREW,GRAD	4.000 EA
HW1001A50	LOCKWASHER 1/2, ZINC PLT.,.879 OD, .509 I	4.000 EA
HW4601A55	INPRO/SEAL #1698-A-M0022-0 VBXX 312 BRG/	1.000 EA
10XN3118K40	5/16-18 X 2.50" HEX HD, GRADE 5	4.000 EA
WD4100A85	HEYCO #2790 DOME PLUG,DP-2500, FOR 2.50	1.000 EA
XY5013A12	NUT,1/2-13,HEX,STEEL,ZINCPLATED	4.000 EA
HW1001A50	LOCKWASHER 1/2, ZINC PLT.,.879 OD, .509 I	4.000 EA
10CB1503A01P	CONDUIT BOX LIPPED LID, MACH W/EPXY PRMR	1.000 EA
14GS1003	GASKET CONDUIT BOX LID, NEOP	1.000 EA
10XN2520K16	1/4-20 X 1" HX HD SCRW GRADE 5, ZINC P	4.000 EA
HW1001A25	LOCKWASHER 1/4, ZINC PLT .493 OD, .255 I	4.000 EA
MJ5004A59	ADHESIVE LOCTITE #401 SURFACE INSENSITIV	0.010 EA
HW2501H33	KEY, 1/2 SQ X 3.875	1.000 EA
MJ5001A27	32220KN GRAY SEALER *MIN BUY 4 QTS=1GAL	0.031 QT
MJ5002A01	SILICON RUBBER SEALANT, 732CL 10.3 OZ TU	0.025 EA
MJ5002A01	SILICON RUBBER SEALANT, 732CL 10.3 OZ TU	0.029 EA
LB1115N	LABEL,LIFTING DEVICE (ON ROLLS)	1.000 EA
WD1000B48	T&B D73, RING TERMINAL 8 AWG 3/8 STUD	3.000 EA
12EP1111A03GP6	FR ENDPLATE, MACH W/EPOXY PRIMER & PAINT	1.000 EA
HW4500A21	1618BALEMITE FITTING 825 UNIVERSAL	1.000 EA
HA4051A00	PLASTIC CAP FOR GREASE FITTING	1.000 EA
HW4500A17	317400 ALEMITE GREASE RELIEF	1.000 EA
MJ1000A62	GREASE - MOBILITH SHC220, HC9455	0.200 LB

Product Information Packet: ECP64110TR-4 - 40HP,1770RPM,3PH,60HZ,324T,1260M,TEFC,F1

HW4500A03	GREASE FITTING, .125 NPT 1610(ALEMITE) 8	1.000 EA
HA4051A00	PLASTIC CAP FOR GREASE FITTING	1.000 EA
HW4500A17	317400 ALEMITE GREASE RELIEF	1.000 EA
HW2500A25	WOODRUFF KEY USA #1008 #BLOW CARBON STEE	1.000 EA
12FH1002A26GP6	FAN COVER, MACH W/EPOXY PRIMER	1.000 EA
MG1025N19	WILKOFASST, 778.50, RELIANCE BLUE-GREEN	0.080 GA
85XU0407S04	4X1/4 U DRIVE PIN STAINLESS	4.000 EA
LB1449	DIV-2/NEC WARNING LABEL	1.000 EA
LB1119N	WARNING LABEL	1.000 EA
LC0006	CONNECTION LABEL	1.000 EA
NP3201	SS 841/661XL INV DIV-2 UL CSA- C US EEV	1.000 EA
10PA1010	PACKAGING GROUP, PRINT PK1151A06	1.000 EA
12PA1075	PKGP SHAFT TENSIONER 2X4 LEG 6 OPEN 5	1.000 EA
10XN6311K40	5/8-11 X 2.50 LG HEX HD. CAP SCR,GR.5,ZI	1.000 EA
HW1000A38	WASHER, 3/8" FLAT, SAE Z/P	1.000 EA
MN416A01	TAG-INSTAL-MAINT no wire (2100/bx) 4/22	1.000 EA

AC Induction Motor Performance Data

Record # 92877

Typical performance - not guaranteed values

Winding: 12WGY762-R001		Type: 1260M	Enclosure: TEFC
Nameplate Data		460 V, 60 Hz: Single Voltage Motor	
Rated Output (HP)	40	Full Load Torque	118 LB-FT
Volts	460	Start Configuration	direct on line
Full Load Amps	46	Breakdown Torque	305 LB-FT
R.P.M.	1770	Pull-up Torque	146 LB-FT
Hz	60 Phase	Locked-rotor Torque	173 LB-FT
NEMA Design Code	B KVA Code	Starting Current	290 A
Service Factor (S.F.)	1.15	No-load Current	14.3 A
NEMA Nom. Eff.	94.1 Power Factor	Line-line Res. @ 25°C	0.16401 Ω
Rating - Duty	40C AMB-CONT	Temp. Rise @ Rated Load	62°C
S.F. Amps		Temp. Rise @ S.F. Load	78°C
		Locked-rotor Power Factor	26.5
		Rotor inertia	7.99 lb-ft ²

Load Characteristics 460 V, 60 Hz, 40 HP

% of Rated Load	25	50	75	100	125	150	S.F.
Power Factor	57	77	84	86	87	86	87
Efficiency	92.6	94.7	94.8	94.1	93.5	92.5	93.8
Speed	1794.1	1788	1780.8	1773.7	1765.2	1756.6	1769
Line amperes	18.1	25.6	35.6	46.1	57.9	70.1	53.2

Performance Graph at 460V, 60Hz, 40.0HP Typical performance - Not guaranteed values

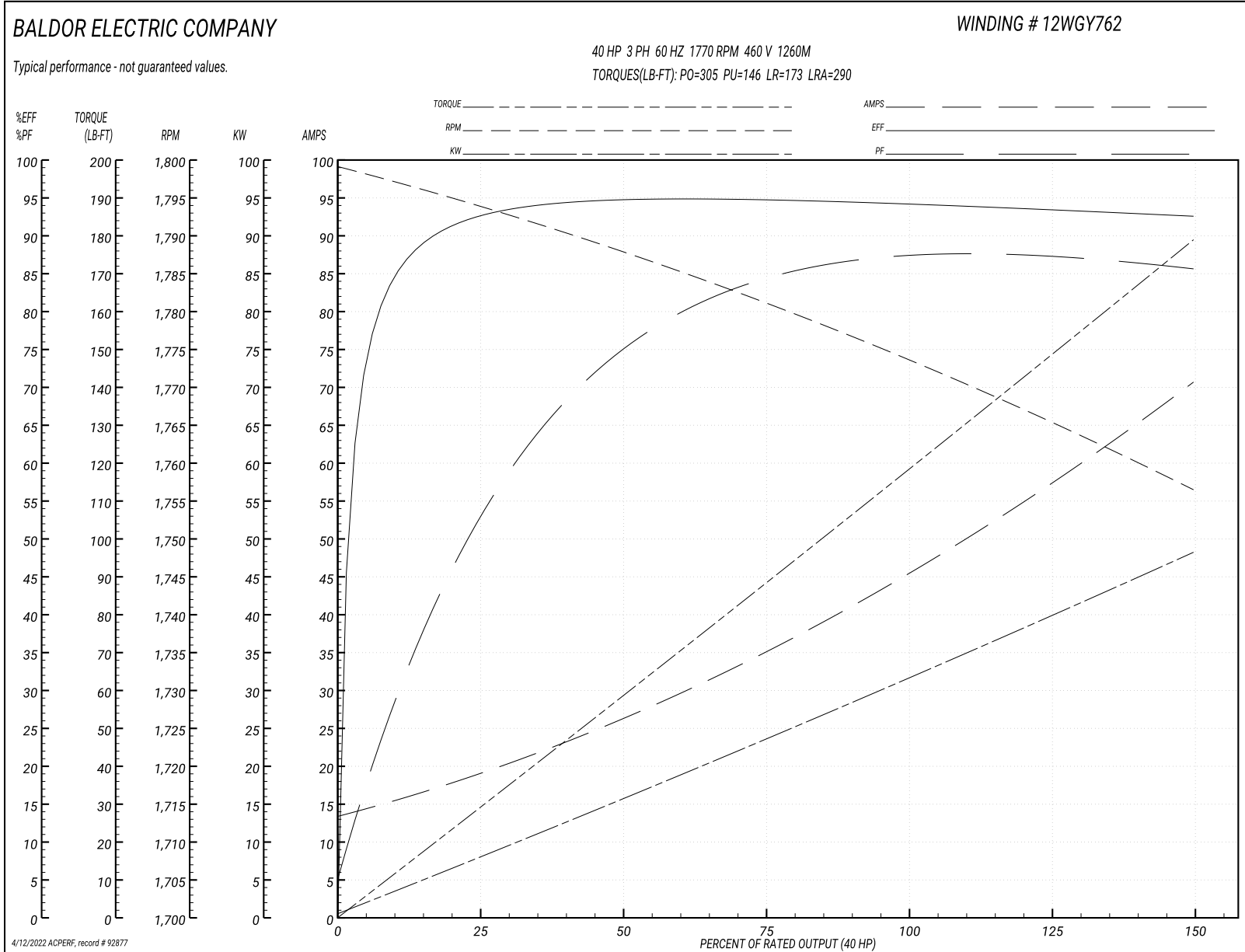

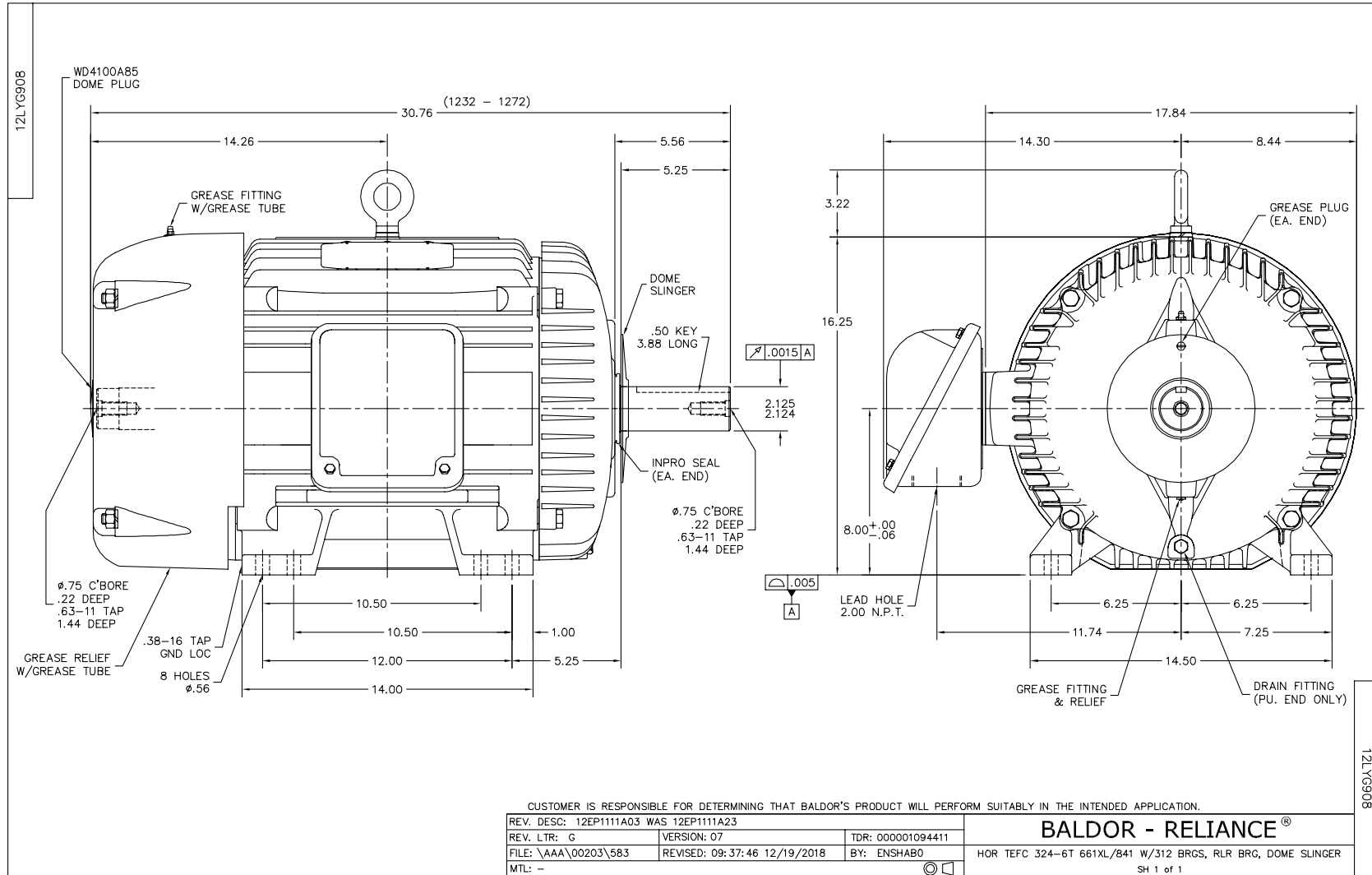

CD0006



NOTES:

1. THREE LEAD MOTOR MAY BE EITHER WYE CONNECTED OR DELTA CONNECTED.
2. INTERCHANGE ANY TWO LINE LEADS TO REVERSE ROTATION.
3. OPTIONAL THERMOSTATS ARE PROVIDED WHEN SPECIFIED.
4. ACTUAL NUMBER OF INTERNAL PARALLEL CIRCUITS MAY VARY.
5. LEAD COLORS ARE OPTIONAL. LEADS MUST BE NUMBERED AS SHOWN.

CD0006

REV. DESC: ADD CLASS CONN00000007		
REV. LTR: E	VERSION: 01	TDR: 000001099922
FILE: \AAA\00005\141	REVISED: 10:24:49 02/19/2019	BY: ENBRIRO
MTL: -		

BALDOR - RELIANCE®

3PH, SV, 3 LEADS, WYE OR DELTA CONNECTED

SH 1 of 1