



Customer information packet

ECP84400TR-4

100HP, 1785RPM, 3PH, 60HZ, 405T, TEFC, FOOT,
Class - CLI GP A,B,C,D
Division - Division II

Specifications

Enclosure	TEFC
Frame	405T
Frame Material	Iron
Frequency	60.00 Hz
Motor Letter Type	Three Phase
Output @ Frequency	100.000 HP @ 60 HZ
Phase	3
Synchronous Speed @ Frequency	1800 RPM @ 60 HZ
Voltage @ Frequency	460.0 V @ 60 HZ
XP Class and Group	CLI GP A,B,C,D
XP Division	Division II
Agency Approvals	CCSA US NEMA PREMIUM UR
Ambient Temperature	40 °C
Auxillary Box	No Auxillary Box
Base Indicator	Rigid
Bearing Grease Type	Mobil SHC 220 (Athens Only)
Constant Torque Speed Range	10-60
Current @ Voltage	112.000 A @ 460.0 V
Design Code	B
Drip Cover	No Drip Cover
Duty Rating	CONT
Efficiency @ 100% Load	95.4 %
Enclosure Modification	841
Feedback Device	NO FEEDBACK
Heater Indicator	No Heater
High Voltage Full Load Amps	112.0 a
Insulation Class	F
Inverter Code	Inverter Ready
IP Rating	IP56
KVA Code	G

Part detail

Revision	F
Type	AC
Mech. spec.	
Base	
Status	PRD/A
Elec. spec.	A40WG0028
Layout	617429-818
Eff. date	02-28-2022
CD Diagram	416820-036
Poles	04
Leads	3#2
Proprietary	False
Created date	08-06-2019

Lifting Lugs	Standard Lifting Lugs
Motor Lead Quantity/Wire Size	3 @ 2 AWG
Motor Standards	None
Motor Type	A40064M
Mounting Arrangement	F1
No Load Current	29.2 a
Number of Poles	4
Overall Length	38.20 IN
Power Factor	87
Pulley End Bearing Type	Roller
Pulley Face Code	Standard
Service Factor	1.15
Shaft Diameter	2.875 IN
Shaft Ground Indicator	No Shaft Grounding
Shaft Rotation	Reversible
Shaft Slinger Indicator	No Slinger
Speed	1785 rpm
Speed Code	Single Speed
Starting Method	Direct on line
Thermal Device - Bearing	None
Thermal Device - Winding	None
XP Temp Code	T2D

Nameplate

NP3237

CAT NO	ECP84400TR-4	SPEC NO.	A40-8211-0028						
HP	100	AMPS	112	VOLTS	460	DESIGN	B		
FRAME SIZE	405T	RPM	1785	HZ	60	AMB	40	SF	1.15
D.E. BRG.DATA	NU316	O.D.E. BRG.DATA	6316	PH	3	DUTY	CONT	INSUL.CLASS	F
D.E. BRG.	80RUO3M30X	TYPE P	P	ENCL	TEFC	CODE	G		
O.D.E. BRG.	80BC03J30X	POWER FACTOR	87	NEMA-NOM-EFFICIENCY	95.4				
3/4 LOAD EFF.	95.7	IP	56	MAX CORR KVAR	18	GUARANTEED EFFICIENCY	94.5		
TEMP CODE	T3	TEMP =	200						
CHP HZ	60-90	CT HZ	0.6-60	VT HZ	0-60				
INVERTER-TEMP-CODE	T3								
SER.NO.		MOTOR WEIGHT	1326						

000613007EX

CAT NO	ECP84400TR-4	SPEC NO.	A40-8211-0028	
NO. ROTOR BARS	47	GREASE TYPE	MOBIL SHC 220	
NO. SLOTS	60	NL AMPS AT RATED VOLTAGE	29.2	
5 YEAR WARRANTY		WINDING RES @25 C	.04930	OHMS
MFG. DATE		SER.NO		
	SFA 128			

Parts list

Part number	Description	Quantity
SA374110	SA A40-8211-0028	1.000 ea
RA363941	RA A40-8211-0028	1.000 ea
000692000RT	N/P	1.000 ea
034001016AB	WSHR .562ID 1.375OD .109	1.000 ea
034001014AB	FLAT WASHER 3/8"PLATED	1.000 ea
NP3237	SS SUPER E INVERTER DUTY IEEE 841	1.000 ea
000613007EX	SS IEEE 841 EMBOSSED AUXILIARY NAMEPLATE	1.000 ea
415070001A	RUBBER MOUNT 3X3X1 THICK	1.000 ea
000692000FF	N/P	1.000 ea
000692000JP	N/P	1.000 ea
032018024CK	HHCS 3/8-16X3 PLTD.	1.000 ea
604797013R	447 FR. ROLLER BEARING MOTOR SHAFT	1.000 ea
000692000VD	LABEL WARNING	1.000 ea
604799003C	PLASTIC BAG 42X32X46	1.000 ea
000692000VH	N/P (RELEASE 1000 PCS)	1.000 ea
033300014AC	HEX NUT, SHIPPING - 400	2.000 ea
034001016AB	WSHR .562ID 1.375OD .109	2.000 ea
034001014AB	FLAT WASHER 3/8"PLATED	2.000 ea
032510024D	CARRIAGE BOLT - 444	2.000 ea
604797045	STD. 400 FRAME SKID	1.000 ea
004824015AP	GREASE MOBILITH SHC 220	0.884 lb
032018008CK	HHCS 3/8-16X1L PLATED	4.000 ea
032018020EK	HHCS 5/8-11X2-1/2 PLTD.	4.000 ea
032018024CK	HHCS 3/8-16X3 PLTD.	3.000 ea
034000014AB	WSH ID.406 OD.812 TH.065	4.000 ea
034180008DA	KEY 1/4X1/4X1 L (shipping)	1.000 ea
034530056BB	P/NIP 1/4X7 SCHED 40	1.000 ea
034530052AB	P/NIP 1/8X6-1/2 Zinc	1.000 ea
034631002AB	BUSH 1/4 TO 1/8 PLTD.	1.000 ea
035000001G	GREASE RELIEF FITTING, ALEMITE 317400	1.000 ea
078548001R	FAN KB 234/150 (84) 400	1.000 ea

083198101A	G400 STD FAN COVER MACHINING	1.000 ea
089412501C	G400 MACH 6316 FT MT BRKT 089412500WCA	1.000 ea
415028079G	INPRO SEAL,.625 WIDE,316 BRG	1.000 ea
415072001B	CLAMP	1.000 ea
415096002A	CPLG 1/8 HEX TYPE	1.000 ea
423709011C	WASHER	3.000 ea
032018020EK	HHCS 5/8-11X2-1/2 PLTD.	4.000 ea
032018024CK	HHCS 3/8-16X3 PLTD.	3.000 ea
034530040AB	P/NIP 1/8X5 GALV.	1.000 ea
034530040BB	P/NIP 1/4X5	1.000 ea
034631002AB	BUSH 1/4 TO 1/8 PLTD.	1.000 ea
035000001G	GREASE RELIEF FITTING, ALEMITE 317400	1.000 ea
089412501C	G400 MACH 6316 FT MT BRKT 089412500WCA	1.000 ea
415028079G	INPRO SEAL,.625 WIDE,316 BRG	1.000 ea
415096002A	CPLG 1/8 HEX TYPE	1.000 ea
423709011C	WASHER	3.000 ea
032018010CK	HHCS 3/8-16X1-1/4 PLTD. 032018010CR	4.000 ea
033512008LB	HHTTS 1/4-20X1 PLATED	4.000 ea
034000014AB	WSH ID.406 OD.812 TH.065	4.000 ea
035000001A	ALFTG 1/8" 1610-BL	1.000 ea
035000001A	ALFTG 1/8" 1610-BL	1.000 ea
067053000B	GASK 320-400	1.000 ea
076708000BB	CONDUIT BOX-360	1.000 ea
076709000A	C/B Cover - 360	1.000 ea
406099000A	PLUG - FAN COVER 320-440	1.000 ea
415000115H	T/LUG #2AWG-4/0AWG	1.000 ea
415039016A	TERBD, 360-400	1.000 ea
418150003A	GREASE FITTING CAP	1.000 ea
418150003A	GREASE FITTING CAP	1.000 ea
033775004EA	DRSCR #6-1/4 304 S.S.	4.000 ea
034180044JA	KEY 3/4X3/4X5-1/2 L	1.000 ea
MG1025N19	WILKO 778.50 BLUE GREEN - 55 GAL DRUMS	0.375 ga
004824003CBY	WILKO PAINT 060.02 - ACTIVATOR	0.063 ga
421948051	LABEL, MYLAR	1.000 ea

000613006PU	N/P (RELEASE QTY 10,000) UL CSA LABEL	1.000 ea
LB1449	DIV-2/NEC WARNING LABEL	1.000 ea
032018005DL	1/2-13 X 5/8 SILICON BRONZE HHCS	1.000 ea
412118006A	DRAIN	2.000 ea

617429-818

DUTY MASTER ALTERNATING CURRENT MOTORS
SQUIRREL-CAGE INDUCTION

ENCLOSURE: TOTALLY ENCLOSED

COOLING: FAN COOLED

MOUNTING: FOOT, F-1

G405T/G404T FRAME MOUNTING HOLES

ENCLOSURE ENHANCEMENT: 841-XL

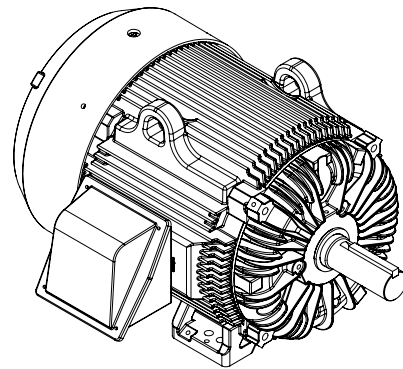
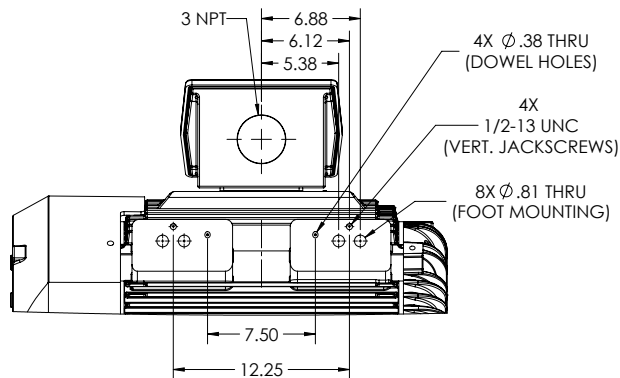
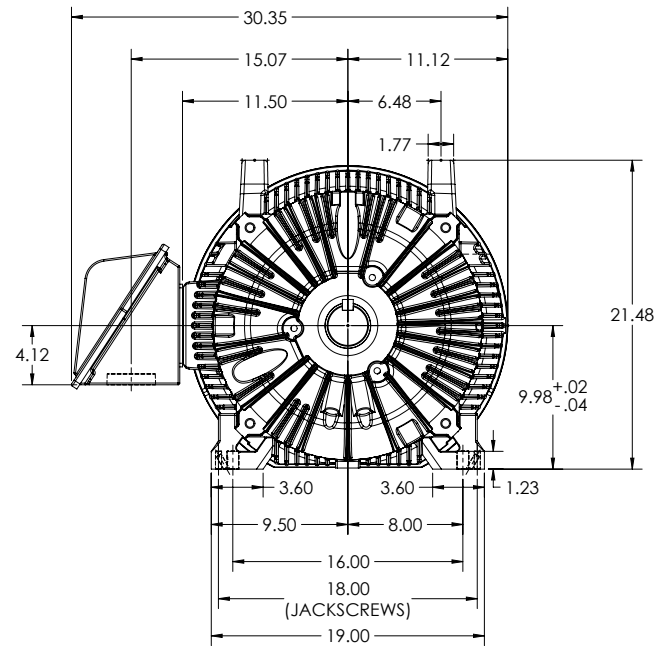
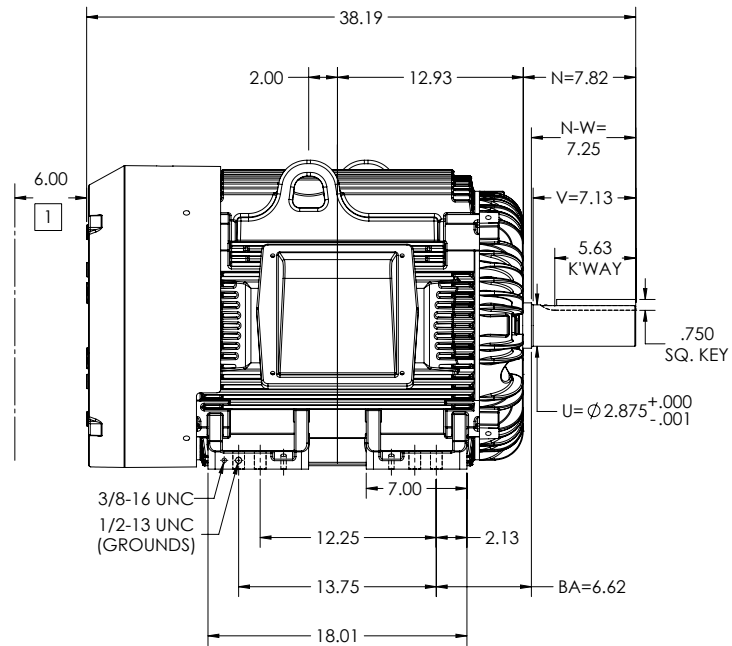

DIMENSIONS ARE IN INCHES.
MOTOR WEIGHT (LBS) = 1350 ± 15% DEPENDING ON RATING.
CUSTOMER IS RESPONSIBLE FOR DETERMINING THAT MOTOR PERFORMANCE IS SUITABLE IN THE APPLICATION.

SHEET NUMBER
1 OF 2

1 OBSTRUCTION MUST NOT ENCR OACH ON AIR INLET.

IF MOUNTING CLEARANCE DETAILS ARE REQUIRED, CONSULT FACTORY.
MAX PERMISSIBLE SHAFT RUNOUT IS .0015 T.I.R. FOR BALL & .002 T.I.R. FOR ROLLER BEARING.

REV. DESC-CORRECT WEIGHT ON DS 2			
REV: E	VERSION: 05	REVISED: 11-12-45 03/21/2022	TDR: 000001187880
MODEL NO. 617429-818		REF:	
BY: USJEDIL	Material:	C	

BALDOR

G405-404T TEFC F1 FOOT CAST IRON BOX 841-XL

617429-818

617429-818

DUTY MASTER ALTERNATING CURRENT MOTORS
SQUIRREL-CAGE INDUCTION

ENCLOSURE: TOTALLY ENCLOSED

COOLING: FAN COOLED

MOUNTING: FOOT, F-1

G405T/G404T FRAME MOUNTING HOLES

ENCLOSURE ENHANCEMENT: 841-XL

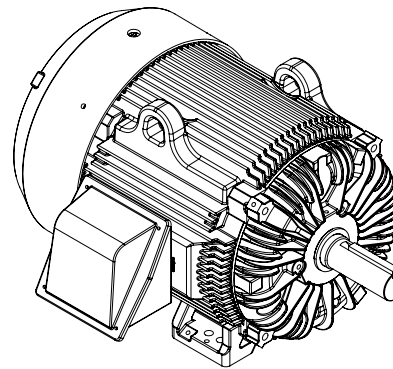
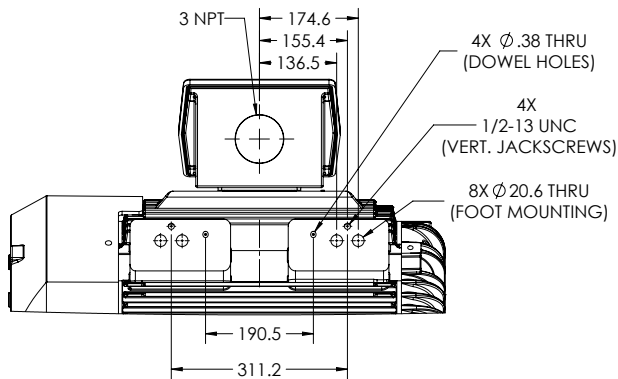
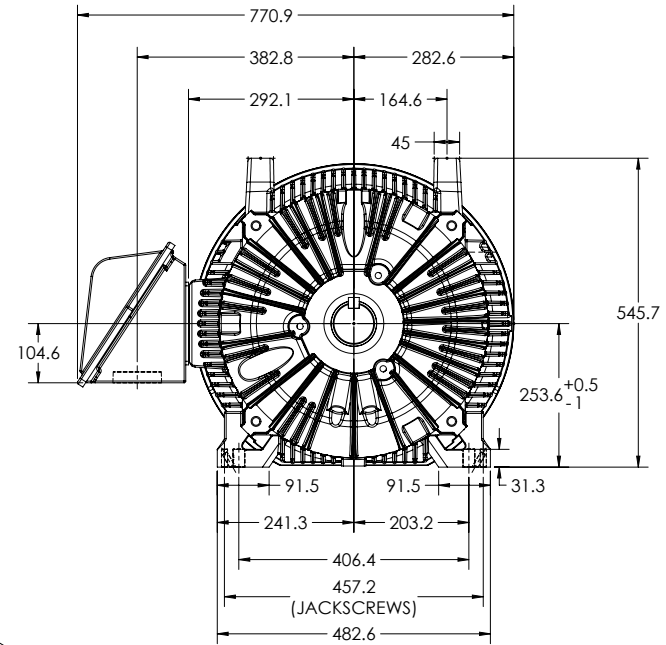
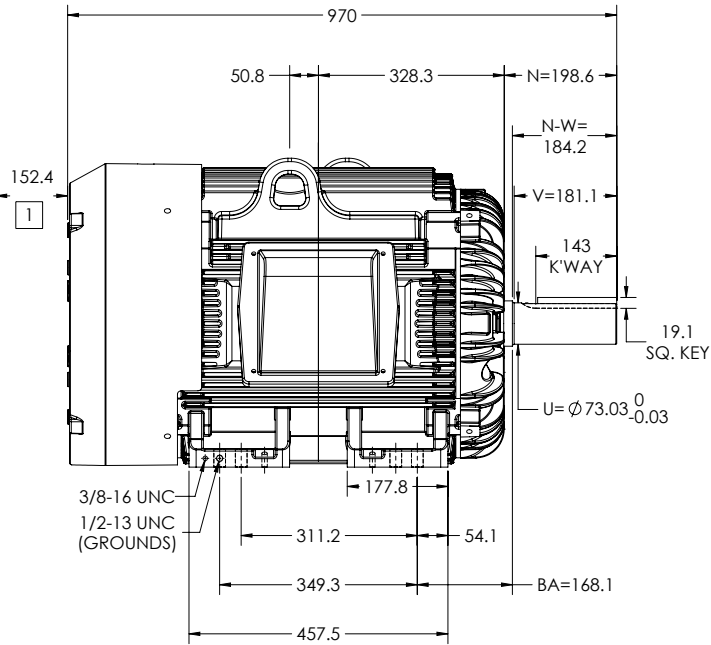

DIMENSIONS ARE IN MILLIMETERS.
MOTOR WEIGHT (KG) = 612 ± 15% DEPENDING ON RATING.
CUSTOMER IS RESPONSIBLE FOR DETERMINING THAT MOTOR PERFORMANCE IS SUITABLE IN THE APPLICATION.

SHEET NUMBER
2 OF 2

1 OBSTRUCTION MUST NOT ENCR OACH ON AIR INLET.

IF MOUNTING CLEARANCE DETAILS ARE REQUIRED, CONSULT FACTORY.
MAX PERMISSIBLE SHAFT RUNOUT IS .04 T.I.R. FOR BALL & .05 T.I.R. FOR ROLLER BEARING.

REV. DESC: CORRECT WEIGHT ON DS 2			
REV: E	VERSION: 05	REVISED: 11-12-45 03/21/2022	TDR: 00001187880
MODEL NO. 617429-818		REF:	
BY: USJEDIL	Material:	C	

BALDOR

G405-404T TEFC F1 FOOT CAST IRON BOX 841-XL

617429-818

416820-036

A-C MOTOR
CONNECTION DIAGRAM
STANDARD 3 LEAD CONNECTED



(N.P. 1575-BA)

416820-036

REV. DESC: LOADED TO BUS, C/R 335225		
REV. LTR: -	VERSION: 00	TDR: 000000538207
FILE: \MGA\00000\682	REVISED: 11: 54: 06 04/30/2010	
MTL: -	BY: RAGRA	

BALDOR

CONN DIAG - STANDARD 3 LEAD
SH 1 of 1