



Customer information packet

ECP844156TR-5

150HP, 1190RPM, 3PH, 60HZ, 447T, TEFC, FOOT,
Class - CLI GP A,B,C,D
Division - Division II

Specifications

Enclosure	TEFC
Frame	447T
Frame Material	Iron
Frequency	60.00 Hz
Motor Letter Type	Three Phase
Output @ Frequency	150.000 HP @ 60 HZ
Phase	3
Synchronous Speed @ Frequency	1200 RPM @ 60 HZ
Voltage @ Frequency	575.0 V @ 60 HZ
XP Class and Group	CLI GP A,B,C,D
XP Division	Division II
Agency Approvals	CCSA US NEMA PREMIUM UR
Ambient Temperature	40 °C
Auxillary Box	No Auxillary Box
Base Indicator	Rigid
Bearing Grease Type	Mobil SHC 220 (Athens Only)
Constant Torque Speed Range	15-60
Current @ Voltage	136.000 A @ 575.0 V
Design Code	B
Drip Cover	No Drip Cover
Duty Rating	CONT
Efficiency @ 100% Load	95.8 %
Enclosure Modification	841
Feedback Device	NO FEEDBACK
Heater Indicator	No Heater
High Voltage Full Load Amps	136.0 a
Insulation Class	F
Inverter Code	Inverter Ready
IP Rating	IP56
KVA Code	F

Part detail

Revision	E
Type	AC
Mech. spec.	
Base	
Status	PRD/A
Elec. spec.	A44WG1357
Layout	617434-663
Eff. date	04-08-2021
CD Diagram	416820-036
Poles	06
Leads	3#1
Proprietary	False
Created date	12-11-2018

Lifting Lugs	No Lifting Lugs
Motor Lead Quantity/Wire Size	3 @ 1 AWG
Motor Standards	Other
Motor Type	A44120M
Mounting Arrangement	F1
No Load Current	34.0 a
Number of Poles	6
Overall Length	48.46 IN
Power Factor	86
Pulley End Bearing Type	Roller
Pulley Face Code	Standard
Service Factor	1.15
Shaft Diameter	3.375 IN
Shaft Ground Indicator	No Shaft Grounding
Shaft Rotation	Phase Seq-Std Rot (CCWODE)
Shaft Slinger Indicator	No Slinger
Speed	1190 rpm
Speed Code	Single Speed
Starting Method	Direct on line
Thermal Device - Bearing	None
Thermal Device - Winding	None
XP Temp Code	T3

Nameplate

NP3237

CAT NO	ECP844156TR-5	SPEC NO.	A44-7002-1357						
HP	150	AMPS	136	VOLTS	575	DESIGN	B		
FRAME SIZE	447T	RPM	1190	HZ	60	AMB	40	SF	1.15
D.E. BRG.DATA	NU222	O.D.E. BRG.DATA	6318	PH	3	DUTY	CONT	INSUL.CLASS	F
D.E. BRG.	110RU02M30X	TYPE P	P	ENCL	TEFC	CODE	F		
O.D.E. BRG.	90BC03J30X	POWER FACTOR	86	NEMA-NOM-EFFICIENCY	95.8				
3/4 LOAD EFF.	96.2	IP	56	MAX CORR KVAR	25.0	GUARANTEED EFFICIENCY	95		
TEMP CODE	T3	TEMP =	200						
CHP HZ	60-90	CT HZ	15-60	VT HZ	0-60				
INVERTER-TEMP-CODE	T3								
SER.NO.		MOTOR WEIGHT	2595						

000613007EX

CAT NO	ECP844156TR-5	SPEC NO.	A44-7002-1357	
NO. ROTOR BARS	71	GREASE TYPE	MOBIL SHC 220	
NO. SLOTS	90	NL AMPS AT RATED VOLTAGE	34.0	
5 YEAR WARRANTY		WINDING RES @25 C	.0507	OHMS
MFG. DATE		SER.NO		

NP2496L

MOBIL SHC -220 GREASE

Parts list

Part number	Description	Quantity
SA364344	SA A44-7002-1357	1.000 ea
RA353668	RA A44-7002-1357	1.000 ea
000613006PU	N/P (RELEASE QTY 10,000) UL CSA LABEL	1.000 ea
NP3237	SS SUPER E INVERTER DUTY IEEE 841	1.000 ea
000613007EX	SS IEEE 841 EMBOSSED AUXILIARY NAMEPLATE	1.000 ea
000692000FF	N/P	1.000 ea
000692000JP	N/P	1.000 ea
000692000RT	N/P	1.000 ea
000692000VD	LABEL WARNING	1.000 ea
NP2496L	MOTOR LUBE NAMEPLATE	1.000 ea
004824015AP	GREASE MOBILITH SHC 220	1.156 lb
032018008CK	HHCS 3/8-16X1L PLATED	4.000 ea
032018020FK	HHCS 3/4-10X2-1/2 PLTD.	4.000 ea
032018030DK	HHCS 1/2-13X3-3/4 PLTD.	3.000 ea
032620016LA	SOCKET SET SCREW-449	3.000 ea
034017014AB	LCKW 3/8 STD. PLATED	4.000 ea
034180014DA	KEY 1/4X1/4X1-3/4 L	1.000 ea
034530064AB	P/NIP 1/8 X 8" L Pipe Nipple	1.000 ea
034530064BB	P/NIP 1/4X8 PLATED	1.000 ea
034600001AA	BUSH 1/4TO1/8 BLACK	1.000 ea
034630002AB	CPLG 1/4" PLATED	1.000 ea
034690005AB	PPLG 3/4 PLATED	2.000 ea
035000001G	GREASE RELIEF FITTING, ALEMITE 317400	1.000 ea
078549001DA	FAN 400 078549001F	1.000 ea
083199082RA	G28 SHORT FAN COVER W/BAFFLE ASSEMBLY	1.000 ea
089490099D	G28 BRKT 089490098WCA	1.000 ea
415028079H	INPRO SEAL,.625 WIDE,318 BRG	1.000 ea
415072001B	CLAMP	1.000 ea
415096002A	CPLG 1/8 HEX TYPE	1.000 ea
418151014G	RETAIN RING	1.000 ea
423709011D	WASHER	3.000 ea

032018004BK	HHCS 5/16-18X1/2 PLATED	3.000 ea
032018020FK	HHCS 3/4-10X2-1/2 PLTD.	4.000 ea
032018030DK	HHCS 1/2-13X3-3/4 PLTD.	3.000 ea
034017013AB	LCKW 5/16 STD. PLATED	3.000 ea
415915007G	GASK, LAC	1.000 ft
034530056AB	1/8 X 7 PP NIPPLE	1.000 ea
034530056BB	P/NIP 1/4X7 SCHED 40	1.000 ea
034600001AA	BUSH 1/4TO1/8 BLACK	1.000 ea
034630002AB	CPLG 1/4" PLATED	1.000 ea
035000001G	GREASE RELIEF FITTING, ALEMITE 317400	1.000 ea
089490101C	G28 BRKT 089490100WCA	1.000 ea
702623022A	G28 AIR DEFLECTOR DRIVE END -- PLASTIC	1.000 ea
034001013AB	FLTW BAFFLE	3.000 ea
032018006BK	HHCS 5/16-18X3/4 PLATED	3.000 ea
415028079J	INPRO SEAL,.625 WIDE,222 BRG	1.000 ea
415096002A	CPLG 1/8 HEX TYPE	1.000 ea
418151014H	RETAIN RING	1.000 ea
423709011D	WASHER	3.000 ea
702623013A	THERMAL BARRIER -- G28 -- BRACKET MTD	1.000 ea
032018008BK	HHCS 5/16-18X1L PLATED	4.000 ea
032018008DK	HHCS 1/2-13X1 PLATED	4.000 ea
032018005DL	1/2-13 X 5/8 SILICON BRONZE HHCS	1.000 ea
035000001A	ALFTG 1/8" 1610-BL	1.000 ea
035000001A	ALFTG 1/8" 1610-BL	1.000 ea
067053014A	GASK 440	1.000 ea
076870000BA	CONDUIT BOX - 440 - 1/2-13 GROUND	1.000 ea
076871000A	+CBOX CVR BLKT - 449	1.000 ea
415039018A	TERBD, 440	1.000 ea
406099000A	PLUG - FAN COVER 320-440	1.000 ea
415000115H	T/LUG #2AWG-4/0AWG	1.000 ea
418150003A	GREASE FITTING CAP	1.000 ea
418150003A	GREASE FITTING CAP	1.000 ea
033775004EA	DRSCR #6-1/4 304 S.S.	2.000 ea
034180054KA	7/8 SQ X 6.75 KEY	1.000 ea

MG1025N19	WILKO 778.50 BLUE GREEN - 55 GAL DRUMS	0.500 ga
004824003CBY	WILKO PAINT 060.02 - ACTIVATOR	0.094 ga
604797056	WOOD BASE 447 60 X 41-1/2 BLT 20 X 18	1.000 ea
MG1500G03-5	LACQUER PRIMER, GRAY	0.094 ga
421948051	LABEL, MYLAR	1.000 ea
LB1449	DIV-2/NEC WARNING LABEL	1.000 ea
412118006A	DRAIN	2.000 ea

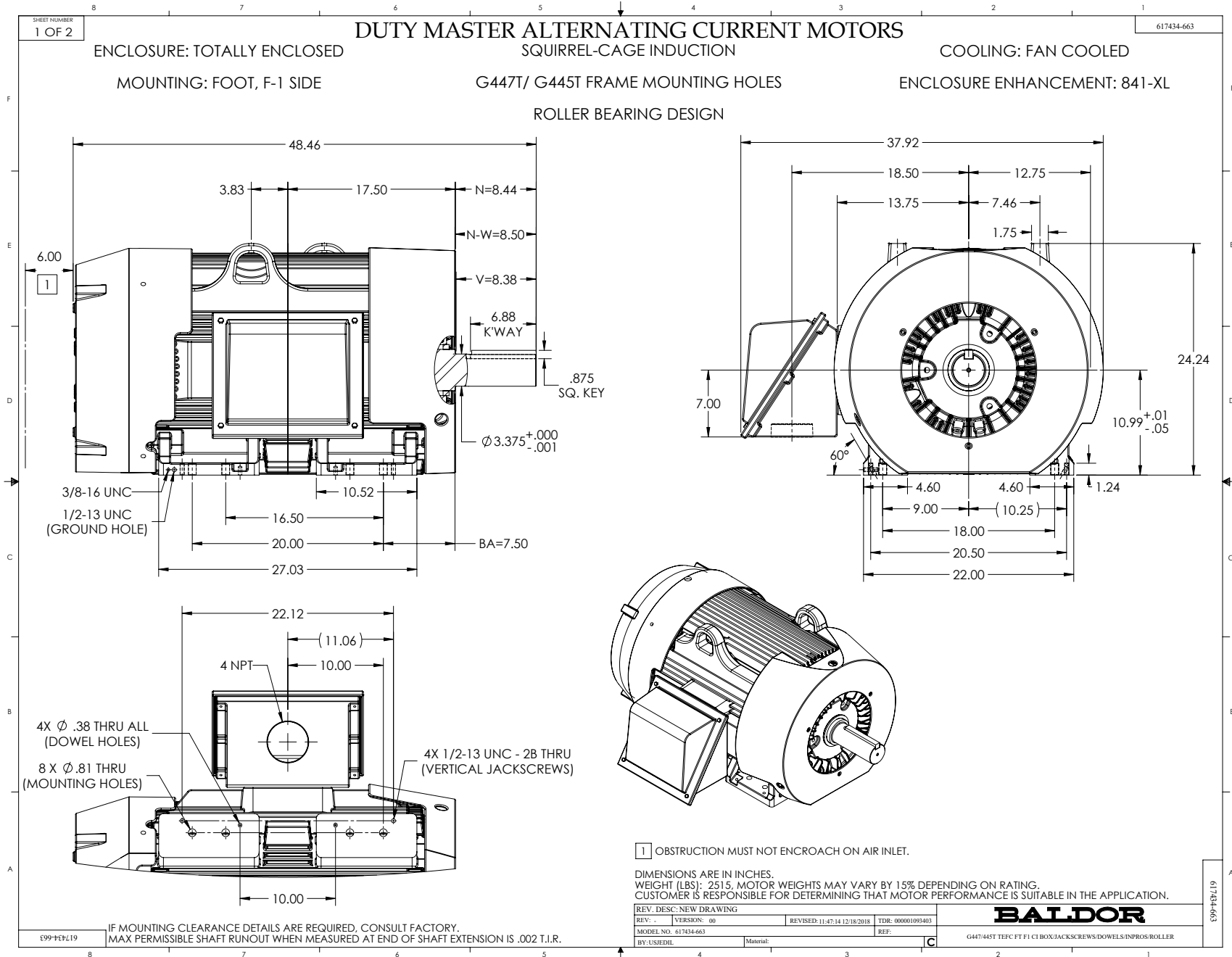

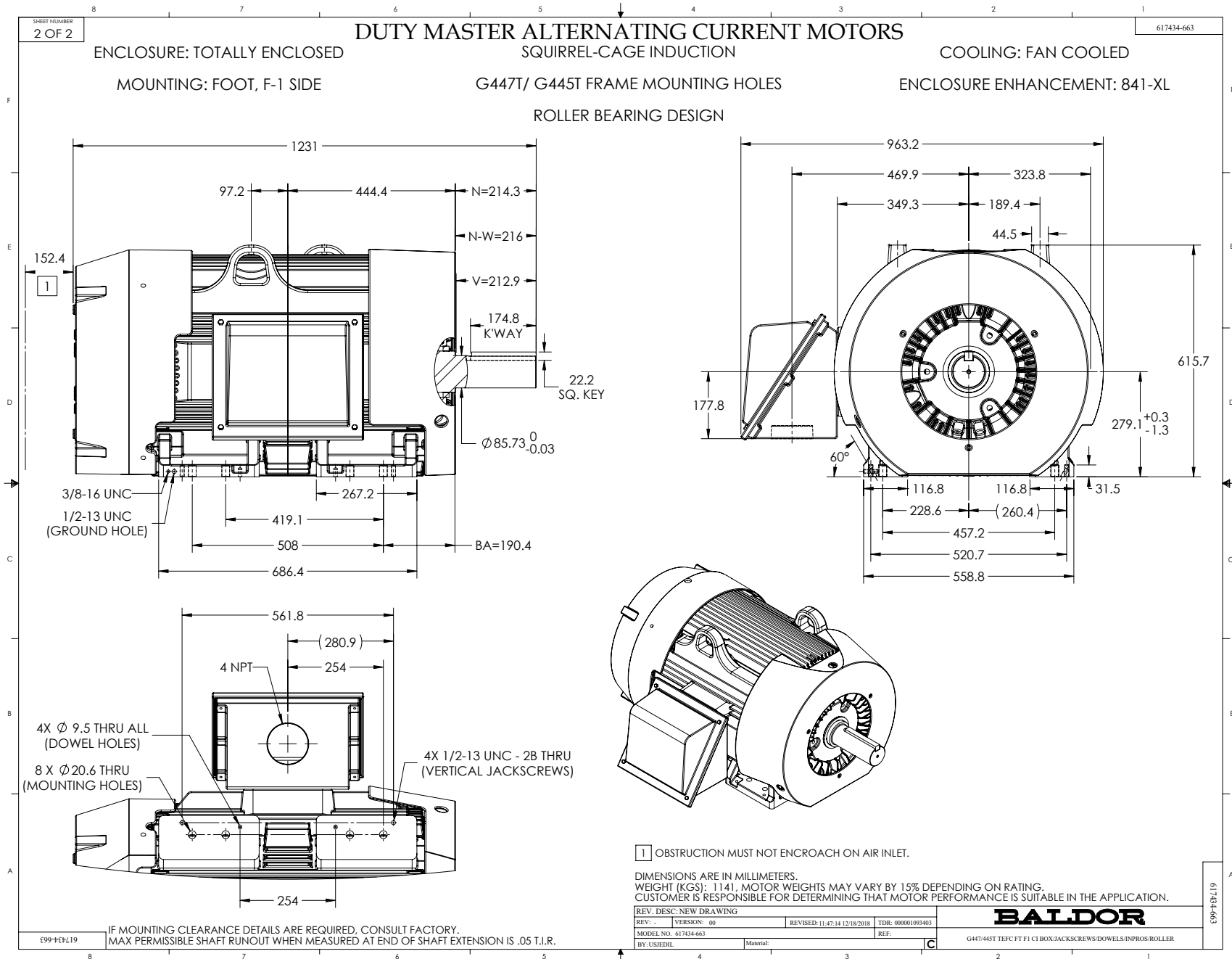

416820-036

A-C MOTOR
CONNECTION DIAGRAM
STANDARD 3 LEAD CONNECTED



(N.P. 1575-BA)

416820-036

REV. DESC: LOADED TO BUS, C/R 335225		
REV. LTR: -	VERSION: 00	TDR: 000000538207
FILE: \MGA\00000\682	REVISED: 11: 54: 06 04/30/2010	
MTL: -	BY: RAGRA	

BALDOR

CONN DIAG - STANDARD 3 LEAD
SH 1 of 1