

BALDOR® • RELIANCE 

Product Information Packet

ECR9074T

7.5HP,1760RPM,3PH,60HZ,213T,0748M,TEFC,F

Part Detail							
Revision:	J	Status:	PRD/A	Change #:		Proprietary:	No
Type:	AC	Elec. Spec:	07WGR837	CD Diagram:	CD0005	Mfg Plant:	
Mech. Spec:	07N167	Layout:	07LYN167	Poles:	04	Created Date:	01-22-2015
Base:	RG	Eff. Date:	07-16-2019	Leads:	9#14		

Specs			
Catalog Number:	ECR9074T	Heater Indicator:	No Heater
Enclosure:	TEFC	Insulation Class:	F
Frame:	213T	Inverter Code:	Inverter Duty
Frame Material:	Iron	KVA Code:	J
Output @ Frequency:	7.500 HP @ 60 HZ	Lifting Lugs:	Standard Lifting Lugs
Synchronous Speed @ Frequency:	1800 RPM @ 60 HZ	Locked Bearing Indicator:	Locked Bearing
Voltage @ Frequency:	460.0 V @ 60 HZ	Motor Lead Quantity/Wire Size:	9 @ 14 AWG
	230.0 V @ 60 HZ	Motor Lead Exit:	Ko Box
XP Class and Group:	None	Motor Lead Termination:	Flying Leads
XP Division:	Not Applicable	Motor Type:	0748M
Agency Approvals:	UR	Mounting Arrangement:	F1
	CSA EEV	Power Factor:	85
	CCSA US	Product Family:	Super-E Chemical Processing
Auxillary Box:	No Auxillary Box	Pulley End Bearing Type:	Ball
Auxillary Box Lead Termination:	None	Pulley Face Code:	Standard
Base Indicator:	Rigid	Pulley Shaft Indicator:	Standard
Bearing Grease Type:	Polyrex EM (-20F +300F)	Rodent Screen:	None
Blower:	None	Shaft Extension Location:	Pulley End

Constant Torque Speed Range:	6	Shaft Ground Indicator:	No Shaft Grounding
Current @ Voltage:	18.600 A @ 230.0 V	Shaft Rotation:	Reversible
	9.300 A @ 460.0 V	Shaft Slinger Indicator:	Shaft Slinger
Design Code:	A	Speed Code:	Single Speed
Drip Cover:	No Drip Cover	Motor Standards:	NEMA
Duty Rating:	CONT	Starting Method:	Direct on line
Electrically Isolated Bearing:	Not Electrically Isolated	Thermal Device - Bearing:	None
Feedback Device:	NO FEEDBACK	Thermal Device - Winding:	None
Front Face Code:	Standard	Vibration Sensor Indicator:	No Vibration Sensor
Front Shaft Indicator:	None	Winding Thermal 1:	None
		Winding Thermal 2:	None

Nameplate NP3294E											
CAT NO	ECR9074T										
SPEC.	07N167R837G1						ENCL	TEFC			
FRAME	213T			HP	7.5						
VOLTS	230/460										
FLA	18.6/9.3				I.P.	55					
RPM	1760			RPM MAX	2700						
HZ	60			PH	3		CLASS	F			
SER.F.	1.25			DES	A		CC	010A			
NEMA-NOM-EFF	91.7										
RATING	40C AMB-CONT										
DE BRG	6309			ODE BRG	6307						
GREASE	POLYREX EM										
INV.TYPE	PWM			C HP FR	60		C HP TO	90			
CT HZ FROM	6			CT HZ TO	60		VT HZ FROM	6		VT HZ TO	60
SER.NO	SFA 22.4/11.2										

Parts List		
Part Number	Description	Quantity
SA293638	SA 07N167R837G1	1.000 EA
RA279731	RA 07N167R837G1	1.000 EA
37FN3002C01	EXFN, PLASTIC, 6.00 OD, 1.155 ID	1.000 EA
HW3201A05	3/8-16 EYEBOLT	1.000 EA
09CB1002A05G	CONDUIT BOX, 1.00 N.P.T. (GRAY)	1.000 EA
RM1017	LEAD SEPERATOR GASKET MODEL 307 1/8" THK	1.000 EA
51XW2520A12	.25-20 X .75, TAPTITE II, HEX WSHR SLTD	2.000 EA
11XW1032G06	10-32 X .38, TAPTITE II, HEX WSHR SLTD U	1.000 EA
HW3001B01	BRASS CUP WASHER, FOR #10 SCREW	1.000 EA
37EP1101A55G	FR EP 07 BRG W/GRS, RELIEF, DRAIN (GRAY)	1.000 EA
HW4500A01	1641B(ALEMITE)400 UNIV, GREASE FITT	1.000 EA
HA4051A00	PLASTIC CAP FOR GREASE FITTING	1.000 EA
HW4500A17	317400 ALEMITE GREASE RELIEF	1.000 EA
HA4054	SHORT T-DRAIN FITTING, .125" N.P.T.	1.000 EA
HW5100A08	W3118-035 WVY WSHR (WB)	1.000 EA
37EP1111A04G	PULLEY ENCL 309 BRG W/GRSR,RELIF & LOCKED	1.000 EA
HW4500A01	1641B(ALEMITE)400 UNIV, GREASE FITT	1.000 EA
HA4051A00	PLASTIC CAP FOR GREASE FITTING	1.000 EA
HW4500A17	317400 ALEMITE GREASE RELIEF	1.000 EA
HA4054	SHORT T-DRAIN FITTING, .125" N.P.T.	1.000 EA
10XN2520A26	1/4-20X 1 5/8 HEX HD	4.000 EA
XY3118A12	5/16-18 HEX NUT DIRECTIONAL SERRATION	4.000 EA
51XB1214A20	12-14X1.25 HXWSSLD SERTYB	1.000 EA
07FH1001A01G	SPL FAN HOUSING, 307, W/GREASER, GRAY EP	1.000 EA

Parts List (continued)		
Part Number	Description	Quantity
10XN2520A28	1/4-20X 1 3/4 HEX HD	3.000 EA
WD4100A02	DP-1000 HEYCO PLUG OR 62MP1000 MICRO PL	1.000 EA
12CB1503G	CONDUIT BOX CAST. (GRAY)	1.000 EA
09GS1013A01	09 GS FOR 09CB3501 LID - BLACK NEOPRENE	1.000 EA
10XN2520A12	1/4-20 X 3/4 HEX HEAD CAP	2.000 EA
HW1001A25	LOCKWASHER 1/4, ZINC PLT .493 OD, .255 I	2.000 EA
HW4600C51	31X39X7.5MM FACE SEAL FOR 1.375 DIA. SH	1.000 EA
HW4600B44	V-RING SLINGER 1.500 X 1.810 X .28 VITON	1.000 EA
HW2501F21	KEY, 5/16 SQ X 2.375	1.000 EA
HA7000A02	KEY RETAINER RING, 1 1/8 DIA, 1 3/8 DIA	1.000 EA
MJ5001A27	32220KN GRAY SEALER *MIN BUY 4 QTS=1GAL	0.001 QT
85XU0407S04	4X1/4 U DRIVE PIN STAINLESS	2.000 EA
LB1115N	LABEL,LIFTING DEVICE (ON ROLLS)	1.000 EA
MJ1000A02	GREASE, MOBIL POLYREX EM - 124047	0.050 LB
HA3104A32	THRUBOLT- 5/16-18 X12.750	4.000 EA
MG1025G96	WILKOFASST SG, 779.7048, MOUSE GRAY #7048	0.036 GA
LC0005E01	CONN.DIA./WARNING LABEL (LC0005/LB1119N)	1.000 EA
NP3294E	SS CRUSHER DUTY INV UL CSA-C US EEV	1.000 EA
07PA1011	PKG GRP, 07 CAST IRON PK1181	1.000 EA
MN416A01	TAG-INSTAL-MAINT no wire (2100/bx) 4/22	1.000 EA

AC Induction Motor Performance Data

Record # 49026

Typical performance - not guaranteed values

Winding: 07WGR837-R001		Type: 0748M		Enclosure: TEFC	
Nameplate Data			460 V, 60 Hz: High Voltage Connection		
Rated Output (HP)	7.5	Full Load Torque	22.1 LB-FT		
Volts	230/460	Start Configuration	direct on line		
Full Load Amps	18.6/9.3	Breakdown Torque	77.3 LB-FT		
R.P.M.	1760	Pull-up Torque	39.4 LB-FT		
Hz	60 Phase	Locked-rotor Torque	48.4 LB-FT		
NEMA Design Code	A KVA Code	Starting Current	74 A		
Service Factor (S.F.)	1.25	No-load Current	4.04 A		
NEMA Nom. Eff.	91.7 Power Factor	Line-line Res. @ 25°C	1.26 Ω		
Rating - Duty	40C AMB-CONT	Temp. Rise @ Rated Load	38°C		
S.F. Amps	22.4/11.2	Temp. Rise @ S.F. Load	52°C		
		Locked-rotor Power Factor	37.9		
		Rotor inertia	1.18 LB-FT ²		

Load Characteristics 460 V, 60 Hz, 7.5 HP

% of Rated Load	25	50	75	100	125	150	S.F.
Power Factor	44	66	77	81	84	85	84
Efficiency	87.5	91.9	92.5	92.5	91.7	90.8	91.8
Speed	1792	1786	1779	1772	1764	1755	1765
Line amperes	4.54	5.79	7.38	9.28	11.4	13.6	11.4

Performance Graph at 460V, 60Hz, 7.5HP Typical performance - Not guaranteed values

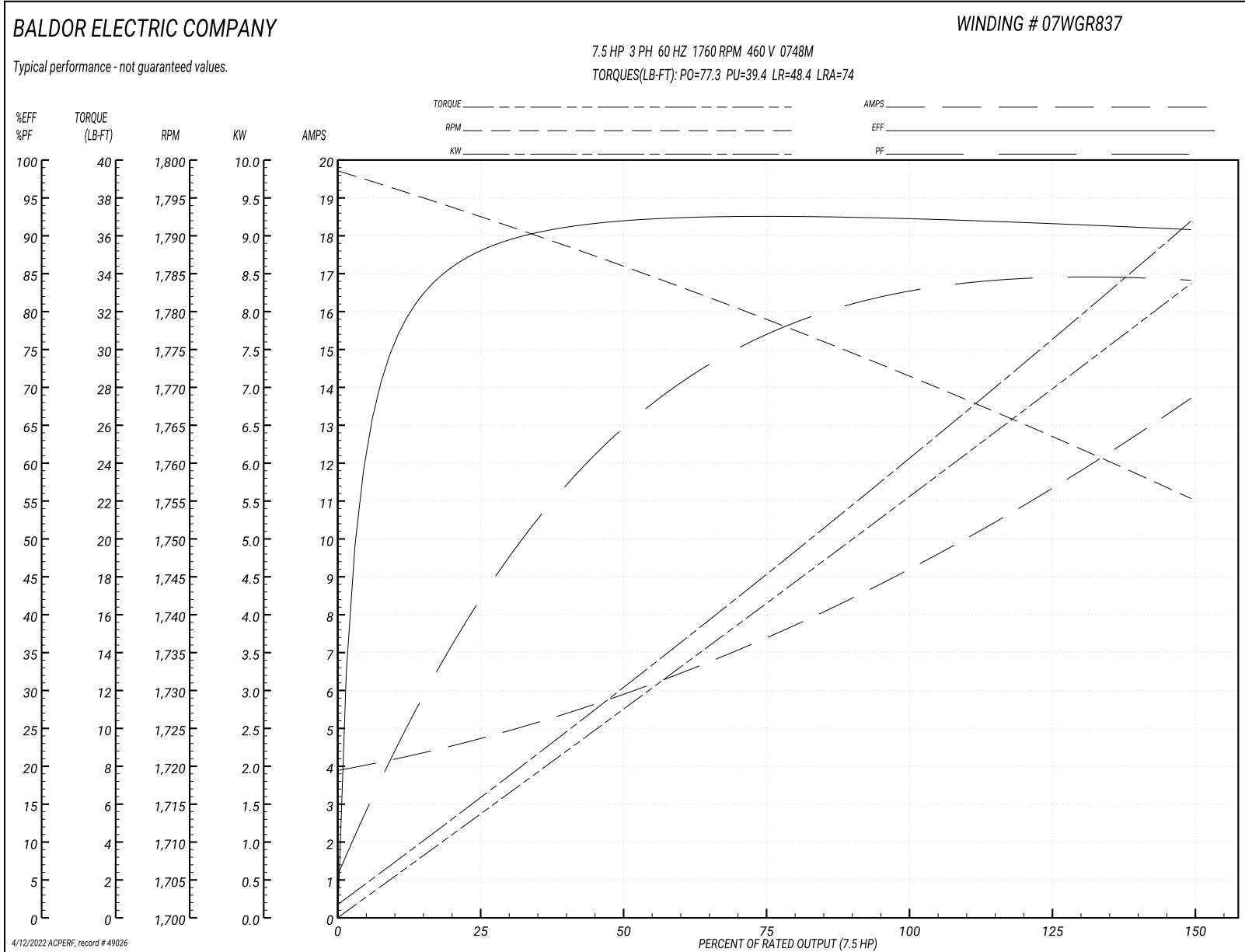

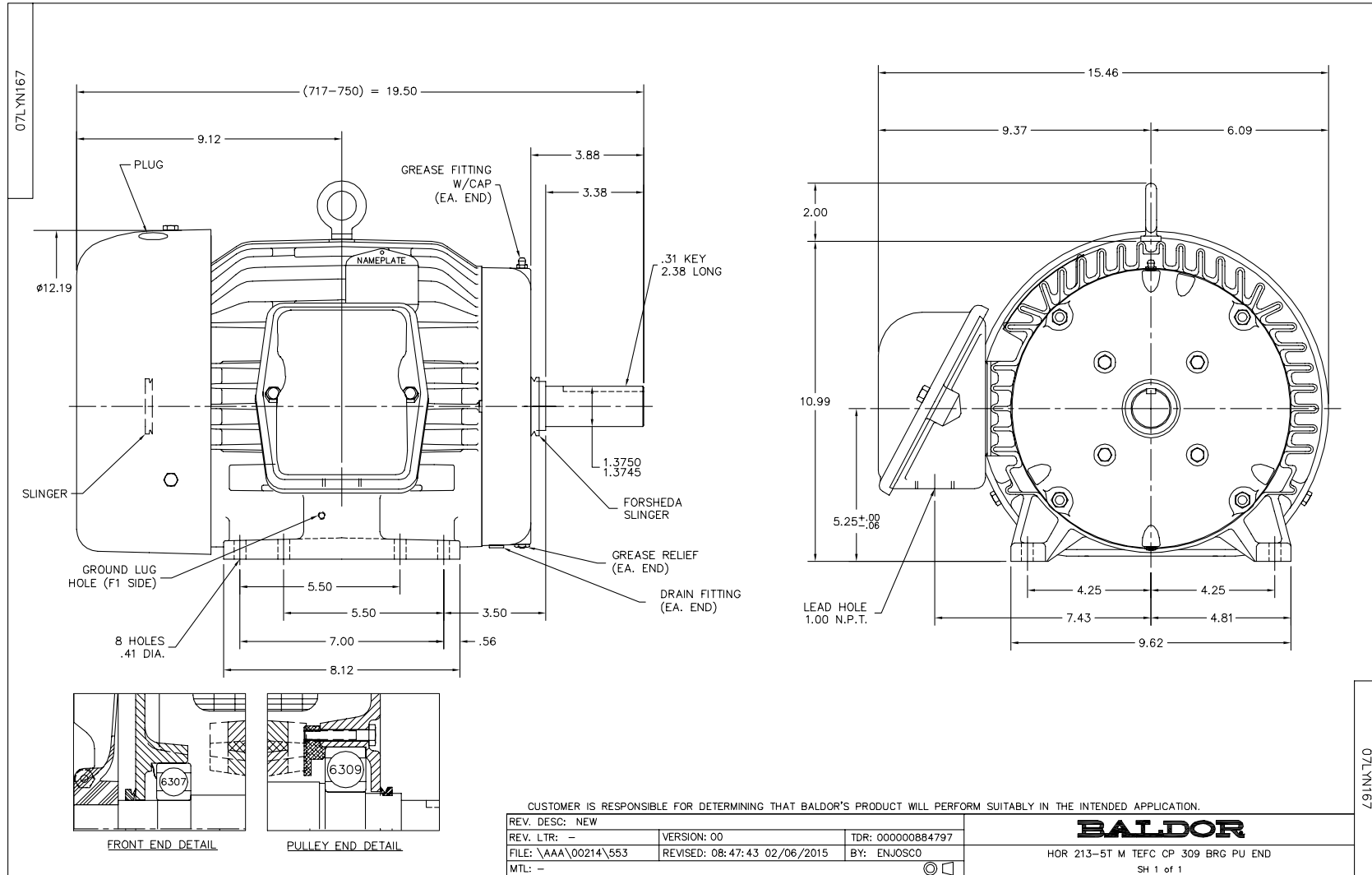

CD0005

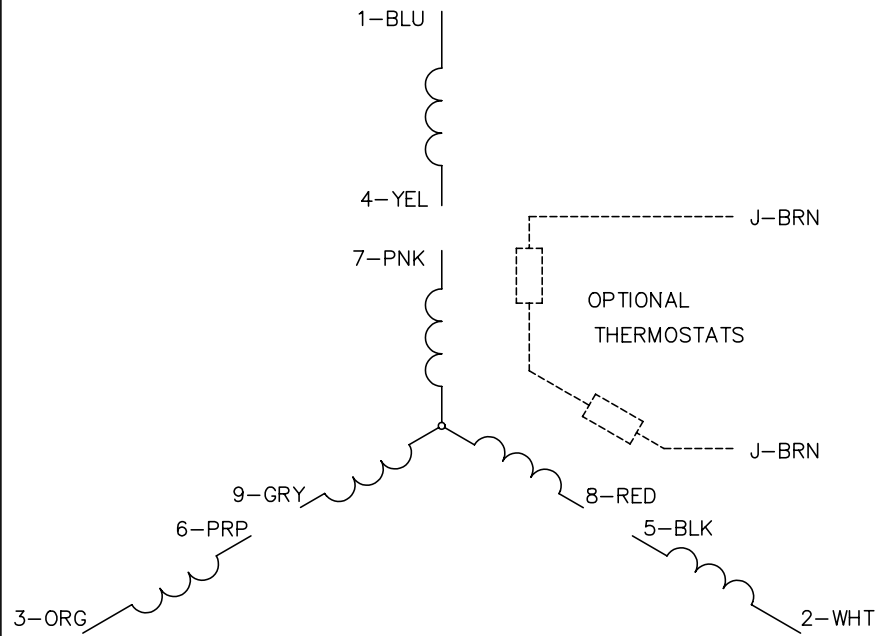

LOW VOLTAGE
(2Y)

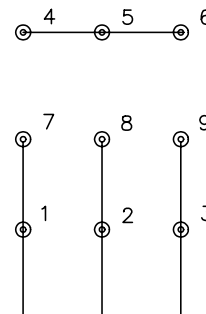

LINE

HIGH VOLTAGE
(1Y)



LINE

NOTES:

1. INTERCHANGE ANY TWO LINE LEADS TO REVERSE ROTATION.
2. OPTIONAL THERMOSTATS ARE PROVIDED WHEN SPECIFIED.
3. ACTUAL NUMBER OF INTERNAL PARALLEL CIRCUITS MAY BE A MULTIPLE OF THOSE SHOWN ABOVE.
4. LEAD COLORS ARE OPTIONAL. LEADS MUST ALWAYS BE NUMBERED AS SHOWN.

REV. DESC: REVISE TO SHOW OPTIONAL COLORS			
REV. LTR: E	BY: JLP	REVISED: 01/19/99 10:15	TDR: 0171435
90000		FILE: AAA00005140	MDL: -
		MTL: -	

BALDOR ELECTRIC Co.

3PH, DV, 9 LEADS

CD0005