

**BALDOR • RELIANCE**

---

# Customer information packet

## ECR91004TR-4

100HP, 1785RPM, 3PH, 60HZ, 405T, A40076M, TEFC

Class - None

Division - Not Applicable

## Specifications

Enclosure	TEFC
Frame	405T
Frame Material	Iron
Frequency	60.00 Hz
Motor Letter Type	Three Phase
Output @ Frequency	100.000 HP @ 60 HZ
Phase	3
Synchronous Speed @ Frequency	1800 RPM @ 60 HZ
Voltage @ Frequency	460.0 V @ 60 HZ
XP Class and Group	None
XP Division	Not Applicable
Agency Approvals	CSA EEV
Ambient Temperature	40 °C
Auxillary Box	No Auxillary Box
Base Indicator	Rigid
Bearing Grease Type	Mobil SHC 220 (Athens Only)
Constant Torque Speed Range	6-60
Current @ Voltage	115.000 A @ 460.0 V
Design Code	A
Drip Cover	No Drip Cover
Duty Rating	CONT
Efficiency @ 100% Load	95.4 %
Feedback Device	NO FEEDBACK
Heater Indicator	No Heater
High Voltage Full Load Amps	115.0 a
Insulation Class	F
Inverter Code	Inverter Ready
KVA Code	H
Lifting Lugs	Standard Lifting Lugs
Max Speed	3600 rpm
Motor Lead Quantity/Wire Size	3 @ 1 AWG
Motor Standards	NEMA

## Part detail

Revision	K
Type	AC
Mech. spec.	
Base	
Status	PRD/A
Elec. spec.	A40WG0454
Layout	617429-501
Eff. date	03-12-2020
CD Diagram	416820-036
Poles	04
Leads	3#1
Proprietary	False
Created date	01-31-2015

<b>Motor Type</b>	A40076M
<b>Mounting Arrangement</b>	F1
<b>Number of Poles</b>	4
<b>Overall Length</b>	38.04 IN
<b>Power Factor</b>	85
<b>Product Family</b>	Crusher / Chipper
<b>Pulley End Bearing Type</b>	Roller
<b>Pulley Face Code</b>	Standard
<b>Service Factor</b>	1.25
<b>Shaft Ground Indicator</b>	No Shaft Grounding
<b>Shaft Rotation</b>	Reversible
<b>Shaft Slinger Indicator</b>	No Slinger
<b>Speed</b>	1785 rpm
<b>Speed Code</b>	Single Speed
<b>Starting Method</b>	Direct on line
<b>Thermal Device - Bearing</b>	None
<b>Thermal Device - Winding</b>	None

**Nameplate**

**000613007PV**

<b>CAT NO</b>	ECR91004TR-4		<b>SPEC NO.</b>	P40G1705					
<b>HP</b>	100	<b>AMPS</b>	115	<b>VOLTS</b>	460	<b>DESIGN</b>	A		
<b>RPM</b>	1785	<b>RPM MAX</b>	3600	<b>HZ</b>	60	<b>AMB</b>	40	<b>SF</b>	1.25
<b>D.E. BRG.DATA</b>	NU316	<b>O.D.E. BRG.DATA</b>	6316	<b>PH</b>	3	<b>DUTY</b>	CONT	<b>INSUL.CLASS</b>	F
<b>FRAME</b>	405T	<b>I.P.</b>	55	<b>TYPE</b>	P	<b>ENCL</b>	TEFC	<b>CODE</b>	H
<b>POWER FACTOR</b>	85	<b>3/4 LOAD EFF.</b>	93.3	<b>NEMA NOM EFFICIENCY</b>	95.4				
<b>CHP HZ</b>	60-90	<b>CT HZ</b>	6-60	<b>VT HZ</b>	6-60				
<b>SER.NO.</b>			<b>MOTOR WEIGHT</b>						
		1.25SF AMPS= 132							

---

**NP2496L**

---

MOBIL SHC -220 GREASE

---

## Parts list

Part number	Description	Quantity
SA293583	SA P40G1705	1.000 ea
RA279676	RA P40G1705	1.000 ea
000613007PV	SS NP, CRUSHER DUTY, EMBOSSSED,MAIN MOTOR	1.000 ea
000692000RT	N/P	1.000 ea
000692000FF	N/P	1.000 ea
000692000VD	LABEL WARNING	1.000 ea
NP2496L	MOTOR LUBE NAMEPLATE	1.000 ea
004824015AP	GREASE MOBILITH SHC 220	0.884 lb
032018008CK	HHCS 3/8-16X1L PLATED	4.000 ea
032018020EK	HHCS 5/8-11X2-1/2 PLTD.	4.000 ea
032018024CK	HHCS 3/8-16X3 PLTD.	3.000 ea
034692005AA	P PLUG 3/4"BLK.	1.000 ea
034000014AB	WSH ID.406 OD.812 TH.065	4.000 ea
034180012DA	KEY 1X4X1/4X1-1/2 L	1.000 ea
034530052AB	P/NIP 1/8X6-1/2 Zinc	1.000 ea
034530056BB	P/NIP 1/4X7 SCHED 40	1.000 ea
034631002AB	BUSH 1/4 TO 1/8 PLTD.	1.000 ea
047174001AS	EXT SNAP RING(400)	1.000 ea
078548001R	FAN KB 234/150 (84) 400	1.000 ea
083198101A	G400 STD FAN COVER MACHINING	1.000 ea
089412501A	BRKT FTMT G400 FIN MACH 6316 89412500WCA	1.000 ea
415045002B	SLGR	1.000 ea
415072001B	CLAMP	1.000 ea
415096002A	CPLG 1/8 HEX TYPE	1.000 ea
032018020EK	HHCS 5/8-11X2-1/2 PLTD.	4.000 ea
032018024CK	HHCS 3/8-16X3 PLTD.	3.000 ea
034530040AB	P/NIP 1/8X5 GALV.	1.000 ea
034530040BB	P/NIP 1/4X5	1.000 ea
034631002AB	BUSH 1/4 TO 1/8 PLTD.	1.000 ea
089412501A	BRKT FTMT G400 FIN MACH 6316 89412500WCA	1.000 ea
415096002A	CPLG 1/8 HEX TYPE	1.000 ea

415045002B	SLGR	1.000 ea
032018010CK	HHCS 3/8-16X1-1/4 PLTD. 032018010CR	4.000 ea
033512008LB	HHTTS 1/4-20X1 PLATED	4.000 ea
034000014AB	WSH ID.406 OD.812 TH.065	4.000 ea
035000001A	ALFTG 1/8" 1610-BL	1.000 ea
035000001A	ALFTG 1/8" 1610-BL	1.000 ea
065776000C	GASKET,MAIN CBOX, 320-400	1.000 ea
067053000B	GASK 320-400	1.000 ea
076708000BB	CONDUIT BOX-360	1.000 ea
076709000A	C/B Cover - 360	1.000 ea
406099000A	PLUG - FAN COVER 320-440	1.000 ea
415000115H	T/LUG #2AWG-4/0AWG	1.000 ea
418150003A	GREASE FITTING CAP	1.000 ea
418150003A	GREASE FITTING CAP	1.000 ea
033775004EA	DRSCR #6-1/4 304 S.S.	4.000 ea
034180044JA	KEY 3/4X3/4X5-1/2 L	1.000 ea
MG1025G96	WILKOFAST SG, 779.7048, MOUSE GRAY #7048	0.375 ga
421948051	LABEL, MYLAR	1.000 ea
000613006PU	N/P (RELEASE QTY 10,000) UL CSA LABEL	1.000 ea
034001016AB	WSHR .562ID 1.375OD .109	1.000 ea
034001014AB	FLAT WASHER 3/8"PLATED	1.000 ea
035000001G	GREASE RELIEF FITTING, ALEMITE 317400	1.000 ea
035000001G	GREASE RELIEF FITTING, ALEMITE 317400	1.000 ea
415070001A	RUBBER MOUNT 3X3X1 THICK	1.000 ea
032018024CK	HHCS 3/8-16X3 PLTD.	1.000 ea
604797013R	447 FR. ROLLER BEARING MOTOR SHAFT	1.000 ea
604799003C	PLASTIC BAG 42X32X46	1.000 ea
033300014AC	HEX NUT, SHIPPING - 400	2.000 ea
034001016AB	WSHR .562ID 1.375OD .109	2.000 ea
034001014AB	FLAT WASHER 3/8"PLATED	2.000 ea
032510024D	CARRIAGE BOLT - 444	2.000 ea
604797045	STD. 400 FRAME SKID	1.000 ea
032018005DL	1/2-13 X 5/8 SILICON BRONZE HHCS	1.000 ea
412118006A	DRAIN	2.000 ea

617429-501

# DUTY MASTER ALTERNATING CURRENT MOTORS

## SQUIRREL-CAGE INDUCTION

ENCLOSURE: TOTALLY ENCLOSED

FRAME G405T ABOVE NEMA RATINGS

COOLING: FAN COOLED

MOUNTING: FOOT

INCLUDES 404T FRAME MOUNTING HOLES

XT/ECP SEVERE DUTY ENCLOSURE

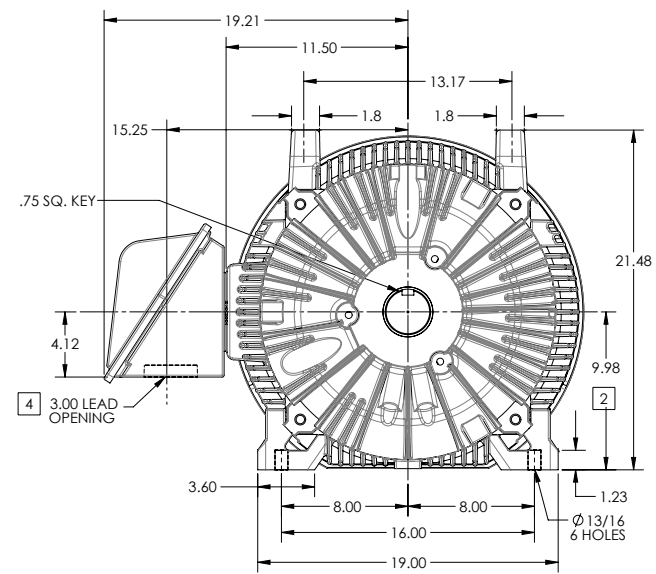
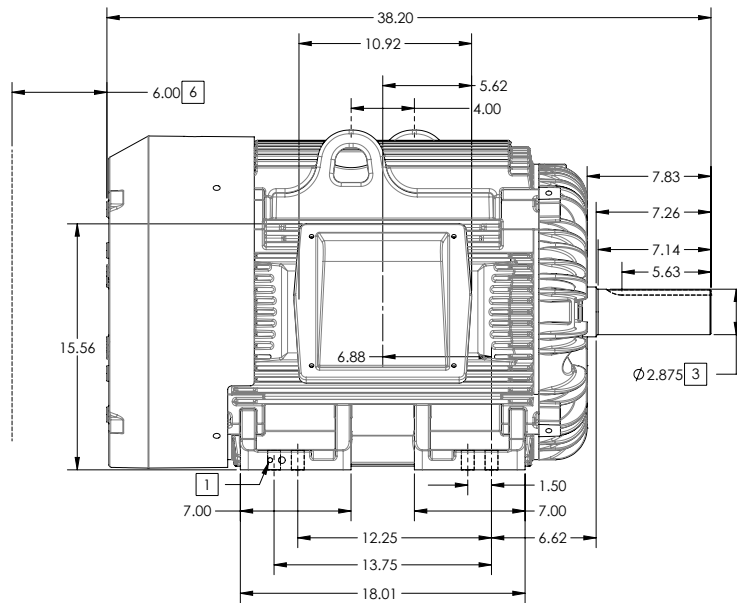

1. GROUND HOLES QTY 1 1/2-13 TAP; QTY 1 3/8-16 TAP
2. VARIES +.00,-.06
3. VARIES +.00,-.001
4. ON STANDARD MOTORS THIS IS CONDUIT SIZE. ON XT AND CORROSION PROOF MOTOR THIS IS PIPE TAP.
5. MOTOR WEIGHTS MAY VARY BY 15% DEPENDING ON RATING.
6. OBSTRUCTION MUST NOT ENCROACH ON AIR INLET

**[5] WEIGHT (LBS): 1370**

CONDUIT BOX LOCATED ON OPPOSITE SIDE WHEN F-2. IF MOUNTING CLEARANCE DETAILS ARE REQUIRED, CONSULT FACTORY. MAXIMUM PERMISSIBLE SHAFT RUNOUT WHEN MEASURED AT END OF STANDARD SHAFT EXTENSION IS .003" T.I.R. TO 5 INCH DIA.

DIMENSIONS ARE IN INCHES; SEE SHEET 2 FOR DIMENSIONS IN MILLIMETERS

CUSTOMER IS RESPONSIBLE FOR DETERMINING THAT MOTOR PERFORMANCE IS SUITABLE IN THE APPLICATION.

SHEET NUMBER  
**1 OF 2**

105-627219

REV. DESC: CHANGE BA FROM 6.76 TO 6.62			
REV: B	VERSION: 02	REVISED: 01-11-16 04/14/2014	TDR: 00000848770
MODEL NO. 617429-501		REF:	
BY: MGHMMZ2		Material:	

**BALDOR**

G405T/404T STD - FOOTED - XT/ECP SEVERE DUTY ENCLOSURE

617429-501



# DUTY MASTER ALTERNATING CURRENT MOTORS

## SQUIRREL-CAGE INDUCTION

ENCLOSURE: TOTALLY ENCLOSED

FRAME G405T ABOVE NEMA RATINGS

COOLING: FAN COOLED

MOUNTING: FOOT

INCLUDES 404T FRAME MOUNTING HOLES

XT/ECP SEVERE DUTY ENCLOSURE

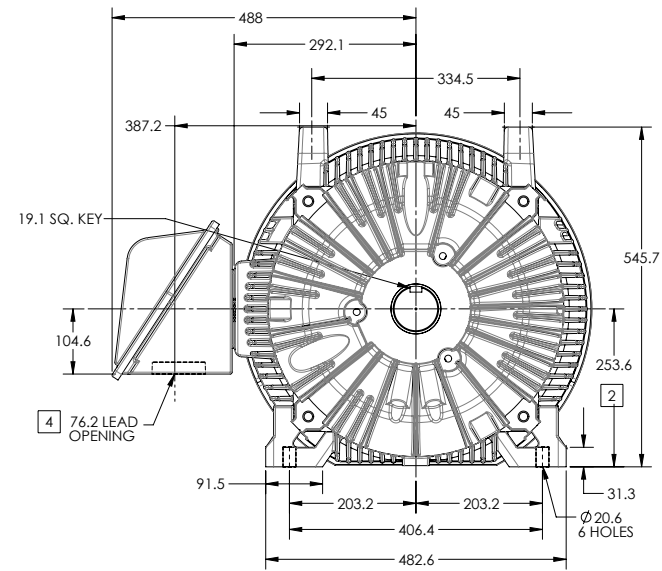
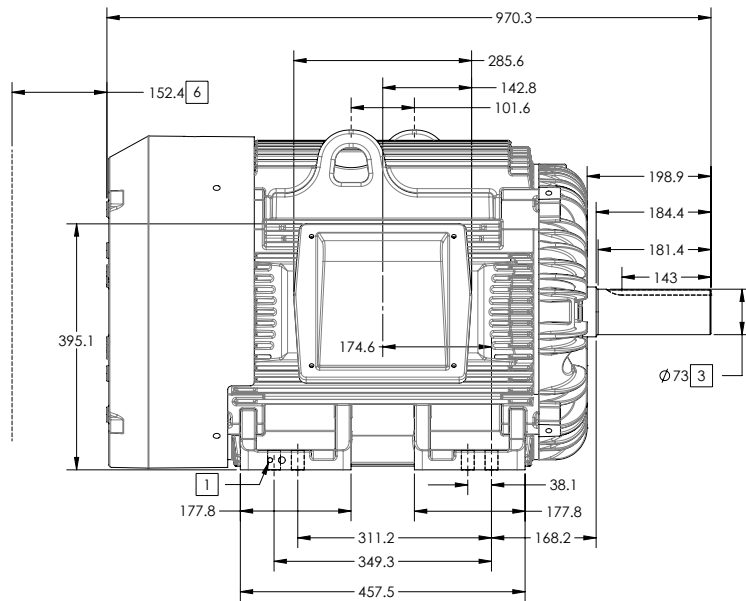

1. GROUND HOLES QTY 1 1/2-13 TAP; QTY 1 3/8-16 TAP
2. VARIES +0,-1.5
3. VARIES +00,-.03
4. ON STANDARD MOTORS THIS IS CONDUIT SIZE. ON XT AND CORROSION PROOF MOTOR THIS IS PIPE TAP.
5. MOTOR WEIGHTS MAY VARY BY 15% DEPENDING ON RATING.
6. OBSTRUCTION MUST NOT ENCROACH ON AIR INLET

**[5] WEIGHT (KGS): 630**

CONDUIT BOX LOCATED ON OPPOSITE SIDE WHEN F-2. IF MOUNTING CLEARANCE DETAILS ARE REQUIRED, CONSULT FACTORY. MAXIMUM PERMISSIBLE SHAFT RUNOUT WHEN MEASURED AT END OF STANDARD SHAFT EXTENSION IS .08 MM T.I.R. TO 127 MM DIA.

DIMENSIONS ARE IN MILLIMETERS; SEE SHEET 1 FOR DIMENSIONS IN INCHES

CUSTOMER IS RESPONSIBLE FOR DETERMINING THAT MOTOR PERFORMANCE IS SUITABLE IN THE APPLICATION.

SHEET NUMBER  
**2 OF 2**

105-627219

REV. DESC: CHANGE BA FROM 6.76 TO 6.62	TDR: 00000848770
REV: B VERSION: 02	REVISED: 01-11-16 04/14/2014
MODEL NO. 617429-501	REF:
BY: MGHMMZ2	Material:

**BALDOR**

G405T/404T STD - FOOTED - XT/ECP SEVERE DUTY ENCLOSURE

416820-036

A-C MOTOR  
CONNECTION DIAGRAM  
STANDARD 3 LEAD CONNECTED



(N.P. 1575-BA)

416820-036

REV. DESC: LOADED TO BUS, C/R 335225		
REV. LTR: -	VERSION: 00	TDR: 000000538207
FILE: \MGA\00000\682	REVISED: 11:54:06 04/30/2010	
MTL: -	BY: RAGRA	

**BALDOR**

CONN DIAG - STANDARD 3 LEAD  
SH 1 of 1