

BALDOR • RELIANCE

Customer information packet

ECR91006TR-4

100HP, 1190RPM, 3PH, 60HZ, 444T, A44084M, TEFC

Class - None

Division - Not Applicable

Specifications

Enclosure	TEFC
Frame	444T
Frame Material	Iron
Frequency	60.00 Hz
Motor Letter Type	Three Phase
Output @ Frequency	100.000 HP @ 60 HZ
Phase	3
Synchronous Speed @ Frequency	1200 RPM @ 60 HZ
Voltage @ Frequency	460.0 V @ 60 HZ
XP Class and Group	None
XP Division	Not Applicable
Agency Approvals	CSA EEV
Ambient Temperature	40 °C
Auxillary Box	No Auxillary Box
Base Indicator	Rigid
Bearing Grease Type	Mobil SHC 220 (Athens Only)
Constant Torque Speed Range	6-60
Current @ Voltage	119.000 A @ 460.0 V
Design Code	A
Drip Cover	No Drip Cover
Duty Rating	CONT
Efficiency @ 100% Load	95.0 %
Feedback Device	NO FEEDBACK
Heater Indicator	No Heater
High Voltage Full Load Amps	119.0 a
Insulation Class	F
Inverter Code	Inverter Ready
KVA Code	H
Lifting Lugs	No Lifting Lugs
Max Speed	3000 rpm
Motor Lead Quantity/Wire Size	3 @ 1 AWG
Motor Standards	NEMA

Part detail

Revision	H
Type	AC
Mech. spec.	
Base	
Status	PRD/A
Elec. spec.	A44WG1491
Layout	617427-315
Eff. date	10-29-2020
CD Diagram	416820-036
Poles	06
Leads	3#1
Proprietary	False
Created date	01-30-2015

Motor Type	A44084M
Mounting Arrangement	F1
Number of Poles	6
Overall Length	44.75 IN
Power Factor	83
Product Family	Crusher / Chipper
Pulley End Bearing Type	Roller
Pulley Face Code	Standard
Service Factor	1.25
Shaft Ground Indicator	No Shaft Grounding
Shaft Rotation	Reversible
Shaft Slinger Indicator	Shaft Slinger
Speed	1190 rpm
Speed Code	Single Speed
Starting Method	Direct on line
Thermal Device - Bearing	None
Thermal Device - Winding	None

Nameplate

000613007PV

CAT NO	ECR91006TR-4	SPEC NO.	P44G1805							
HP	100	AMPS	119	VOLTS	460	DESIGN	A			
RPM	1190	RPM MAX	3000	HZ	60	AMB	40	SF	1.25	
D.E. BRG.DATA	NU222	O.D.E. BRG.DATA	6318		PH	3	DUTY	CONT	INSUL.CLASS	F
FRAME	444T	I.P.	55	TYPE	P	ENCL	TEFC	CODE	H	
POWER FACTOR	83	3/4 LOAD EFF.	95.0		NEMA NOM EFFICIENCY	95				
CHP HZ	60-90	CT HZ	6-60	VT HZ	6-60					
SER.NO.	MOTOR WEIGHT									
1.25SF AMPS= 146										

NP2496L

MOBIL SHC -220 GREASE

Parts list

Part number	Description	Quantity
SA293582	SA P44G1805	1.000 ea
RA279675	RA P44G1805	1.000 ea
000613007PV	SS NP, CRUSHER DUTY, EMBOSSSED,MAIN MOTOR	1.000 ea
000692000FF	N/P	1.000 ea
000692000RT	N/P	1.000 ea
000692000VD	LABEL WARNING	1.000 ea
NP2496L	MOTOR LUBE NAMEPLATE	1.000 ea
032018008CK	HHCS 3/8-16X1L PLATED	4.000 ea
032018020FK	HHCS 3/4-10X2-1/2 PLTD.	4.000 ea
032018030DK	HHCS 1/2-13X3-3/4 PLTD.	3.000 ea
032620016LA	SOCKET SET SCREW-449	3.000 ea
034017014AB	LCKW 3/8 STD. PLATED	4.000 ea
034180014DA	KEY 1/4X1/4X1-3/4 L	1.000 ea
034530064AB	P/NIP 1/8 X 8" L Pipe Nipple	1.000 ea
034530064BB	P/NIP 1/4X8 PLATED	1.000 ea
034631002AB	BUSH 1/4 TO 1/8 PLTD.	1.000 ea
035000001G	GREASE RELIEF FITTING, ALEMITE 317400	1.000 ea
034690005AB	PPLG 3/4 PLATED	2.000 ea
078550001H	FAN KB 120/60 360	1.000 ea
083199082A	G28 FAN COVER MACHINING SHORT VERSION	1.000 ea
089490099A	G28 BRKT 089490098WCA KB	1.000 ea
415045002A	SLGR	1.000 ea
415072001B	CLAMP	1.000 ea
415096002A	CPLG 1/8 HEX TYPE	1.000 ea
418151014G	RETAIN RING	1.000 ea
032018004BK	HHCS 5/16-18X1/2 PLATED	3.000 ea
032018020FK	HHCS 3/4-10X2-1/2 PLTD.	4.000 ea
032018030DK	HHCS 1/2-13X3-3/4 PLTD.	3.000 ea
034017013AB	LCKW 5/16 STD. PLATED	3.000 ea
034530036AB	P/NIP 1/8 X4-1/2 Yellow Zinc46114-BM	1.000 ea
034530036BB	P/NIP 1/4X4-1/2 GALV.	1.000 ea

034631002AB	BUSH 1/4 TO 1/8 PLTD.	1.000 ea
035000001G	GREASE RELIEF FITTING, ALEMITE 317400	1.000 ea
089490101A	G28 BRKT 089490100WCA	1.000 ea
415045002D	SLGR - 440 V1T45B	1.000 ea
415096002A	CPLG 1/8 HEX TYPE	1.000 ea
415915007G	GASK, LAC	1.000 ft
418151014H	RETAIN RING	1.000 ea
702623013A	THERMAL BARRIER -- G28 -- BRACKET MTD	1.000 ea
032018008BK	HHCS 5/16-18X1L PLATED	4.000 ea
032018008DK	HHCS 1/2-13X1 PLATED	4.000 ea
033512006LB	HHTTS 1/4-20X3/4 PLTD.	1.000 ea
035000001A	ALFTG 1/8" 1610-BL	1.000 ea
035000001A	ALFTG 1/8" 1610-BL	1.000 ea
067053001C	GASK 440	1.000 ea
076863000C	+CBCST BLKT - 440	1.000 ea
076864000A	CBCST BLKT - 440	1.000 ea
406056007A	GASKET, 440	1.000 ea
406099000A	PLUG - FAN COVER 320-440	1.000 ea
415000103D	T/LUG #4AWG-1/0AWG W/HOLE FOR .250 BOLT	1.000 ea
418150003A	GREASE FITTING CAP	1.000 ea
418150003A	GREASE FITTING CAP	1.000 ea
033775004EA	DRSCR #6-1/4 304 S.S.	2.000 ea
034180054KA	7/8 SQ X 6.75 KEY	1.000 ea
MG1025G96	WILKOFASST SG, 779.7048, MOUSE GRAY #7048	0.440 ga
421948051	LABEL, MYLAR	1.000 ea
004824015AP	GREASE MOBILITH SHC 220	1.160 lb
000613006PU	N/P (RELEASE QTY 10,000) UL CSA LABEL	1.000 ea
034001016AB	WSHR .562ID 1.375OD .109	1.000 ea
034001014AB	FLAT WASHER 3/8"PLATED	1.000 ea
032018028CK	HHCS 3/8-16X3-1/2 PLTD.	1.000 ea
604797001R	440 FR. ROLLER BEARING MOTOR SHAFT	1.000 ea
604799003C	PLASTIC BAG 42X32X46	1.000 ea
033300014AC	HEX NUT, SHIPPING - 400	2.000 ea
034001016AB	WSHR .562ID 1.375OD .109	2.000 ea

034001014AB	FLAT WASHER 3/8"PLATED	2.000 ea
032510024D	CARRIAGE BOLT - 444	2.000 ea
604797045	STD. 400 FRAME SKID	1.000 ea
412118006A	DRAIN	2.000 ea

DUTY MASTER ALTERNATING CURRENT MOTORS
SQUIRREL-CAGE INDUCTION

617427-315

ENCLOSURE: TOTALLY ENCLOSED

MOUNTING: FOOT

COOLING: FAN COOLED

FRAMES G445T/444T

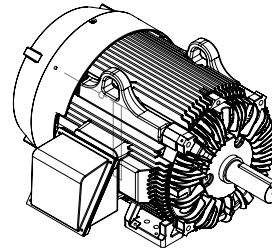
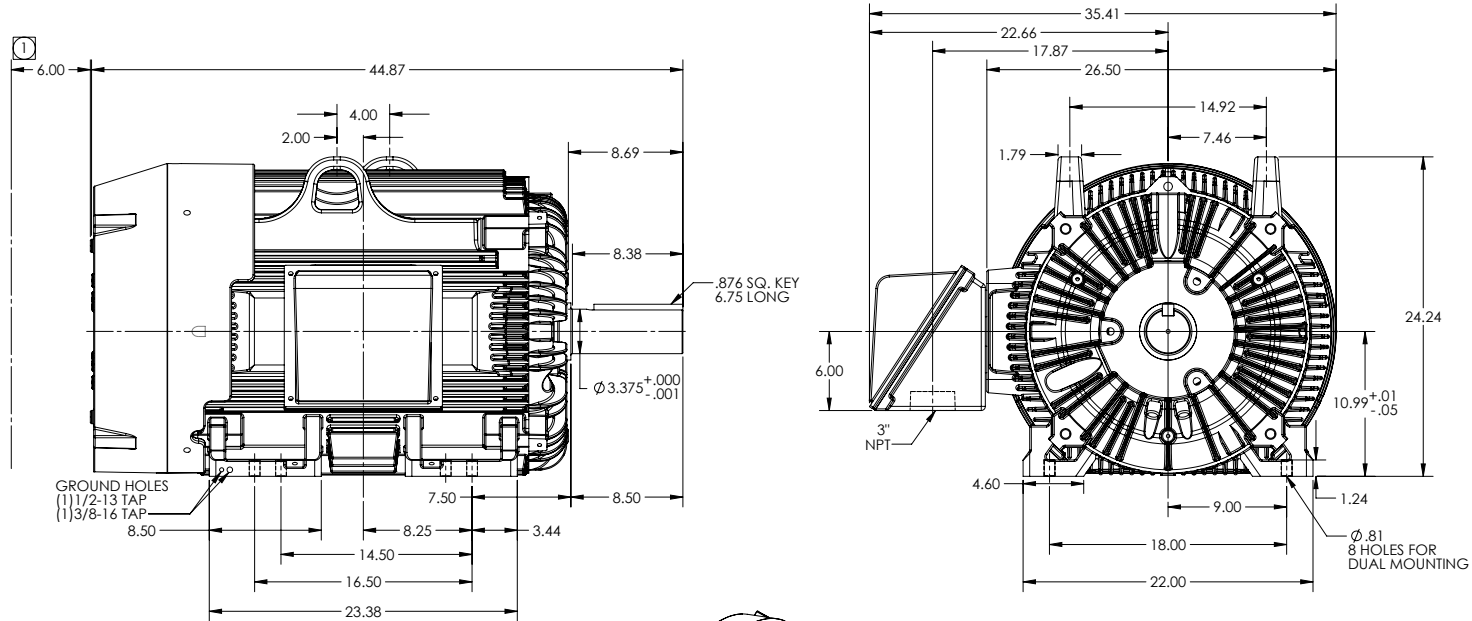

① OBSTRUCTION MUST NOT ENCR OACH ON AIR INLET.
IF MOUNTING CLEARANCE DETAILS ARE REQUIRED, CONSULT FACTORY.
MAXIMUM PERMISSIBLE SHAFT RUNOUT WHEN MEASURED AT END OF STANDARD SHAFT EXTENSION IS .003" T.I.R.
CONDUIT BOX LOCATED ON OPPOSITE SIDE WHEN F-2, W-1, W-4, W-5, W-7, OR C-1 MOUNTING IS SPECIFIED

DIMENSIONS ARE IN INCHES FOR MILLIMETERS SEE SHEET (2)
CUSTOMER IS RESPONSIBLE FOR DETERMINING THAT MOTOR PERFORMANCE IS SUITABLE IN THE APPLICATION.

SHEET NUMBER
1 OF 2
617427-315

REV. DESC: NEW
REV: - VERSION: 00 REVISED: 09/06/36 12/05/2014 TDR: 00000881952
MODEL NO. 617427-315
BY: RAGAJH

BALDOR

G445T/444T STD - FOOTED - SIDE/CENTER C.1 C/B ROLLER BRG

617427-315

DUTY MASTER ALTERNATING CURRENT MOTORS
SQUIRREL-CAGE INDUCTION

617427-315

ENCLOSURE: TOTALLY ENCLOSED

MOUNTING: FOOT

FRAMES G445T/444T

COOLING: FAN COOLED

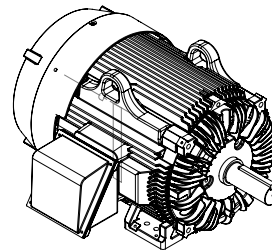
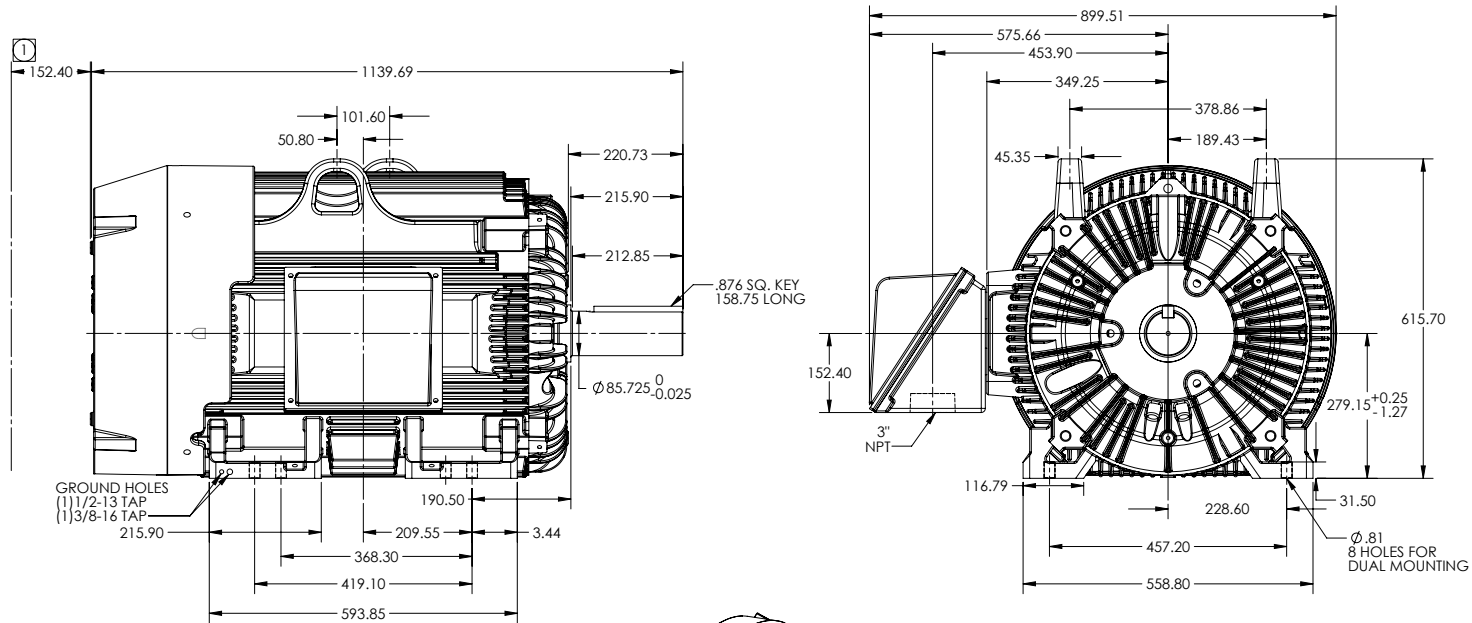

① OBSTRUCTION MUST NOT ENCR OACH ON AIR INLET.
IF MOUNTING CLEARANCE DETAILS ARE REQUIRED, CONSULT FACTORY.
MAXIMUM PERMISSIBLE SHAFT RUNOUT WHEN MEASURED AT END OF STANDARD SHAFT EXTENSION IS .08 T.I.R.
CONDUIT BOX LOCATED ON OPPOSITE SIDE WHEN F-2, W-1, W-4, W-5, W-7, OR C-1 MOUNTING IS SPECIFIED

DIMENSIONS ARE IN MILLIMETERS FOR INCHES SEE SHEET 1
CUSTOMER IS RESPONSIBLE FOR DETERMINING THAT MOTOR PERFORMANCE IS SUITABLE IN THE APPLICATION.

SHEET NUMBER
2 OF 2
617427-315

REV. DESC: NEW	VERSION: 00	REVISED: 09/06/36 12/05/2014	TDR: 00000881952
MODEL NO. 617427-315			
BY: RAGAJH			

BALDOR

G445T/444T STD - FOOTED - SIDE/CENTER C.I. CB ROLLER BRG

617427-315

416820-036

A-C MOTOR
CONNECTION DIAGRAM
STANDARD 3 LEAD CONNECTED

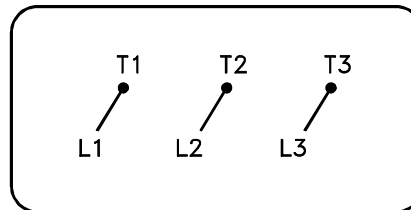

(N.P. 1575-BA)

416820-036

REV. DESC: LOADED TO BUS, C/R 335225		
REV. LTR: -	VERSION: 00	TDR: 000000538207
FILE: \MGA\00000\682	REVISED: 11: 54: 06 04/30/2010	
MTL: -	BY: RAGRA	

BALDOR

CONN DIAG - STANDARD 3 LEAD
SH 1 of 1