

BALDOR • RELIANCE

Customer information packet

ECR93006TR-4

300HP, 1190RPM, 3PH, 60HZ, L 449T, A44192M, TE

Class - None

Division - Not Applicable

Specifications

Enclosure	TEFC
Frame	L449T
Frame Material	Iron
Frequency	60.00 Hz
Motor Letter Type	Three Phase
Output @ Frequency	300.000 HP @ 60 HZ
Phase	3
Synchronous Speed @ Frequency	1200 RPM @ 60 HZ
Voltage @ Frequency	460.0 V @ 60 HZ
XP Class and Group	None
XP Division	Not Applicable
Agency Approvals	CSA EEV
Ambient Temperature	40 °C
Auxillary Box	No Auxillary Box
Base Indicator	Rigid
Bearing Grease Type	Mobil SHC 220 (Athens Only)
Constant Torque Speed Range	30-60
Current @ Voltage	381.000 A @ 460.0 V
Design Code	A
Drip Cover	No Drip Cover
Duty Rating	CONT
Efficiency @ 100% Load	95.8 %
Feedback Device	NO FEEDBACK
Frame Prefix	L
Heater Indicator	No Heater
High Voltage Full Load Amps	381.0 a
Insulation Class	F
Inverter Code	Not Inverter
KVA Code	H
Lifting Lugs	Standard Lifting Lugs
Max Speed	3000 rpm
Motor Lead Quantity/Wire Size	12 @ 2 AWG

Part detail

Revision	J
Type	AC
Mech. spec.	
Base	
Status	PRD/A
Elec. spec.	A44WG5154
Layout	617423-218
Eff. date	04-08-2021
CD Diagram	416820-036
Poles	06
Leads	3#2 (04 per group)
Proprietary	False
Created date	01-26-2015

Motor Standards	NEMA
Motor Type	A44192M
Mounting Arrangement	F1
Number of Poles	6
Overall Length	60.21 IN
Power Factor	77
Product Family	Crusher / Chipper
Pulley End Bearing Type	Roller
Pulley Face Code	Standard
Service Factor	1.15
Shaft Ground Indicator	No Shaft Grounding
Shaft Rotation	Reversible
Shaft Slinger Indicator	Shaft Slinger
Speed	1190 rpm
Speed Code	Single Speed
Starting Method	Direct on line
Thermal Device - Bearing	None
Thermal Device - Winding	None

Nameplate**000613007PV**

CAT NO	ECR93006TR-4		SPEC NO.	P44G1820					
HP	300	AMPS	381	VOLTS	460	DESIGN	A		
RPM	1190	RPM MAX	3000	HZ	60	AMB	40	SF	1.15
D.E. BRG.DATA	NU222	O.D.E. BRG.DATA	6318	PH	3	DUTY	CONT	INSUL.CLASS	F
FRAME	L 449T	I.P.	55	TYPE	P	ENCL	TEFC	CODE	H
POWER FACTOR	77	3/4 LOAD EFF.	95.9	NEMA NOM EFFICIENCY	95.8				
CHP HZ	60-90	CT HZ	30-60	VT HZ	6-60				
SER.NO.				MOTOR WEIGHT					

NP2496L

MOBIL SHC -220 GREASE

Parts list

Part number	Description	Quantity
SA293578	SA P44G1820	1.000 ea
RA279671	RA P44G1820	1.000 ea
000613007PV	SS NP, CRUSHER DUTY, EMBOSSSED,MAIN MOTOR	1.000 ea
000692000FF	N/P	1.000 ea
000692000RT	N/P	1.000 ea
000692000VD	LABEL WARNING	1.000 ea
NP2496L	MOTOR LUBE NAMEPLATE	1.000 ea
004824015AP	GREASE MOBILITH SHC 220	1.156 lb
032018008CK	HHCS 3/8-16X1L PLATED	4.000 ea
032018020FK	HHCS 3/4-10X2-1/2 PLTD.	4.000 ea
032018030DK	HHCS 1/2-13X3-3/4 PLTD.	3.000 ea
032018030DK	HHCS 1/2-13X3-3/4 PLTD.	3.000 ea
034017014AB	LCKW 3/8 STD. PLATED	4.000 ea
034180014DA	KEY 1/4X1/4X1-3/4 L	1.000 ea
034530064AB	P/NIP 1/8 X 8" L Pipe Nipple	1.000 ea
034530064BB	P/NIP 1/4X8 PLATED	1.000 ea
034631002AB	BUSH 1/4 TO 1/8 PLTD.	1.000 ea
035000001G	GREASE RELIEF FITTING, ALEMITE 317400	1.000 ea
035000001G	GREASE RELIEF FITTING, ALEMITE 317400	1.000 ea
083199082A	G28 FAN COVER MACHINING SHORT VERSION	1.000 ea
089490099A	G28 BRKT 089490098WCA KB	1.000 ea
415045002A	SLGR	1.000 ea
415096002A	CPLG 1/8 HEX TYPE	1.000 ea
418151014G	RETAIN RING	1.000 ea
702618012B	FAN 440 702618003T - 2.002 BORE 20.00 D	1.000 ea
032018004BK	HHCS 5/16-18X1/2 PLATED	3.000 ea
032018006BK	HHCS 5/16-18X3/4 PLATED	3.000 ea
032018020FK	HHCS 3/4-10X2-1/2 PLTD.	4.000 ea
034017013AB	LCKW 5/16 STD. PLATED	3.000 ea
034530056AB	1/8 X 7 PP NIPPLE	1.000 ea
034530056BB	P/NIP 1/4X7 SCHED 40	1.000 ea

034631002AB	BUSH 1/4 TO 1/8 PLTD.	1.000 ea
034017013AB	LCKW 5/16 STD. PLATED	3.000 ea
089490101A	G28 BRKT 089490100WCA	1.000 ea
415096002A	CPLG 1/8 HEX TYPE	1.000 ea
418151014H	RETAIN RING	1.000 ea
415915007G	GASK, LAC	1.000 ft
702623013A	THERMAL BARRIER -- G28 -- BRACKET MTD	1.000 ea
702623022A	G28 AIR DEFLECTOR DRIVE END -- PLASTIC	1.000 ea
415045002D	SLGR - 440 V1T45B	1.000 ea
032018008BK	HHCS 5/16-18X1L PLATED	4.000 ea
032018008DK	HHCS 1/2-13X1 PLATED	4.000 ea
032018005DL	1/2-13 X 5/8 SILICON BRONZE HHCS	1.000 ea
035000001A	ALFTG 1/8" 1610-BL	1.000 ea
035000001A	ALFTG 1/8" 1610-BL	1.000 ea
067053014A	GASK 440	1.000 ea
076870000BA	CONDUIT BOX - 440 - 1/2-13 GROUND	1.000 ea
076871000A	+CBOX CVR BLKT - 449	1.000 ea
406056007A	GASKET, 440	1.000 ea
406099000A	PLUG - FAN COVER 320-440	1.000 ea
415000115H	T/LUG #2AWG-4/0AWG	1.000 ea
418150003A	GREASE FITTING CAP	1.000 ea
418150003A	GREASE FITTING CAP	1.000 ea
415030115A	G28 C/BOX 415030114WCA	1.000 ea
032130014DB	HSHCS1/2-13X1-3/4 PLATE	4.000 ea
034000016AB	WSHR .531ID 1.062OD .095	4.000 ea
415039027A	GASKET, G28 LEAD THROAT	1.000 ea
033775004EA	DRSCR #6-1/4 304 S.S.	2.000 ea
034180054KA	7/8 SQ X 6.75 KEY	1.000 ea
MG1025G96	WILKOFASST SG, 779.7048, MOUSE GRAY #7048	0.500 ga
421948051	LABEL, MYLAR	1.000 ea
000613006PU	N/P (RELEASE QTY 10,000) UL CSA LABEL	1.000 ea
034001016AB	WSHR .562ID 1.375OD .109	1.000 ea
034001014AB	FLAT WASHER 3/8"PLATED	1.000 ea
032018028CK	HHCS 3/8-16X3-1/2 PLTD.	1.000 ea

604797001R	440 FR. ROLLER BEARING MOTOR SHAFT	1.000 ea
604799003C	PLASTIC BAG 42X32X46	1.000 ea
033300014AC	HEX NUT, SHIPPING - 400	2.000 ea
034001016AB	WSHR .562ID 1.375OD .109	2.000 ea
034001014AB	FLAT WASHER 3/8"PLATED	2.000 ea
032510026D	CARRIAGE BOLT - 440	2.000 ea
604797032	447/449 WIDE SHIPPING SKID 70" X 55"	1.000 ea
412118006A	DRAIN	2.000 ea

DUTY MASTER ALTERNATING CURRENT MOTORS

SQUIRREL-CAGE INDUCTION

ENCLOSURE: TOTALLY ENCLOSED

FRAME GL449T ABOVE NEMA RATINGS

COOLING: FAN COOLED

MOUNTING: FOOT

INCLUDES G449T FRAME MOUNTING HOLES

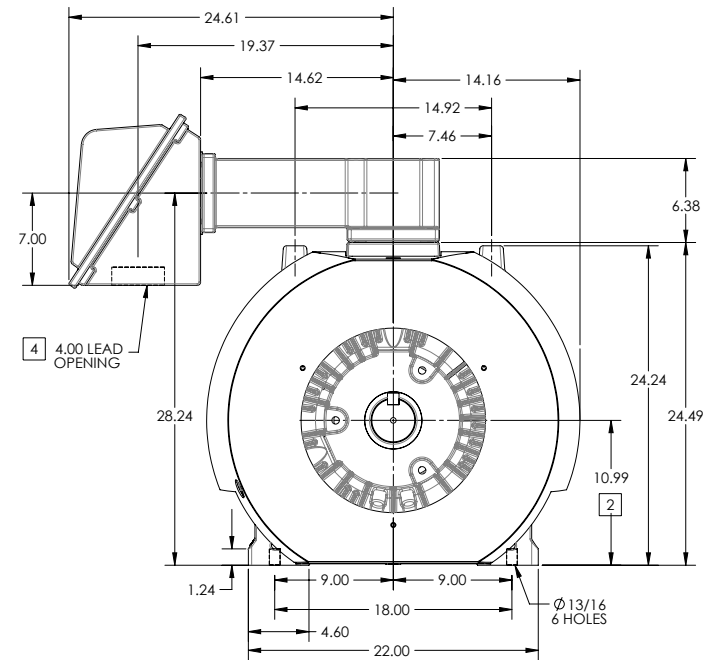
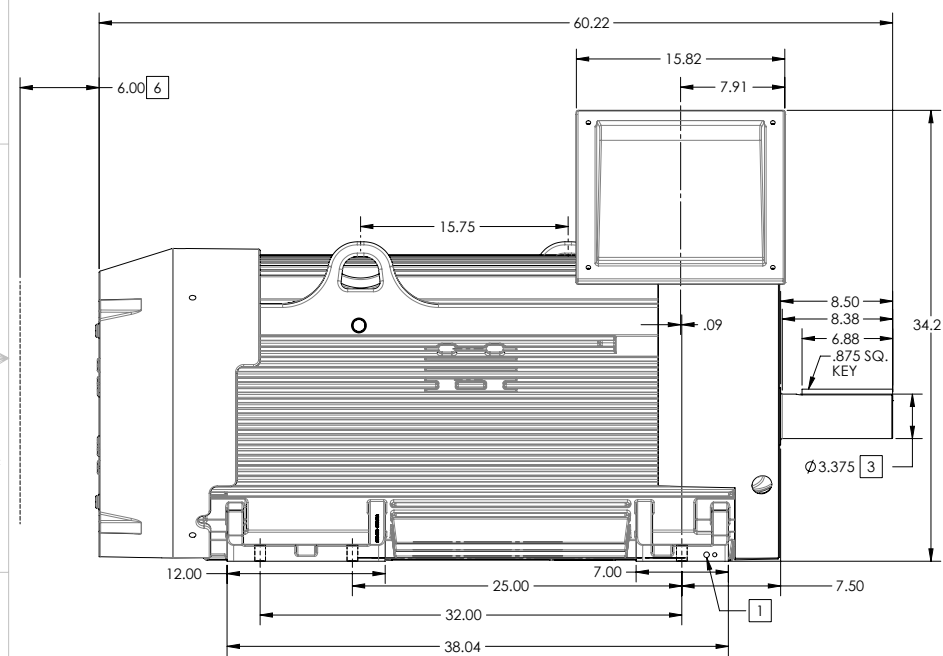

1. GROUND HOLES QTY 1 1/2-13 TAP; QTY 1 3/8-16 TAP
2. VARIES +.00,-.06
3. VARIES +.00,-.001
4. ON STANDARD MOTORS THIS IS CONDUIT SIZE. ON XT AND CORROSION PROOF MOTOR THIS IS PIPE TAP.
5. MOTOR WEIGHTS MAY VARY BY 15% DEPENDING ON RATING.
6. OBSTRUCTION MUST NO ENCROACH ON AIR INLET

CONDUIT BOX LOCATED ON OPPOSITE SIDE WHEN F-2.
IF MOUNTING CLEARANCE DETAILS ARE REQUIRED, CONSULT FACTORY.
MAXIMUM PERMISSIBLE SHAFT RUNOUT WHEN MEASURED AT END OF STANDARD SHAFT EXTENSION IS .003" T.I.R. TO 5 INCH DIA.

WEIGHT (LBS): 3875

DRIVE END AIR DEFLECTOR IS ONLY INCLUDED WHEN NECESSARY.

DIMENSIONS ARE IN INCHES; SEE SHEET 2 FOR DIMENSIONS IN MILLIMETERS

CUSTOMER IS RESPONSIBLE FOR DETERMINING THAT MOTOR PERFORMANCE IS SUITABLE IN THE APPLICATION.

REV. DESC: NEW ISSUE	VERSION: 00	REVISED: 09-28-57 02/11/2015	TDR: 00000884510
MODEL NO. 617423-218			REF:
BY: RAGGDM	Material:		

BALDOR

G28 DIMENSION SHEET ASSEMBLY: GL449449T BA-7.50

617423-218

DUTY MASTER ALTERNATING CURRENT MOTORS

SQUIRREL-CAGE INDUCTION

ENCLOSURE: TOTALLY ENCLOSED

FRAME GL449T ABOVE NEMA RATINGS

COOLING: FAN COOLED

MOUNTING: FOOT

INCLUDES G449T FRAME MOUNTING HOLES

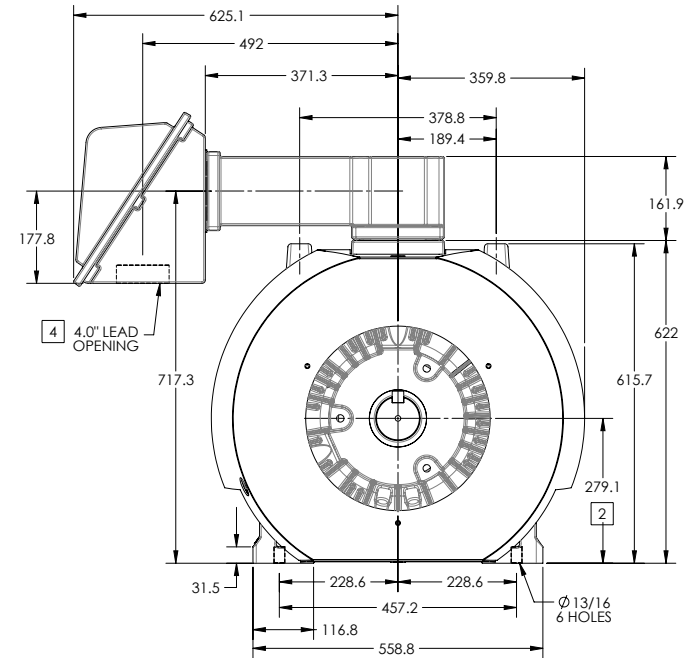
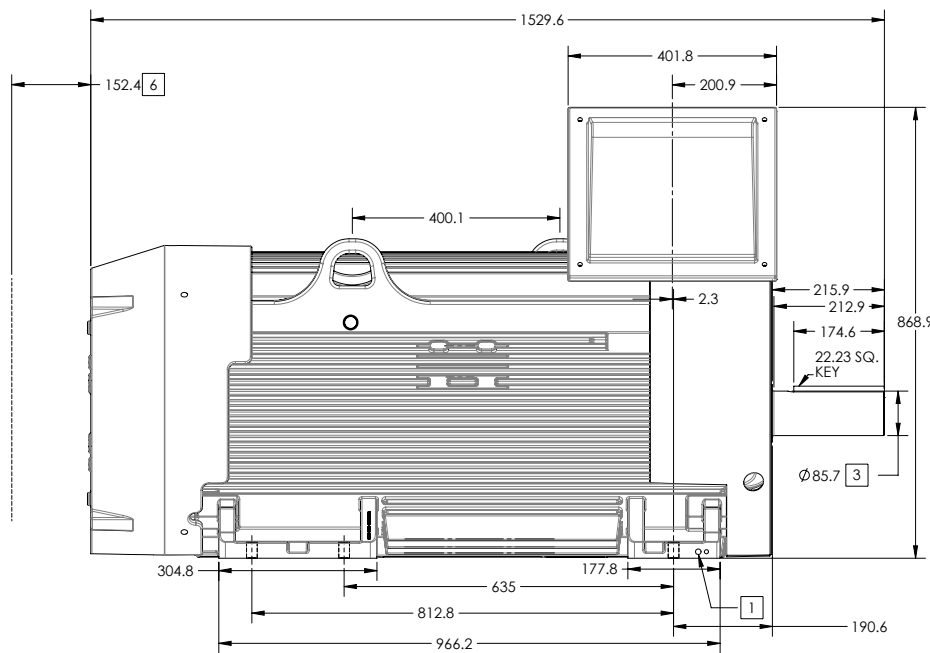

- 1. GROUND HOLES QTY 1 1/2-13 TAP; QTY 1 3/8-16 TAP
- 2. VARIES +.00,-.06
- 3. VARIES +.00,-.001
- 4. ON STANDARD MOTORS THIS IS CONDUIT SIZE. ON XT AND CORROSION PROOF MOTOR THIS IS PIPE TAP.
- 5. MOTOR WEIGHTS MAY VARY BY 15% DEPENDING ON RATING.
- 6. OBSTRUCTION MUST NO ENCROACH ON AIR INLET

CONDUIT BOX LOCATED ON OPPOSITE SIDE WHEN F-2.
IF MOUNTING CLEARANCE DETAILS ARE REQUIRED, CONSULT FACTORY.
MAXIMUM PERMISSIBLE SHAFT RUNOUT WHEN MEASURED AT END OF STANDARD SHAFT EXTENSION IS .08 MM T.I.R. TO 127 MM DIA.

WEIGHT (KGS): 1760

DRIVE END AIR DEFLECTOR IS ONLY INCLUDED WHEN NECESSARY.

DIMENSIONS ARE IN MILLIMETERS; SEE SHEET 1 FOR DIMENSIONS IN INCHES

CUSTOMER IS RESPONSIBLE FOR DETERMINING THAT MOTOR PERFORMANCE IS SUITABLE IN THE APPLICATION.

REV. DESC: NEW ISSUE	VERSION: 00	REVISED: 09-28-57 02/11/2015	TDR: 00000884510
MODEL NO. 617423-218	REF:		
BY: RAGGDM	Material:		

BALDOR

G28 DIMENSION SHEET ASSEMBLY: GL449449T BA-7.50

617423-218

617423-218

416820-036

A-C MOTOR
CONNECTION DIAGRAM
STANDARD 3 LEAD CONNECTED



(N.P. 1575-BA)

416820-036

REV. DESC: LOADED TO BUS, C/R 335225		
REV. LTR: -	VERSION: 00	TDR: 000000538207
FILE: \MGA\00000\682	REVISED: 11: 54: 06 04/30/2010	
MTL: -	BY: RAGRA	

BALDOR

CONN DIAG - STANDARD 3 LEAD
SH 1 of 1