

BALDOR® • RELIANCE 

Product Information Packet

EFM4110T

40HP,1775RPM,3PH,60HZ,324T,1254M,TEFC,F2

Part Detail							
Revision:	Y	Status:	PRD/A	Change #:		Proprietary:	No
Type:	AC	Elec. Spec:	12WGY276	CD Diagram:	CD0180	Mfg Plant:	
Mech. Spec:	12C56	Layout:	12LYC056	Poles:	04	Created Date:	08-09-2011
Base:	RG	Eff. Date:	02-16-2022	Leads:	9#8		

Specs			
Catalog Number:	EFM4110T	Heater Indicator:	No Heater
Enclosure:	TEFC	Insulation Class:	F
Frame:	324T	Inverter Code:	Inverter Ready
Frame Material:	Iron	KVA Code:	H
Output @ Frequency:	40.000 HP @ 60 HZ	Lifting Lugs:	Standard Lifting Lugs
Synchronous Speed @ Frequency:	1800 RPM @ 60 HZ	Locked Bearing Indicator:	Locked Bearing
Voltage @ Frequency:	460.0 V @ 60 HZ	Motor Lead Quantity/Wire Size:	9 @ 8 AWG
	230.0 V @ 60 HZ	Motor Lead Exit:	Ko Box
XP Class and Group:	None	Motor Lead Termination:	Flying Leads
XP Division:	Not Applicable	Motor Type:	1254M
Agency Approvals:	UR	Mounting Arrangement:	F2
	CSA EEV	Power Factor:	82
	CSA	Product Family:	General Purpose
Auxillary Box:	No Auxillary Box	Pulley End Bearing Type:	Ball
Auxillary Box Lead Termination:	None	Pulley Face Code:	Standard
Base Indicator:	Rigid	Pulley Shaft Indicator:	Standard
Bearing Grease Type:	Polyrex EM (-20F +300F)	Rodent Screen:	None
Blower:	None	Shaft Extension Location:	Pulley End

Current @ Voltage:	102.000 A @ 208.0 V	Shaft Ground Indicator:	No Shaft Grounding
	48.000 A @ 460.0 V	Shaft Rotation:	Reversible
	96.000 A @ 230.0 V	Shaft Slinger Indicator:	Shaft Slinger
Design Code:	A	Speed Code:	Single Speed
Drip Cover:	No Drip Cover	Motor Standards:	NEMA
Duty Rating:	CONT	Starting Method:	Direct on line
Electrically Isolated Bearing:	Not Electrically Isolated	Thermal Device - Bearing:	None
Feedback Device:	NO FEEDBACK	Thermal Device - Winding:	None
Front Face Code:	Standard	Vibration Sensor Indicator:	No Vibration Sensor
Front Shaft Indicator:	None	Winding Thermal 1:	None
		Winding Thermal 2:	None

Nameplate NP3443LUA										
CAT.NO.	EFM4110T				CUST. P/N				ENCL	TEFC
SPEC.	12C056Y276G2		CC	010A	FRAME	324T		SER.NO.		
HP	40		CLASS	F	HZ	60				
R.P.M.	1775		PH.	3	DES.	A				
VOLTS	230/460			CODE	H	ODE BRG	6311	DE BRG	6312	
AMPS	96/48			USABLE AT 208V	102					
RATING	40C AMB-CONT			NEMA NOM. EFF.	94.1		GREASE	POLYREX EM		
P.F.	82	SER.F.	1.15		CT6-60H(10:1)VT3-60H(20:1)					
USABLE AT	50HZ 40HP 190/380V 114/57A				SF1.0					
VOLTS		AMPS		MAX. SPACE HEATER TEMP.						

Parts List		
Part Number	Description	Quantity
SA229244	SA 12C056Y276G2	1.000 EA
RA216294	RA 12C056Y276G2	1.000 EA
09FN3001B03SP	EXTERNAL FAN, PLASTIC (COMES W/SCREW FRO	1.000 EA
10CB3001	CONDUIT BOX CAST W/2.500 LEAD HOLE	1.000 EA
09GS1000SP	GASKET-CONDUIT BOX, 1/16 THICK LEXIDE	1.000 EA
10XN3118K12	5/16-18 X .75 GRADE 5, ZINC PLATED	4.000 EA
HW1001A31	LOCKWASHER 5/16, ZINC PLT.591 OD, .319 I	4.000 EA
WD1000B25	GND LUG, BURNDY L125HP OR T&B L125HP-BB	1.000 EA
19XW3118G08	.31-18X.50,HEX WSHR HD,TAPTITE 2,GREEN	1.000 EA
12EP1107A05	FR ENDPLATE, MACH	1.000 EA
HA4051A00	PLASTIC CAP FOR GREASE FITTING	1.000 EA
HA3400A13	STUD, 1/2-13 X 7" WELKER	4.000 EA
HW1001A50	LOCKWASHER 1/2, ZINC PLT.,.879 OD, .509 I	4.000 EA
HW4600B41	V-RING SLINGER 2.125 X 2.880 X 0.280	1.000 EA
HW5100A13	W4627-047 WVY WSHER	1.000 EA
12EP1106A01	PU ENDPLATE, MACH	1.000 EA
HA4051A00	PLASTIC CAP FOR GREASE FITTING	1.000 EA
10XN3118K40	5/16-18 X 2.25" HEX HD, GRADE 5	2.000 EA
HW1001A31	LOCKWASHER 5/16, ZINC PLT.591 OD, .319 I	2.000 EA
10XN3118K40	5/16-18 X 2.50" HEX HD, GRADE 5	4.000 EA
HW1001A31	LOCKWASHER 5/16, ZINC PLT.591 OD, .319 I	4.000 EA
10XN5013K28	1/2-13 X 1.75 HEX HEAD MACH SCREW,GRAD	4.000 EA
HW1001A50	LOCKWASHER 1/2, ZINC PLT.,.879 OD, .509 I	4.000 EA
12FH1002SP	FAN COVER, CAST	1.000 EA

Parts List (continued)		
Part Number	Description	Quantity
XY5013A12	NUT,1/2-13,HEX,STEEL,ZINCPLATED	4.000 EA
HW1001A50	LOCKWASHER 1/2, ZINC PLT.,.879 OD, .509 I	4.000 EA
10CB3500SP	CONDUIT BOX LID, CAST	1.000 EA
10GS1000SP	GASKET, CONDUIT BOX LID	1.000 EA
51XW2520A12	.25-20 X .75, TAPTITE II, HEX WSHR SLTD	4.000 EA
HW2501H33	KEY, 1/2 SQ X 3.875	1.000 EA
LB1115N	LABEL,LIFTING DEVICE (ON ROLLS)	1.000 EA
HW4500A21	1618BALEMITE FITTING 825 UNIVERSAL	1.000 EA
HA4017A01	1/8 X 4 GREASE EXT (F/S)	1.000 EA
HW4500A17	317400 ALEMITE GREASE RELIEF	1.000 EA
HA4054	SHORT T-DRAIN FITTING, .125" N.P.T.	1.000 EA
MJ1000A02	GREASE, MOBIL POLYREX EM - 124047	0.200 LB
HW4500A03	GREASE FITTING, .125 NPT 1610(ALEMITE) 8	1.000 EA
HW4500A17	317400 ALEMITE GREASE RELIEF	1.000 EA
HA4054	SHORT T-DRAIN FITTING, .125" N.P.T.	1.000 EA
HW2500A25	WOODRUFF KEY USA #1008 #BLOW CARBON STEE	1.000 EA
51XB1214A20	12-14X1.25 HXWSSLD SERTYB	1.000 EA
MG1000Y03	MUNSELL 2.53Y 6.70/ 4.60, GLOSS 20,	0.080 GA
85XU0407S04	4X1/4 U DRIVE PIN STAINLESS	4.000 EA
MN416A01	TAG-INSTAL-MAINT no wire (2100/bx) 4/22	1.000 EA
LB1119N	WARNING LABEL	1.000 EA
LC0181	CONNECTION LABEL	1.000 EA
NP3443LUA	SS SUPER-E UL CSA-EEV PREM CC	1.000 EA
12PA1000	PACKAGING GROUP PRINT PK1024A07	1.000 EA

PE-0000013	ZRTG PE ASSEMBLY	1.000 EA
FE-0000022	ZRTG FE ASSEMBLY	1.000 EA

AC Induction Motor Performance Data

Record # 31673

Typical performance - not guaranteed values

Winding: 12WGY276-R001		Type: 1254M		Enclosure: TEFC	
Nameplate Data			460 V, 60 Hz: High Voltage Connection		
Rated Output (HP)	40	Full Load Torque	119 LB-FT		
Volts	230/460	Start Configuration	direct on line		
Full Load Amps	96/48	Breakdown Torque	396 LB-FT		
R.P.M.	1775	Pull-up Torque	198 LB-FT		
Hz	60 Phase	Locked-rotor Torque	222 LB-FT		
NEMA Design Code	A KVA Code	Starting Current	347 A		
Service Factor (S.F.)	1.15	No-load Current	21.03 A		
NEMA Nom. Eff.	94.1 Power Factor	Line-line Res. @ 25°C	0.139 Ω		
Rating - Duty	40C AMB-CONT	Temp. Rise @ Rated Load	54°C		
S.F. Amps		Temp. Rise @ S.F. Load	66°C		
		Locked-rotor Power Factor	27.1		
		Rotor inertia	7.19 lb-ft ²		

Load Characteristics 460 V, 60 Hz, 40 HP

% of Rated Load	25	50	75	100	125	150	S.F.
Power Factor	45	67	77	82	84	85	83
Efficiency	89.8	93.4	94.1	94.4	93.9	93.1	94.1
Speed	1794	1788	1783	1777	1771	1765	1773
Line amperes	23.93	30.4	39.12	48.68	59.71	71.22	55.3

Performance Graph at 460V, 60Hz, 40.0HP Typical performance - Not guaranteed values

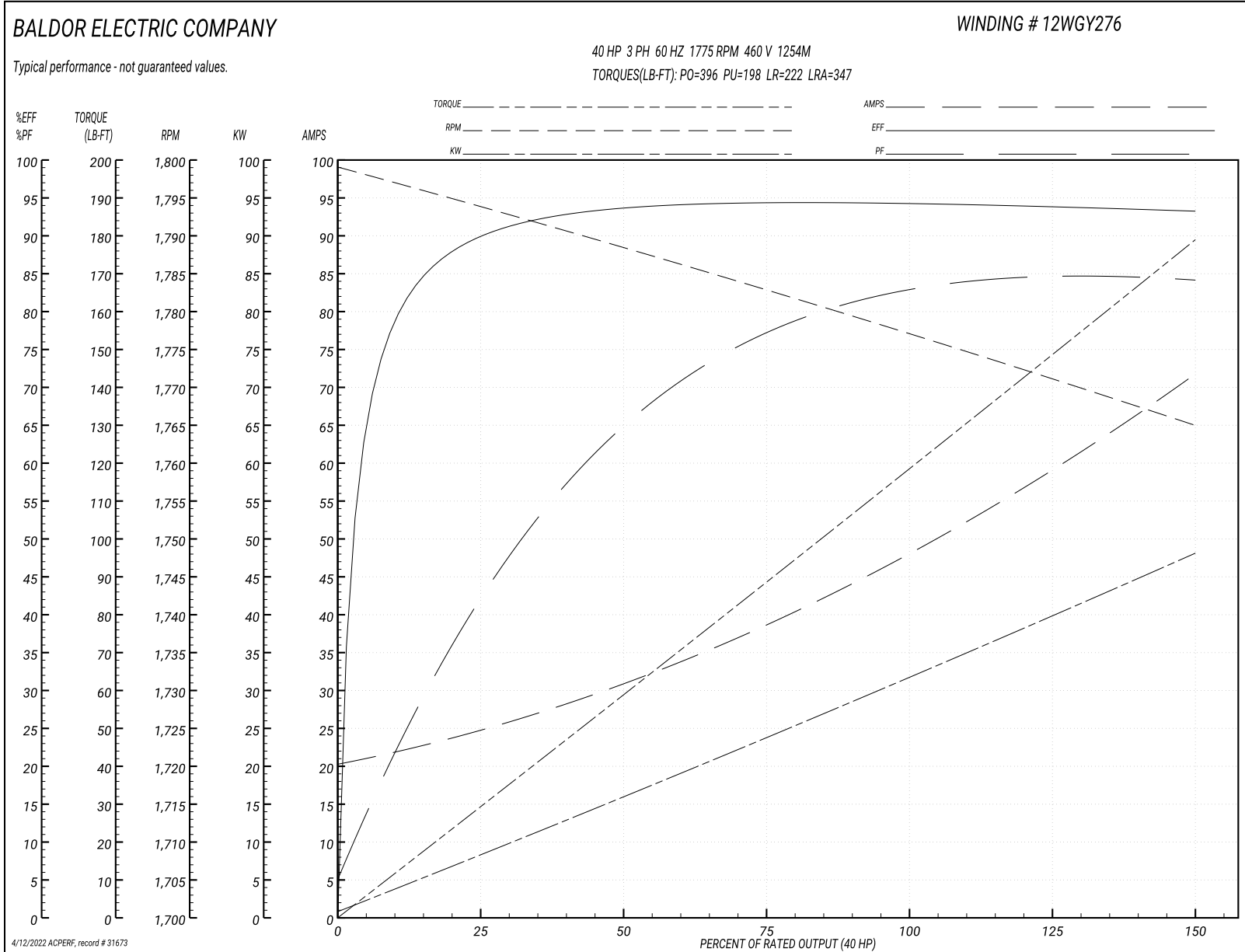

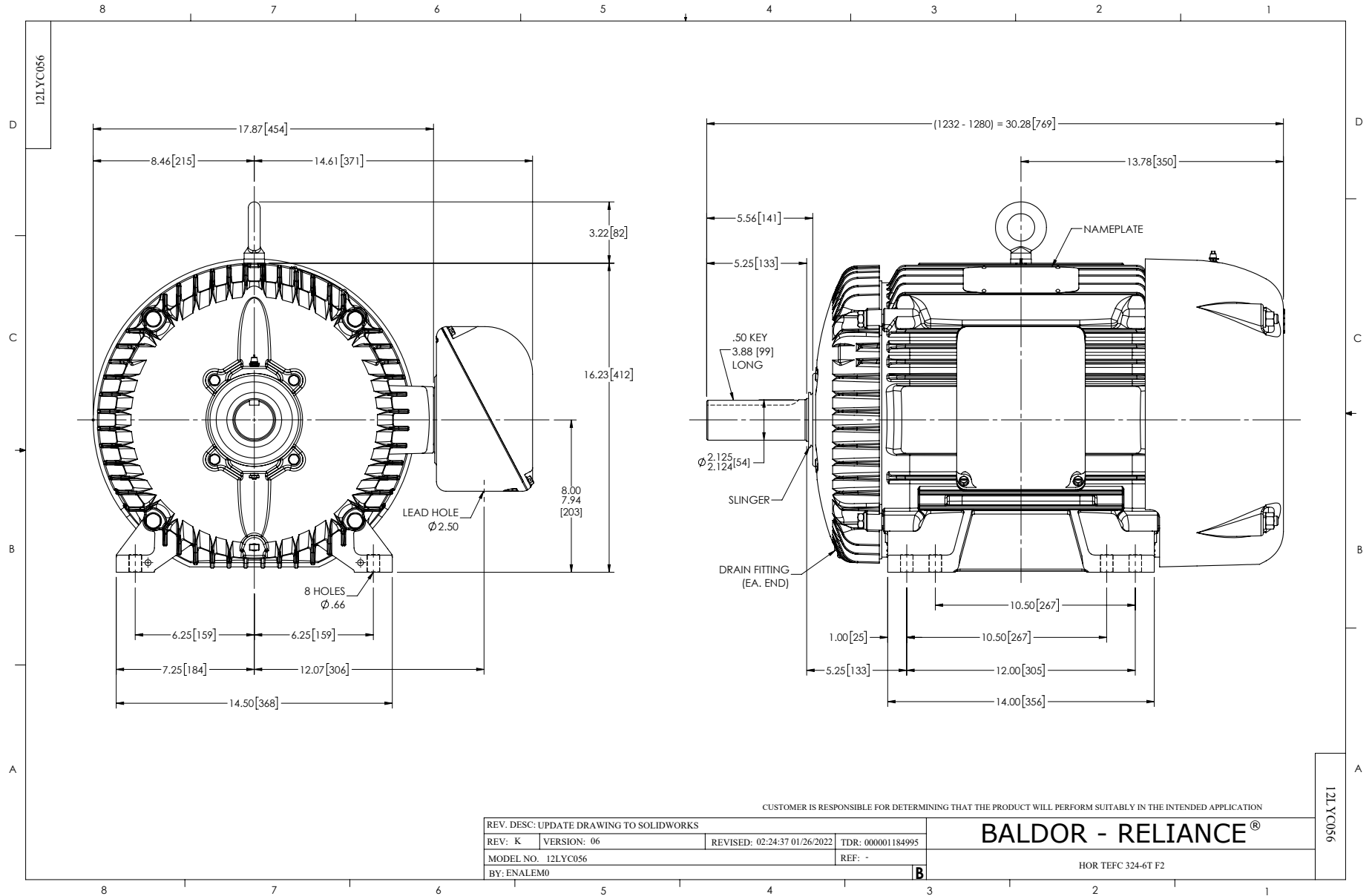

CD0180

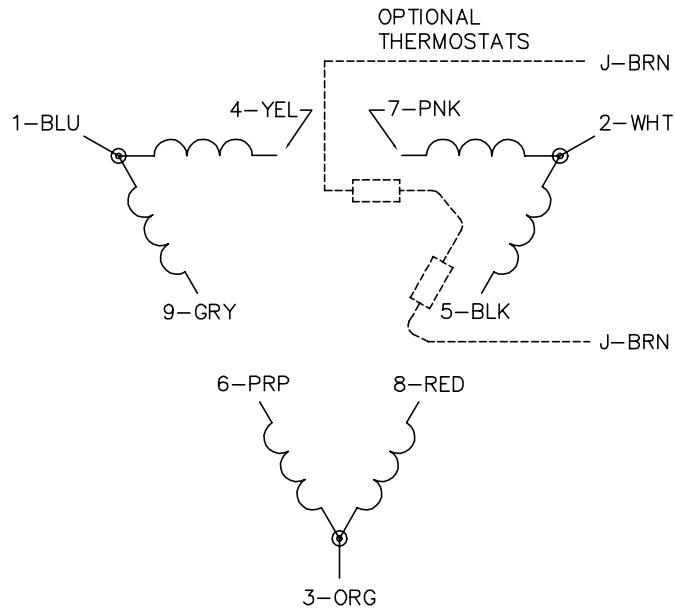

LOW VOLTAGE
(2D)

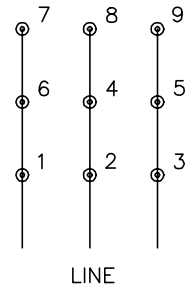

HIGH VOLTAGE
(1D)

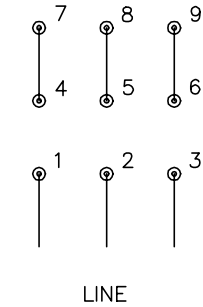

NOTES:

1. INTERCHANGE ANY TWO LINE LEADS TO REVERSE ROTATION.
2. OPTIONAL THERMOSTATS ARE PROVIDED WHEN SPECIFIED.
3. ACTUAL NUMBER OF INTERNAL PARALLEL CIRCUITS MAY BE A MULTIPLE OF THOSE SHOWN ABOVE.
4. LEAD COLORS ARE OPTIONAL. LEADS MUST ALWAYS BE NUMBERED AS SHOWN.

CD0180

REV. DESC: ADD CLASS CONN00000007		
REV. LTR: D	VERSION: 01	TDR: 000001099922
FILE: \AAA\00005\148	REVISED: 10:25:29 02/19/2019	BY: ENBRIRO
MTL: -	© □	

BALDOR - RELIANCE®

3PH, DV, 9 LEADS, DELTA CONNECTION

SH 1 of 1

Marketing maintained PDF of MN416:

<http://www.baldor.com/support/Literature/Load.ashx/MN416?ManNumber=MN416>