

**BALDOR® • RELIANCE™**

---

# Customer information packet

## EFM4400T

100HP, 1785RPM, 3PH, 60HZ, 405T, A40064M, TEFC

Class - None

Division - Not Applicable

## Specifications

Enclosure	TEFC
Frame	405T
Frame Material	Iron
Frequency	60.00 Hz
Motor Letter Type	Three Phase
Output @ Frequency	100.000 HP @ 60 HZ
Phase	3
Synchronous Speed @ Frequency	1800 RPM @ 60 HZ
Voltage @ Frequency	230.0 V @ 60 HZ 460.0 V @ 60 HZ
XP Class and Group	None
XP Division	Not Applicable
Agency Approvals	CSA EEV CCSA US
Ambient Temperature	40 °C
Auxillary Box	No Auxillary Box
Base Indicator	Rigid
Bearing Grease Type	Polyrex EM (-20F +300F)
Current @ Voltage	224.000 A @ 230.0 V 112.000 A @ 460.0 V
Design Code	B
Drip Cover	No Drip Cover
Duty Rating	CONT
Efficiency @ 100% Load	95.4 %
Feedback Device	NO FEEDBACK
Heater Indicator	No Heater
High Voltage Full Load Amps	112.0 a
Insulation Class	F
Inverter Code	Inverter Ready
KVA Code	G
Lifting Lugs	Standard Lifting Lugs
Motor Lead Quantity/Wire Size	3 @ 2 AWG

## Part detail

Revision	H
Type	AC
Mech. spec.	
Base	
Status	PRD/A
Elec. spec.	A40WG0251
Layout	617429-011
Eff. date	04-08-2021
CD Diagram	416820-002
Poles	04
Leads	3#2,6#4
Proprietary	False
Created date	07-16-2013

<b>Motor Standards</b>	NEMA
<b>Motor Type</b>	A40064M
<b>Mounting Arrangement</b>	F2
<b>Number of Poles</b>	4
<b>Overall Length</b>	38.04 IN
<b>Power Factor</b>	87
<b>Pulley End Bearing Type</b>	Ball
<b>Pulley Face Code</b>	Standard
<b>Service Factor</b>	1.15
<b>Shaft Ground Indicator</b>	No Shaft Grounding
<b>Shaft Rotation</b>	Reversible
<b>Shaft Slinger Indicator</b>	No Slinger
<b>Speed</b>	1785 rpm
<b>Speed Code</b>	Single Speed
<b>Starting Method</b>	Direct on line
<b>Thermal Device - Bearing</b>	None
<b>Thermal Device - Winding</b>	None

**Nameplate**

**NP2383L**

<b>CAT.NO.</b>	EFM4400T	<b>SPEC NO.</b>	P40G3924						
<b>HP</b>	100	<b>AMPS</b>	224/112		<b>VOLTS</b>	230/460	<b>DESIGN</b>	B	
<b>FRAME</b>	405T	<b>RPM</b>	1785	<b>HZ</b>	60	<b>AMB</b>	40	<b>SF</b>	1.15
<b>DRIVE END BEARING</b>	80BC03J30X	<b>PHASE</b>	3	<b>DUTY</b>	CONT	<b>INSUL.CLASS</b>	F		
<b>OPP D.E. BEARING</b>	80BC03J30X	<b>TYPE</b>	P	<b>ENCL</b>	TEFC	<b>CODE</b>	G		
<b>SER.NO.</b>		<b>POWER FACTOR</b>	87		<b>NEMA-NOM-EFFICIENCY</b>	95.4			
<b>NEMA NOM/CSA QUOTED EFF</b>		<b>MAX CORR KVAR</b>	18		<b>GUARANTEED EFFICIENCY</b>	94.5			
		<b>MOTOR WEIGHT</b>	1204						

---

**NP2496L**

---

MOBIL POLYREX EM

---

## Parts list

Part number	Description	Quantity
SA267713	SA P40G3924	1.000 ea
RA254383	RA P40G3924	1.000 ea
000613006PU	N/P (RELEASE QTY 10,000) UL CSA LABEL	1.000 ea
000692000VD	LABEL WARNING	1.000 ea
000692000FF	N/P	1.000 ea
NP2383L	SUPER-E ,SS, CC, CSA-C US, CSA EEV	1.000 ea
421948032	LABEL, MYLAR	1.000 ea
412118006A	DRAIN	2.000 ea
004824015A	GREASE POLYREX EM	0.884 lb
032018008CK	HHCS 3/8-16X1L PLATED	4.000 ea
032018008CK	HHCS 3/8-16X1L PLATED	4.000 ea
032018020EK	HHCS 5/8-11X2-1/2 PLTD.	4.000 ea
032018024CK	HHCS 3/8-16X3 PLTD.	3.000 ea
034000014AB	WSH ID.406 OD.812 TH.065	4.000 ea
034180012DA	KEY 1X4X1/4X1-1/2 L	1.000 ea
034530052AB	P/NIP 1/8X6-1/2 Zinc	1.000 ea
034530056BB	P/NIP 1/4X7 SCHED 40	1.000 ea
034631002AB	BUSH 1/4 TO 1/8 PLTD.	1.000 ea
034692005AA	P PLUG 3/4"BLK.	1.000 ea
034690001AB	1/8" NPT SQHDPLG	1.000 ea
078548001R	FAN KB 234/150 (84) 400	1.000 ea
083198127A	G400 MOLDED FAN COVER	1.000 ea
089412501A	BRKT FTMT G400 FIN MACH 6316 89412500WCA	1.000 ea
410700000DA	WAVY SPRING WASHER	1.000 ea
415072001B	CLAMP	1.000 ea
415096002A	CPLG 1/8 HEX TYPE	1.000 ea
032018020EK	HHCS 5/8-11X2-1/2 PLTD.	4.000 ea
032018024CK	HHCS 3/8-16X3 PLTD.	3.000 ea
034690002AB	PPLG 1/4" PLTD.	1.000 ea
089412501A	BRKT FTMT G400 FIN MACH 6316 89412500WCA	1.000 ea
032018005AK	HHCS 1/4-20X5/8 PLATED	4.000 ea

035000001A	ALFTG 1/8" 1610-BL	1.000 ea
035000001A	ALFTG 1/8" 1610-BL	1.000 ea
043292000AJ	GASK 320-400	1.000 ea
077176000L	C/BOX, PAINTED 440	1.000 ea
077176001A	CBOXC, PAINTED 360-400	1.000 ea
402731001A	GASK 360-440	1.000 ea
406099000A	PLUG - FAN COVER 320-440	1.000 ea
415000115H	T/LUG #2AWG-4/0AWG	1.000 ea
418150003A	GREASE FITTING CAP	1.000 ea
MG1025Y17	WILKOFAS, 789.701, SUPER E PEARL GOLD	0.375 ga
418150003A	GREASE FITTING CAP	1.000 ea
033775004EA	DRSCR #6-1/4 304 S.S.	2.000 ea
034180044JA	KEY 3/4X3/4X5-1/2 L	1.000 ea
032018005DL	1/2-13 X 5/8 SILICON BRONZE HHCS	1.000 ea
PK5004A02	WOOD BASE 40X32 STACK 2X4 RUNNER	1.000 ea
NP2496L	MOTOR LUBE NAMEPLATE	1.000 ea

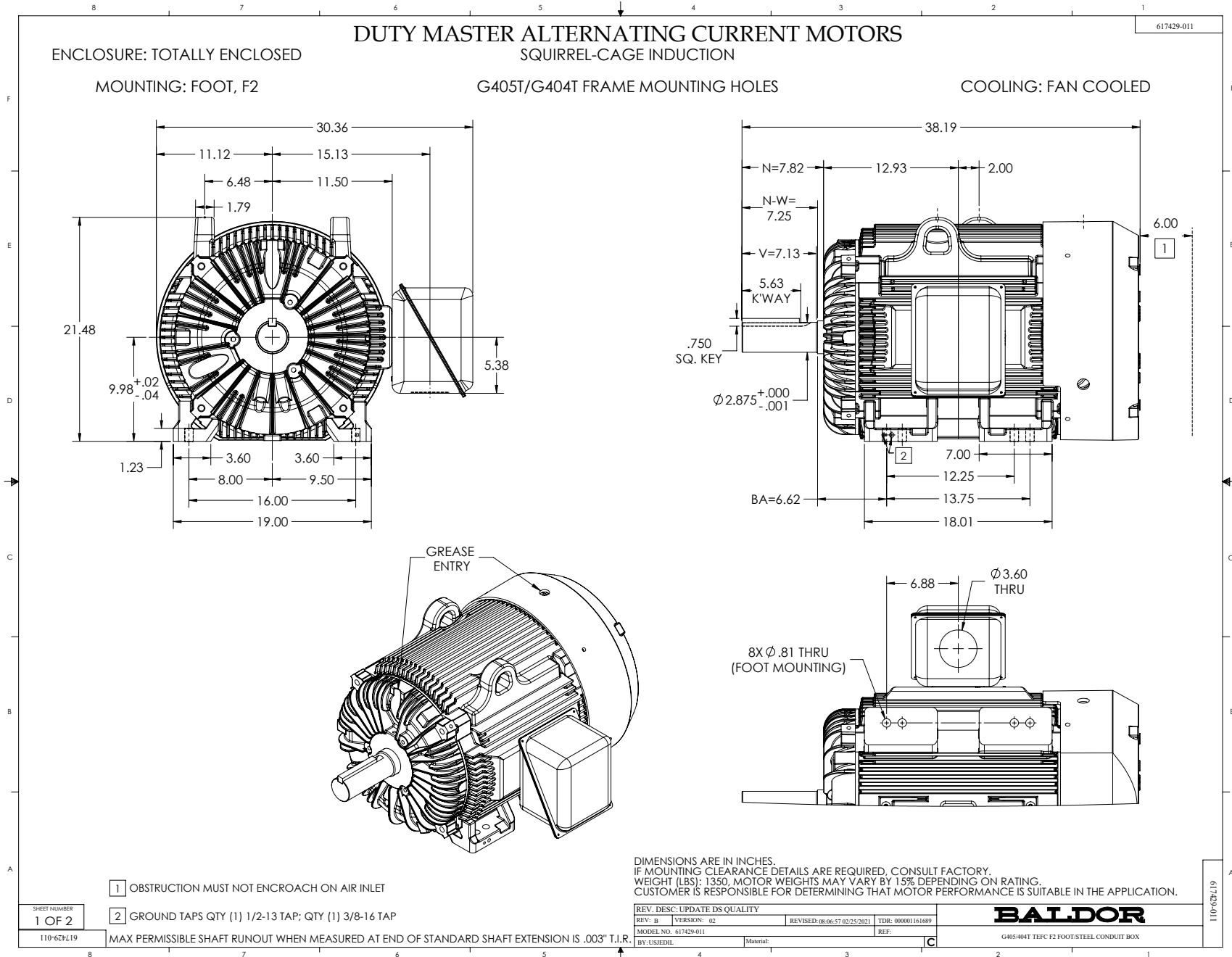



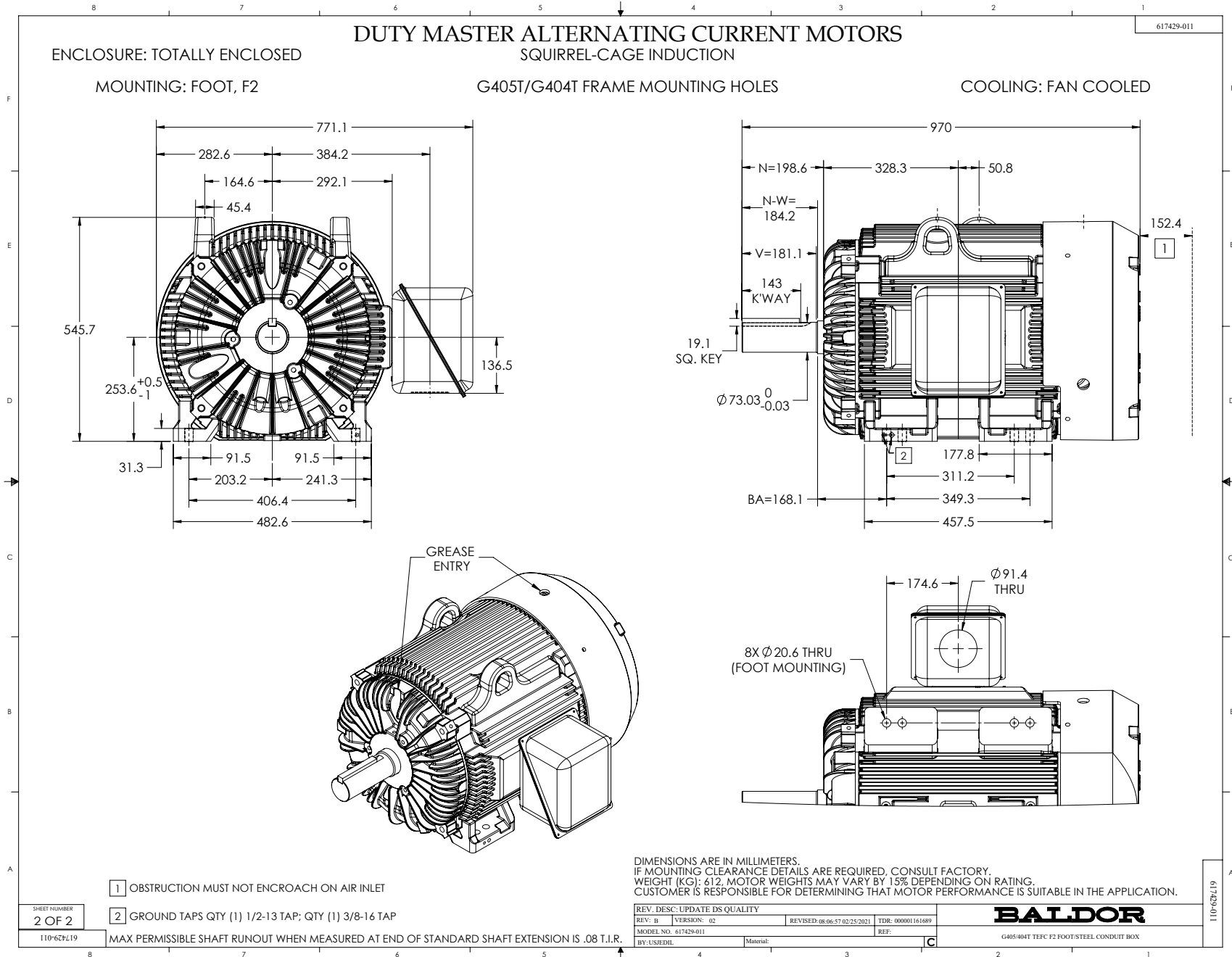

416820-002

A-C MOTOR  
 CONNECTION DIAGRAM  
 STANDARD 9 LEAD DELTA-CONNECTED

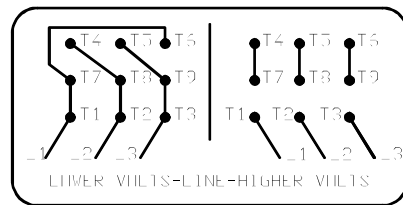
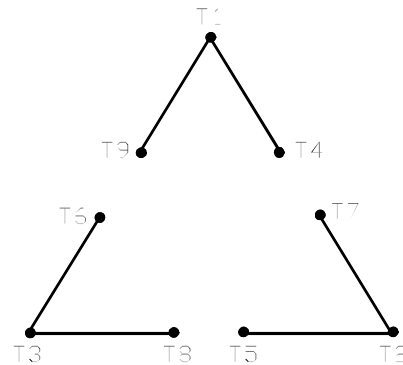

(N.P. 1575-B)

416820-002

REV. DESC: FONT CHANGE FOR PDF SEARCHABLE		
REV. LTR: A	VERSION: 01	TDR: 000001009382
FILE: \MGA\00000\661	REVISED: 02:46:19 02/13/2020	BY: MGHMTT
MTL: -	© □	

**BALDOR - RELIANCE®**

CONN DIAG - STANDARD 9 LEAD, DELTA-CONNECTED

SH 1 of 1