

BALDOR® • RELIANCE 

Product Information Packet

EHM2276T

7.5HP, 1180RPM, 3PH, 60HZ, 254T, 0954M, TEFC, F

Part Detail							
Revision:	S	Status:	PRD/A	Change #:		Proprietary:	No
Type:	AC	Elec. Spec:	09WGT118	CD Diagram:	CD0005	Mfg Plant:	
Mech. Spec:	09J970	Layout:	09LYJ970	Poles:	06	Created Date:	10-03-2014
Base:	RG	Eff. Date:	02-28-2022	Leads:	9#12		

Specs			
Catalog Number:	EHM2276T	Heater Indicator:	No Heater
Enclosure:	TEFC	Insulation Class:	F
Frame:	254T	Inverter Code:	Inverter Ready
Frame Material:	Iron	KVA Code:	J
Output @ Frequency:	7.500 HP @ 60 HZ	Lifting Lugs:	Standard Lifting Lugs
Synchronous Speed @ Frequency:	1200 RPM @ 60 HZ	Locked Bearing Indicator:	Locked Bearing
Voltage @ Frequency:	460.0 V @ 60 HZ	Motor Lead Quantity/Wire Size:	9 @ 12 AWG
	230.0 V @ 60 HZ	Motor Lead Exit:	Ko Box
XP Class and Group:	None	Motor Lead Termination:	Flying Leads
XP Division:	Not Applicable	Motor Type:	0954M
Agency Approvals:	UR	Mounting Arrangement:	F1
	CSA EEV	Power Factor:	70
	CSA	Product Family:	General Purpose
Auxillary Box:	No Auxillary Box	Pulley End Bearing Type:	Ball
Auxillary Box Lead Termination:	None	Pulley Face Code:	Standard
Base Indicator:	Rigid	Pulley Shaft Indicator:	Standard
Bearing Grease Type:	Polyrex EM (-20F +300F)	Rodent Screen:	None
Blower:	None	Shaft Extension Location:	Pulley End

Current @ Voltage:	11.000 A @ 460.0 V	Shaft Ground Indicator:	Mounting Provisions Only
	22.000 A @ 230.0 V	Shaft Rotation:	Reversible
	23.000 A @ 208.0 V	Shaft Slinger Indicator:	No Slinger
Design Code:	A	Speed Code:	Single Speed
Drip Cover:	No Drip Cover	Motor Standards:	NEMA
Duty Rating:	CONT	Starting Method:	Direct on line
Electrically Isolated Bearing:	Not Electrically Isolated	Thermal Device - Bearing:	None
Feedback Device:	NO FEEDBACK	Thermal Device - Winding:	None
Front Face Code:	Standard	Vibration Sensor Indicator:	No Vibration Sensor
Front Shaft Indicator:	None	Winding Thermal 1:	None
		Winding Thermal 2:	None

Nameplate NP1259L										
CAT.NO.	EHM2276T									
SPEC.	09J970T118G1									
HP	7.5									
VOLTS	230/460									
AMP	22/11									
RPM	1180									
FRAME	254T				HZ	60			PH	3
SER.F.	1.15		CODE	J	DES	A		CL	F	
NEMA-NOM-EFF	91		PF	70						
RATING	40C AMB-CONT									
CC	010A				USABLE AT 208V			23		
DE	6309				ODE	6208				
ENCL	TEFC		SN							
	SFA 24.5/12.3									

Parts List		
Part Number	Description	Quantity
SA287844	SA 09J970T118G1	1.000 EA
RA274047	RA 09J970T118G1	1.000 EA
HW1002A63	WASHER, 5/8 HI-COLLAR SPRICKWASHER	1.000 EA
09CB3003	CB W/1.75" DIA LD HL - 37, 39, 307 & 309	1.000 EA
09GS1000SP	GASKET-CONDUIT BOX, 1/16 THICK LEXIDE	1.000 EA
51XW2520A12	.25-20 X .75, TAPTITE II, HEX WSHR SLTD	4.000 EA
HW1001A25	LOCKWASHER 1/4, ZINC PLT .493 OD, .255 I	2.000 EA
09EP1101A132	PU ENDPLATE, MACH	1.000 EA
10XN3816K28	3/8-16 X 1.75 HEX HD CAP SCREW, GRADE 5	4.000 EA
WD1000B16	T&B CX70TN OR L70P TERMINAL LUG	1.000 EA
59XW2520G07	.25-20X.44,HEX SER WSHR,TAPTITE 2,GREEN	1.000 EA
09EP1100A14	FREP ASSM, (FOR INTRL ROUTING PURPOSE)	1.000 EA
HA3400A33	STUD- 3/8-16 X 4.82 HEX WELKER	4.000 EA
XY3816A12	3/8-16 FINISHED NUT	4.000 EA
HW1001A38	LOCKWASHER 3/8, ZINC PLT .688 OD, .382 I	4.000 EA
HW5100A08	W3118-035 WVY WSHR (WB)	1.000 EA
10XN2520K28	1/4-20 X 1.75" HX HD SCRWGRADE 5, ZINC P	2.000 EA
84XN0540J08	5-40 X 1/2" SHCS, BLACK OXIDE	2.000 EA
10XN2520K36	1/4-20 X 2.25" HX HD SCRWGRADE 5, ZINC P	4.000 EA
HW1001A25	LOCKWASHER 1/4, ZINC PLT .493 OD, .255 I	4.000 EA
HW1001A38	LOCKWASHER 3/8, ZINC PLT .688 OD, .382 I	4.000 EA
09FH4000SP	309 FH - BLACK PRIMER	1.000 EA
HW1001A38	LOCKWASHER 3/8, ZINC PLT .688 OD, .382 I	4.000 EA
09CB3501SP	CONDUIT BOX LID FOR 09CB3001 & 09CB3002	1.000 EA

Parts List (continued)		
Part Number	Description	Quantity
09GS1013SP	GS FOR 09CB3501, 12CB1500 & 12CB1503 LID	1.000 EA
51XW2520A12	.25-20 X .75, TAPTITE II, HEX WSHR SLTD	2.000 EA
HW2501G25	KEY, 3/8 SQ X 2.875	1.000 EA
LB1115N	LABEL,LIFTING DEVICE (ON ROLLS)	1.000 EA
HA4051A00	PLASTIC CAP FOR GREASE FITTING	1.000 EA
HW4500A20	1/8NPT SL PIPE PLUG	1.000 EA
HW4500A20	1/8NPT SL PIPE PLUG	1.000 EA
HA4054	SHORT T-DRAIN FITTING, .125" N.P.T.	1.000 EA
MJ1000A02	GREASE, MOBIL POLYREX EM - 124047	0.080 LB
HA4051A00	PLASTIC CAP FOR GREASE FITTING	1.000 EA
HW4500A20	1/8NPT SL PIPE PLUG	1.000 EA
HW4500A20	1/8NPT SL PIPE PLUG	1.000 EA
HA4054	SHORT T-DRAIN FITTING, .125" N.P.T.	1.000 EA
09FN3001D01SP	EXTERNAL FAN, PLASTIC (COMES W/SCREW FRO	1.000 EA
HW2500A25	WOODRUFF KEY USA #1008 #BLOW CARBON STEE	1.000 EA
MG1000G27	MED CHARCOAL METALLIC GREY 400-0096	0.050 GA
85XU0407S04	4X1/4 U DRIVE PIN STAINLESS	2.000 EA
LB1119N	WARNING LABEL	1.000 EA
LC0005	CONN.DIA.,TY M,9-LD,DUAL VOLT,REVERSING	1.000 EA
NP1259L	ALUM SUPER-E UL CSA-EEV CC NEMA PREMIUM	1.000 EA
09PA1000	PACKAGING GROUP COMBINED PRINT	1.000 EA
LB1350	BAR CODE LABEL FOR YORK	1.000 EA
MN416A01	TAG-INSTAL-MAINT no wire (2100/bx) 4/22	1.000 EA
LD7020D09	LEAD SET, 12AWG, 9 LEAD, 20" LONG LEADS	1.000 EA

AC Induction Motor Performance Data

Record # 47544

Typical performance - not guaranteed values

Winding: 09WGT118-R001		Type: 0954M		Enclosure: TEFC	
Nameplate Data			460 V, 60 Hz: High Voltage Connection		
Rated Output (HP)	7.5	Full Load Torque	33.2 LB-FT		
Volts	230/460	Start Configuration	direct on line		
Full Load Amps	22/11	Breakdown Torque	113 LB-FT		
R.P.M.	1180	Pull-up Torque	41.3 LB-FT		
Hz	60 Phase	3	Locked-rotor Torque	57.4 LB-FT	
NEMA Design Code	A KVA Code	J	Starting Current	74.8 A	
Service Factor (S.F.)	1.15	No-load Current	6.06 A		
NEMA Nom. Eff.	91 Power Factor	70	Line-line Res. @ 25°C	0.87037 Ω	
Rating - Duty	40C AMB-CONT		Temp. Rise @ Rated Load	36°C	
S.F. Amps			Temp. Rise @ S.F. Load	42°C	
			Locked-rotor Power Factor	25.8	

Load Characteristics 460 V, 60 Hz, 7.5 HP

% of Rated Load	25	50	75	100	125	150	S.F.
Power Factor	32	52	63	70	74	75	72
Efficiency	83.2	89.4	90.9	91.1	90.7	89.9	90.9
Speed	1196.5	1192.4	1188.3	1183.7	1178.7	1173.2	1181
Line amperes	6.49	7.59	9.09	11	13.1	15.5	12.3

Performance Graph at 460V, 60Hz, 7.5HP Typical performance - Not guaranteed values

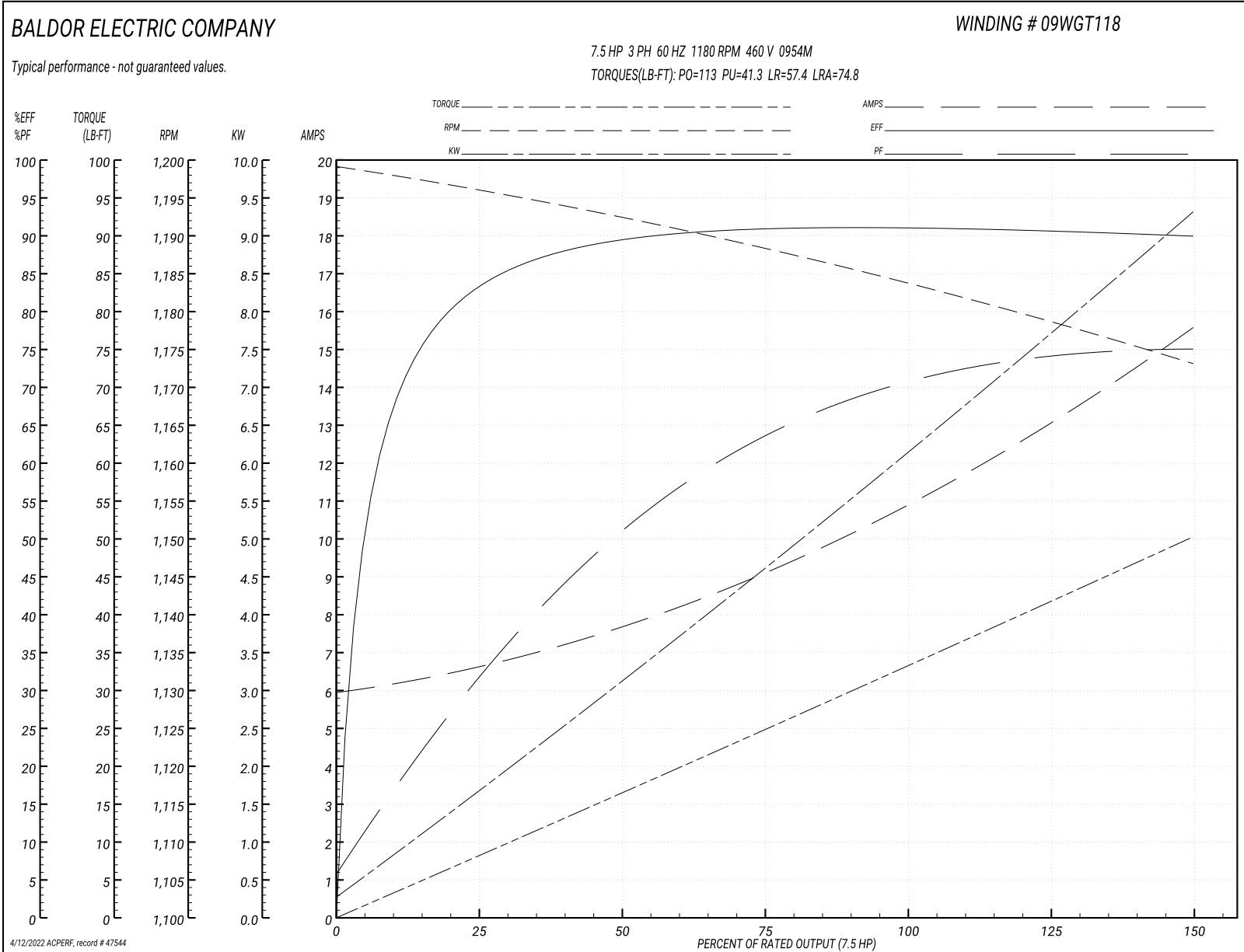

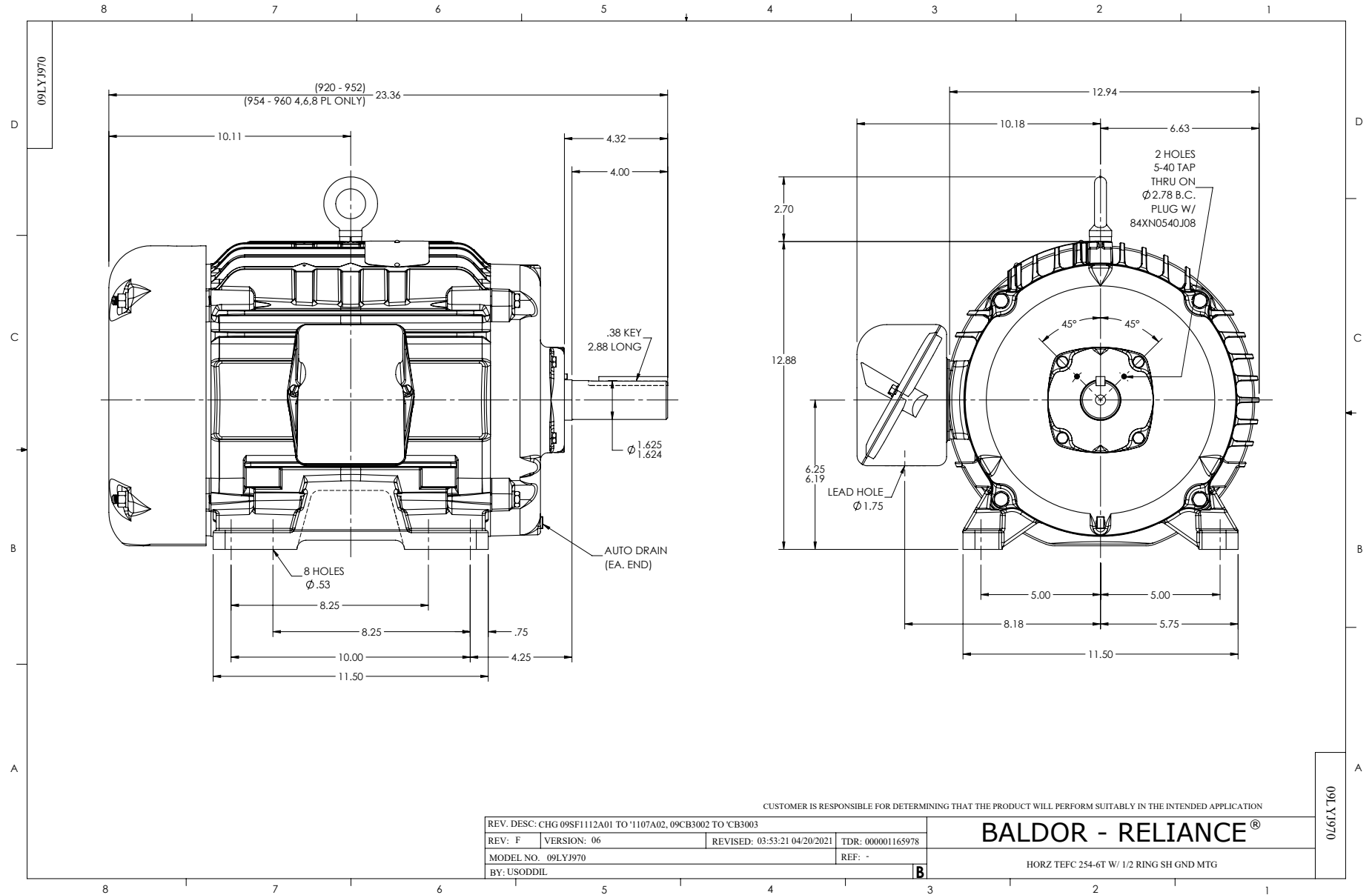

CD0005

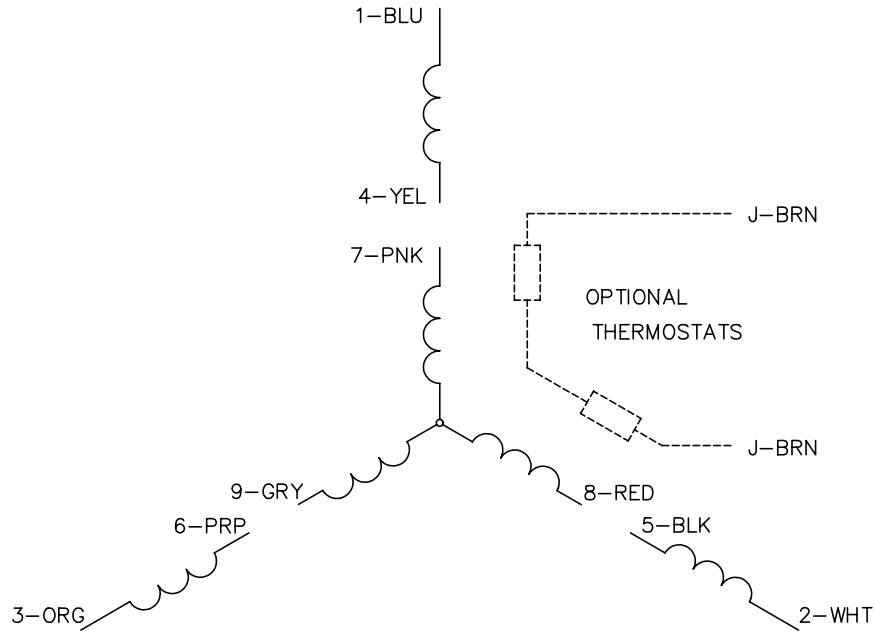

LOW VOLTAGE
(2Y)

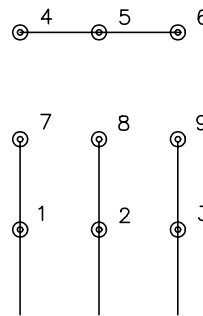

LINE

HIGH VOLTAGE
(1Y)

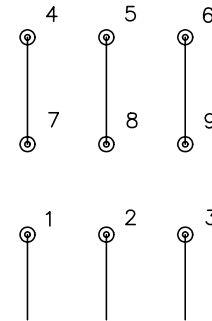

LINE

NOTES:

1. INTERCHANGE ANY TWO LINE LEADS TO REVERSE ROTATION.
2. OPTIONAL THERMOSTATS ARE PROVIDED WHEN SPECIFIED.
3. ACTUAL NUMBER OF INTERNAL PARALLEL CIRCUITS MAY BE A MULTIPLE OF THOSE SHOWN ABOVE.
4. LEAD COLORS ARE OPTIONAL. LEADS MUST ALWAYS BE NUMBERED AS SHOWN.

REV. DESC: REVISE TO SHOW OPTIONAL COLORS

REV. LTR: E BY: JLP

REVISED: 01/19/99 10:15

TDR: 0171435

90000

FILE: AAA00005140

MDL: -

MTL: -

BALDOR ELECTRIC Co.

3PH, DV, 9 LEADS

CD0005

Marketing maintained PDF of MN416:

<http://www.baldor.com/support/Literature/Load.ashx/MN416?ManNumber=MN416>