

**BALDOR® • RELIANCE** 

**Product Information Packet**

**EJMM4104T-G**

**56M 4P TEFC HOR 286JM SE**

Part Detail							
Revision:	D	Status:	PRD/A	Change #:		Proprietary:	No
Type:	AC	Elec. Spec:	10WGY538	CD Diagram:	CD0180	Mfg Plant:	
Mech. Spec:	10H520	Layout:	10LYH520	Poles:	04	Created Date:	04-02-2019
Base:	RG	Eff. Date:	02-18-2022	Leads:	9#8		

Specs			
Catalog Number:	EJMM4104T-G	Insulation Class:	F
Enclosure:	TEFC	Inverter Code:	Inverter Ready
Frame:	286JM	IP Rating:	NONE
Frame Material:	Iron	KVA Code:	J
Output @ Frequency:	30.000 HP @ 60 HZ	Lifting Lugs:	Standard Lifting Lugs
Synchronous Speed @ Frequency:	1800 RPM @ 60 HZ	Locked Bearing Indicator:	Locked Bearing
Voltage @ Frequency:	460.0 V @ 60 HZ	Motor Lead Quantity/Wire Size:	9 @ 8 AWG
	230.0 V @ 60 HZ	Motor Lead Termination:	Flying Leads
XP Class and Group:	None	Motor Type:	1056M
XP Division:	Not Applicable	Mounting Arrangement:	F1
Agency Approvals:	UR	Power Factor:	80
	CSA EEV	Product Family:	General Purpose
	CSA	Pulley End Bearing Type:	Ball
Auxillary Box:	No Auxillary Box	Pulley Face Code:	C-Face
Auxillary Box Lead Termination:	None	Pulley Shaft Indicator:	Tapped & Key
Base Indicator:	Rigid	Rodent Screen:	None
Bearing Grease Type:	Polyrex EM (-20F +300F)	RoHS Status:	ROHS NON-COMPLIANT
Blower:	None	Shaft Ground Indicator:	Shaft Grounding

<b>Current @ Voltage:</b>	38.000 A @ 460.0 V	<b>Shaft Rotation:</b>	Reversible
	76.000 A @ 230.0 V	<b>Shaft Slinger Indicator:</b>	Shaft Slinger
	78.000 A @ 208.0 V	<b>Speed Code:</b>	Single Speed
<b>Design Code:</b>	A	<b>Motor Standards:</b>	NEMA
<b>Drip Cover:</b>	No Drip Cover	<b>Starting Method:</b>	Direct on line
<b>Duty Rating:</b>	CONT	<b>Thermal Device - Bearing:</b>	None
<b>Electrically Isolated Bearing:</b>	Not Electrically Isolated	<b>Thermal Device - Winding:</b>	None
<b>Feedback Device:</b>	NO FEEDBACK	<b>Vibration Sensor Indicator:</b>	No Vibration Sensor
<b>Front Shaft Indicator:</b>	None	<b>Winding Thermal 1:</b>	None
<b>Heater Indicator:</b>	No Heater	<b>Winding Thermal 2:</b>	None

<b>Nameplate NP3443LUA</b>										
CAT.NO.	EJMM4104T-G				CUST. P/N				ENCL	TEFC
SPEC.	10H520Y538G2		CC	010A	FRAME	286JM		SER.NO.		
HP	30		CLASS	F	HZ	60				
R.P.M.	1760		PH.	3	DES.	A				
VOLTS	230/460			CODE	J	ODE BRG	6309	DE BRG	6312	
AMPS	76/38			USABLE AT 208V	78					
RATING	40C AMB-CONT			NEMA NOM. EFF.	93.6		GREASE	POLYREX EM		
P.F.	80	SER.F.	1.15		CT6-60H(10:1)VT3-60H(20:1)					
USABLE AT	50HZ 30HP 190/380V 88/44A				SF1.0					
VOLTS		AMPS		MAX. SPACE HEATER TEMP.						

Parts List		
Part Number	Description	Quantity
SA368039	SA 10H520Y538G2	1.000 EA
RA357528	RA 10H520Y538G2	1.000 EA
10CB3000SP	KOBX, CAST W/2.00 LEAD HOLE	1.000 EA
09GS1000SP	GASKET-CONDUIT BOX, 1/16 THICK LEXIDE	1.000 EA
10XN3118K12	5/16-18 X .75 GRADE 5, ZINC PLATED	4.000 EA
HW1001A31	LOCKWASHER 5/16, ZINC PLT.591 OD, .319 I	4.000 EA
WD1000B25	GND LUG, BURNDY L125HP OR T&B L125HP-BB	1.000 EA
19XW3118G08	.31-18X.50,HEX WSHR HD,TAPTITE 2,GREEN	1.000 EA
10EP1106A01	FR ENDPLATE, MACH	1.000 EA
HA4017A01	1/8 X 4 GREASE EXT (F/S)	1.000 EA
10XN3816K32	BOLT, 3/8-16X2 HH YZ(5)	4.000 EA
HW1001A38	LOCKWASHER 3/8, ZINC PLT .688 OD, .382 I	4.000 EA
HW5100A11	W3917-042 WVY WSHR (WB)	1.000 EA
10XN2520K32	1/4-20 X 2.00 HX HD SCRW GRADE 5, ZINC P	2.000 EA
HW1001A25	LOCKWASHER 1/4, ZINC PLT .493 OD, .255 I	2.000 EA
10EP1304A01	PU ENDPLATE, MACH	1.000 EA
10XN3816K28	3/8-16 X 1.75 HEX HD CAP SCREW, GRADE 5	4.000 EA
HW1001A38	LOCKWASHER 3/8, ZINC PLT .688 OD, .382 I	4.000 EA
10XN3118K40	5/16-18 X 2.75" HEX HD, GRADE 5	4.000 EA
HW1001A31	LOCKWASHER 5/16, ZINC PLT.591 OD, .319 I	4.000 EA
10FH4000	310 FAN HOUSING STAMPED	1.000 EA
51XF2520A08	SCREW, HEX SER SLT HD, ZN 1/4-20 X .50 L	4.000 EA
HW4600B41	V-RING SLINGER 2.125 X 2.880 X 0.280	1.000 EA
10CB3500SP	CONDUIT BOX LID, CAST	1.000 EA

Parts List (continued)		
Part Number	Description	Quantity
10GS1000SP	GASKET, CONDUIT BOX LID	1.000 EA
51XW2520A12	.25-20 X .75, TAPTITE II, HEX WSHR SLTD	4.000 EA
HW2501E21	KEY, 1/4 SQ X 2.375	1.000 EA
LB1115N	LABEL,LIFTING DEVICE (ON ROLLS)	1.000 EA
HW4500A21	1618BALEMITE FITTING 825 UNIVERSAL	1.000 EA
HA4001A01SP	DRAIN PLUG, PLASTIC (MICRO PLAS)	1.000 EA
HW4500A17	317400 ALEMITE GREASE RELIEF	1.000 EA
HA4051A00	PLASTIC CAP FOR GREASE FITTING	1.000 EA
MJ1000A02	GREASE, MOBIL POLYREX EM - 124047	0.130 LB
HW4500A03	GREASE FITTING, .125 NPT 1610(ALEMITE) 8	1.000 EA
HW4500A17	317400 ALEMITE GREASE RELIEF	1.000 EA
HA4051A00	PLASTIC CAP FOR GREASE FITTING	1.000 EA
HA4001A01SP	DRAIN PLUG, PLASTIC (MICRO PLAS)	1.000 EA
09FN3001C02	EXTERNAL FAN, PLASTIC (COMES W/SCREW FRO	1.000 EA
HW2500A25	WOODRUFF KEY USA #1008 #BLOW CARBON STEE	1.000 EA
MG1000Y03	MUNSELL 2.53Y 6.70/ 4.60, GLOSS 20,	0.070 GA
85XU0407S04	4X1/4 U DRIVE PIN STAINLESS	4.000 EA
LB1119N	WARNING LABEL	1.000 EA
LC0181	CONNECTION LABEL	1.000 EA
NP3443LUA	SS SUPER-E UL CSA-EEV PREM CC	1.000 EA
10PA1000	PACKAGING GROUP COMBINED PRINT PK1023A06	1.000 EA
MN416A01	TAG-INSTAL-MAINT no wire (2100/bx) 4/22	1.000 EA
FE-0000022	ZRTG FE ASSEMBLY	1.000 EA

**AC Induction Motor Performance Data**

Record # 32189

Typical performance - not guaranteed values

Winding: 10WGY538-R004		Type: 1056M	Enclosure: TEFC	
<b>Nameplate Data</b>			<b>460 V, 60 Hz: High Voltage Connection</b>	
Rated Output (HP)	30	Full Load Torque	88.7 LB-FT	
Volts	230/460	Start Configuration	direct on line	
Full Load Amps	76/38	Breakdown Torque	330 LB-FT	
R.P.M.	1760	Pull-up Torque	142 LB-FT	
Hz	60 Phase	Locked-rotor Torque	178 LB-FT	
NEMA Design Code	A KVA Code	Starting Current	270 A	
Service Factor (S.F.)	1.15	No-load Current	17.9 A	
NEMA Nom. Eff.	93.6 Power Factor	Line-line Res. @ 25°C	0.19377 Ω	
Rating - Duty	40C AMB-CONT	Temp. Rise @ Rated Load	64°C	
S.F. Amps		Temp. Rise @ S.F. Load	76°C	
		Locked-rotor Power Factor	30.9	
		Rotor inertia	4.47 LB-FT <sup>2</sup>	

**Load Characteristics 460 V, 60 Hz, 30 HP**

% of Rated Load	25	50	75	100	125	150	S.F.
Power Factor	41	63	73	80	82	85	81
Efficiency	87.6	92.3	93.5	93.7	93.4	92.9	93.5
Speed	1792.2	1787.6	1782.4	1776.5	1770.3	1762.1	1773
Line amperes	19.8	24.3	30.7	37.6	45.6	55.2	42.4

Performance Graph at 460V, 60Hz, 30.0HP Typical performance - Not guaranteed values

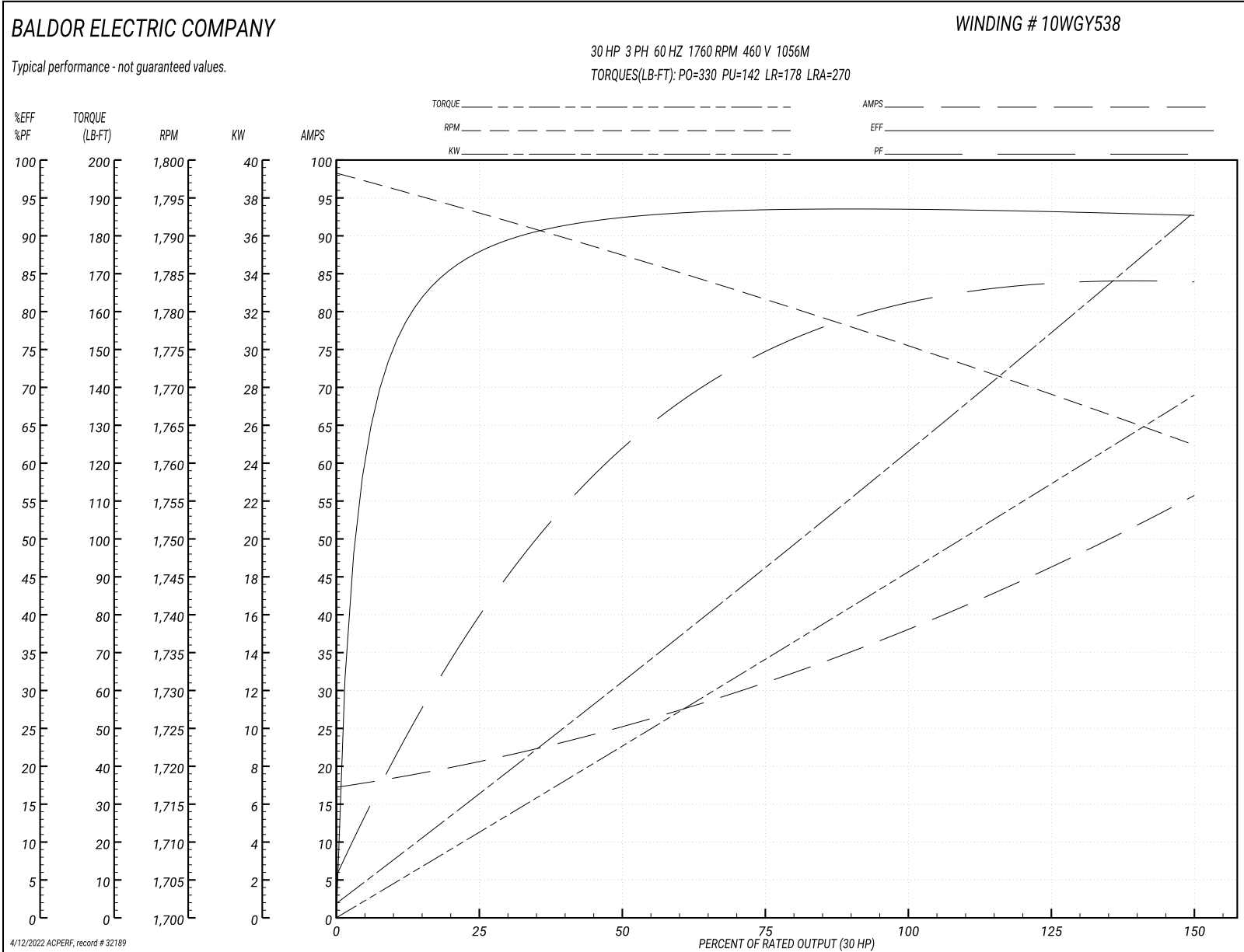



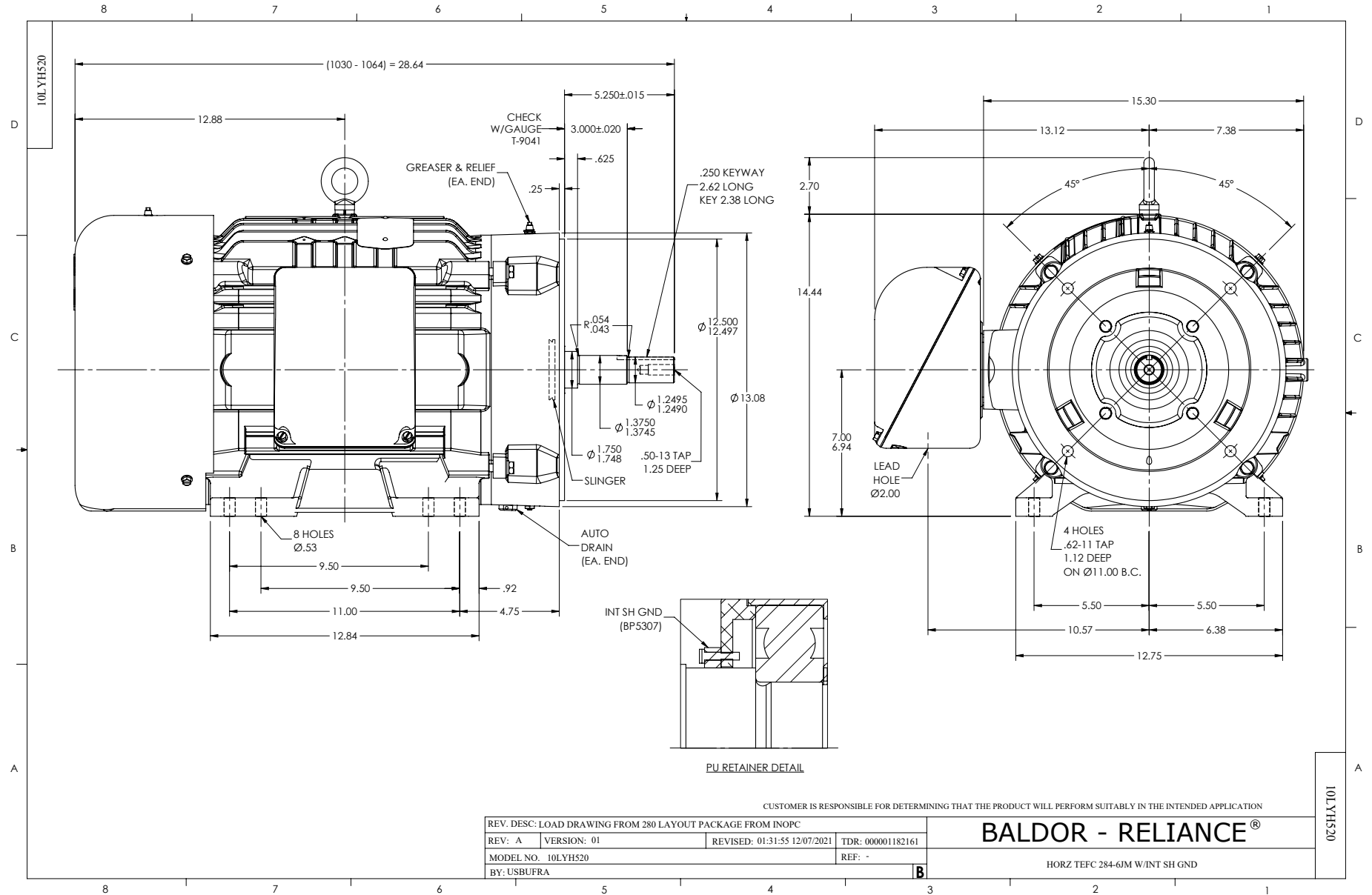

CD0180

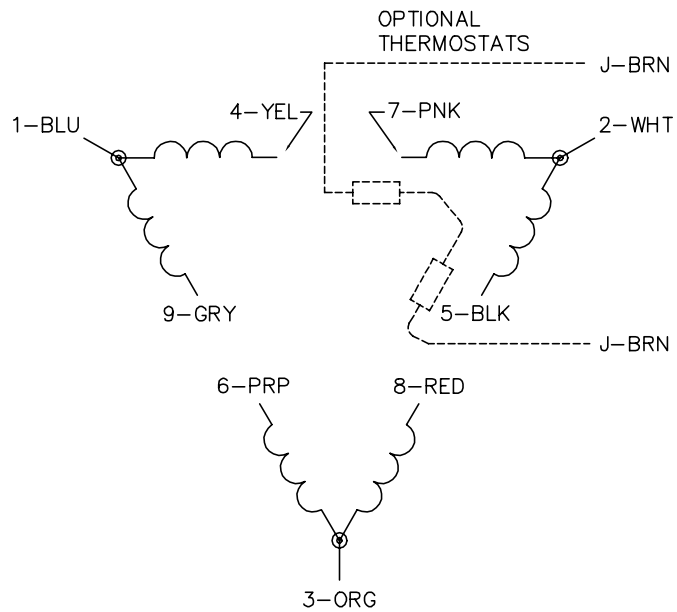

LOW VOLTAGE  
(2D)

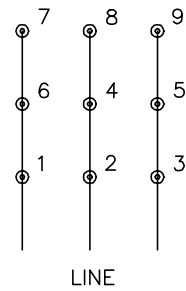

HIGH VOLTAGE  
(1D)



NOTES:

1. INTERCHANGE ANY TWO LINE LEADS TO REVERSE ROTATION.
2. OPTIONAL THERMOSTATS ARE PROVIDED WHEN SPECIFIED.
3. ACTUAL NUMBER OF INTERNAL PARALLEL CIRCUITS MAY BE A MULTIPLE OF THOSE SHOWN ABOVE.
4. LEAD COLORS ARE OPTIONAL. LEADS MUST ALWAYS BE NUMBERED AS SHOWN.

CD0180

REV. DESC: ADD CLASS CONN00000007		
REV. LTR: D	VERSION: 01	TDR: 000001099922
FILE: \AAA\00005\148	REVISED: 10:25:29 02/19/2019	BY: ENBRIRO
MTL: -	© □	

**BALDOR - RELIANCE®**

3PH, DV, 9 LEADS, DELTA CONNECTION

SH 1 of 1

Marketing maintained PDF of MN416:

<http://www.baldor.com/support/Literature/Load.ashx/MN416?ManNumber=MN416>