

BALDOR® • RELIANCE 

Product Information Packet

EJPM2551T

75HP, 1775RPM, 3PH, 60HZ, 365JP, 4462M, OPSB, F

Part Detail							
Revision:	J	Status:	PRD/A	Change #:		Proprietary:	No
Type:	AC	Elec. Spec:	44WGW013	CD Diagram:	CD0180	Mfg Plant:	
Mech. Spec:	44F048	Layout:	44LYF048	Poles:	04	Created Date:	06-05-2015
Base:	RG	Eff. Date:	02-04-2019	Leads:	9#6		

Specs			
Catalog Number:	EJPM2551T	Inverter Code:	Inverter Ready
Enclosure:	OPSB	KVA Code:	F
Frame:	365JP	Lifting Lugs:	Standard Lifting Lugs
Frame Material:	Steel	Locked Bearing Indicator:	Locked Bearing
Output @ Frequency:	75.000 HP @ 60 HZ	Motor Lead Quantity/Wire Size:	9 @ 6 AWG
Synchronous Speed @ Frequency:	1800 RPM @ 60 HZ	Motor Lead Exit:	Ko Box
Voltage @ Frequency:	230.0 V @ 60 HZ	Motor Lead Termination:	Flying Leads
	460.0 V @ 60 HZ	Motor Type:	4462M
Agency Approvals:	CSA	Mounting Arrangement:	F1
	CSA EEV	Power Factor:	85
	UR	Product Family:	General Purpose
Auxillary Box:	No Auxillary Box	Pulley End Bearing Type:	Ball
Auxillary Box Lead Termination:	None	Pulley Face Code:	C-Face
Base Indicator:	Rigid	Pulley Shaft Indicator:	Tapped & Key
Bearing Grease Type:	Polyrex EM (-20F +300F)	Rodent Screen:	Included
Blower:	None	Shaft Extension Location:	Pulley End
Current @ Voltage:	170.000 A @ 230.0 V	Shaft Ground Indicator:	No Shaft Grounding
	85.000 A @ 460.0 V	Shaft Rotation:	Reversible

Design Code:	B	Shaft Slinger Indicator:	No Slinger
Drip Cover:	No Drip Cover	Speed Code:	Single Speed
Duty Rating:	CONT	Motor Standards:	NEMA
Electrically Isolated Bearing:	Not Electrically Isolated	Starting Method:	Direct on line
Feedback Device:	NO FEEDBACK	Thermal Device - Bearing:	None
Front Face Code:	Standard	Thermal Device - Winding:	None
Front Shaft Indicator:	None	Vibration Sensor Indicator:	No Vibration Sensor
Heater Indicator:	No Heater	Winding Thermal 1:	None
Insulation Class:	F	Winding Thermal 2:	None

Nameplate NP2138LUA											
CAT.NO.	EJPM2551T			P/N				ENCLOSURE	OPSB		
SPEC.	44F048W013G3		CC	010A		FRAME	365JP		S/N		
HP	75			CLASS	F		HZ	60			
RPM	1775			PH	3		DES	B			
VOLT	230/460			KVA-CODE	F		ODE BRG	6312		DE BRG	6313
AMP	170/85			USABLE AT	208V						
RATING	40C AMB-CONT			GREASE	POLYREX EM						
NEMA-NOM-EFF	95	PF	85	SER.F.	1.15						
HTR-VOLTS	50HZ 75HP 190/380V 204/102A					SF1.0					
HTR-AMPS											

Parts List		
Part Number	Description	Quantity
SA302192	SA 44F048W013G3	1.000 EA
RA289278	RA 44F048W013G3	1.000 EA
HA6731	LIFTING LUG FOR 44 FRAME MOTORS.	2.000 EA
HA6616A01	CAST ADAPTOR, 44 FRAME - NEMA 364-5 - MA	1.000 EA
19XW3816A12	.38-16 X .75 HEX WASHER HEAD TAPTITE II	2.000 EA
HW1001A38	LOCKWASHER 3/8, ZINC PLT .688 OD, .382 I	2.000 EA
10CB3002A02	CB 309 3.62 LD HOLE, .38 MTG HOLE & 3.50	1.000 EA
19XW3118A16	.31-18 HEX WASHER HEAD TAPTITE II 1.00 L	4.000 EA
HW1001A31	LOCKWASHER 5/16, ZINC PLT.591 OD, .319 I	4.000 EA
WD1000B25	GND LUG, BURNDY L125HP OR T&B L125HP-BB	1.000 EA
19XW3118G08	.31-18X.50,HEX WSHR HD,TAPTITE 2,GREEN	1.000 EA
44EP1203A03	FREP, MACH 312 BRG W/SCRN	1.000 EA
HA1201	RODENT SCREEN FOR 44 OPSB & 44EP1203	1.000 EA
51XW1032A06	10-32 X .38, TAPTITE II, HEX WSHR SLTD S	4.000 EA
HW5100A15	W4997-050 WVY WSHR (WB)	1.000 EA
10XN3816K48	3/8-16 X 3 HEX HD CAP SCREW,Z/P	4.000 EA
HW1001A38	LOCKWASHER 3/8, ZINC PLT .688 OD, .382 I	4.000 EA
44EP1403A05	E.P. MACH, 364-5TC FOR 313 BRG W/SCREEN	1.000 EA
HA1201	RODENT SCREEN FOR 44 OPSB & 44EP1203	1.000 EA
51XW1032A06	10-32 X .38, TAPTITE II, HEX WSHR SLTD S	4.000 EA
XY5013A12	NUT,1/2-13,HEX,STEEL,ZINCPLATED	8.000 EA
10CB3500SP	CONDUIT BOX LID, CAST	1.000 EA
51XW2520A12	SCREW, HEX SER SLT HD, ZN, 1/4-20 X .75	4.000 EA
HW2501G18	SQUARE STEEL KEY .375 X 2.00 LONG	1.000 EA

Parts List (continued)		
Part Number	Description	Quantity
LB1115N	LABEL,LIFTING DEVICE (ON ROLLS)	1.000 EA
44AD2001A02	BAFFLE 44 OPEN,"X"=1.50, SLOTTED BAND MT	1.000 EA
HA4051A00	PLASTIC CAP FOR GREASE FITTING	1.000 EA
HW4500A03	GREASE FITTING, .125 NPT 1610(ALEMITE) 8	1.000 EA
HW4500A20	1/8NPT SL PIPE PLUG	1.000 EA
MJ1000A02	GREASE, MOBIL POLYREX EM - 124047	0.030 LB
44AD2001A02	BAFFLE 44 OPEN,"X"=1.50, SLOTTED BAND MT	1.000 EA
HA4051A00	PLASTIC CAP FOR GREASE FITTING	1.000 EA
HW4500A03	GREASE FITTING, .125 NPT 1610(ALEMITE) 8	1.000 EA
HW4500A20	1/8NPT SL PIPE PLUG	1.000 EA
MG1000Y03	MUNSELL 2.53Y 6.70/ 4.60, GLOSS 20,	0.080 GA
85XU0407S04	4X1/4 U DRIVE PIN STAINLESS	4.000 EA
HA3175A02	THRUBOLT STUD 1/2-13 X 24.500 - GRADE 2	4.000 EA
LB1119N	WARNING LABEL	1.000 EA
LC0181	CONNECTION LABEL	1.000 EA
NP2138LUA	ALUM SUPER-E UL CSA-EEV PREM CC (300SER)	1.000 EA
44PA1000	PK GP COMB PRINT 39-3/8X31X23-7/8	1.000 EA
MN416A01	TAG-INSTAL-MAINT no wire (2100/bx) 4/22	1.000 EA

AC Induction Motor Performance Data

Record # 31660

Typical performance - not guaranteed values

Winding: 44WGW013-R002			Type: 4462M			Enclosure: OPEN		
Nameplate Data				460 V, 60 Hz: High Voltage Connection				
Rated Output (HP)	75		Full Load Torque	222 LB-FT				
Volts	230/460		Start Configuration	direct on line				
Full Load Amps	170/85		Breakdown Torque	610 LB-FT				
R.P.M.	1775		Pull-up Torque	235 LB-FT				
Hz	60	Phase	3	Locked-rotor Torque	327 LB-FT			
NEMA Design Code	B		KVA Code	F				
Service Factor (S.F.)	1.15		Starting Current	507 A				
NEMA Nom. Eff.	95	Power Factor	85	No-load Current	26.2 A			
Rating - Duty	40C		Temp. Rise @ Rated Load	30°C				
S.F. Amps	AMB-CONT		Temp. Rise @ S.F. Load	37°C				
				Locked-rotor Power Factor	26.3			
				Rotor inertia	11.7 LB-FT ²			

Load Characteristics 460 V, 60 Hz, 75 HP

% of Rated Load	25	50	75	100	125	150	S.F.
Power Factor	56	77	84	86	87	87	86
Efficiency	93.6	95.6	95.4	95.3	94.6	93.9	94.7
Speed	1794	1788	1782	1776	1769	1761	1776
Line amperes	33.9	48	66.1	85.4	106	128	100

Performance Graph at 460V, 60Hz, 75.0HP Typical performance - Not guaranteed values

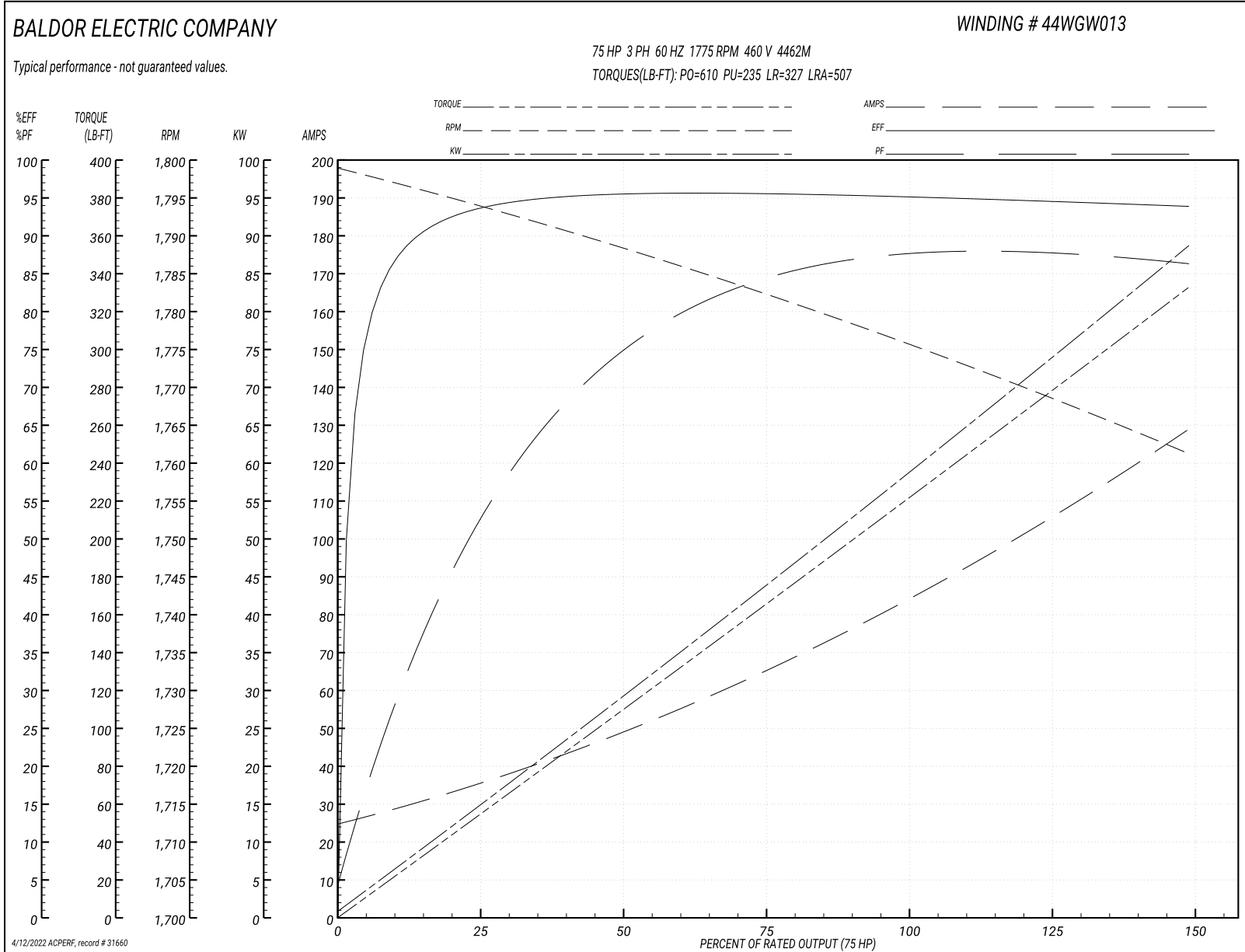

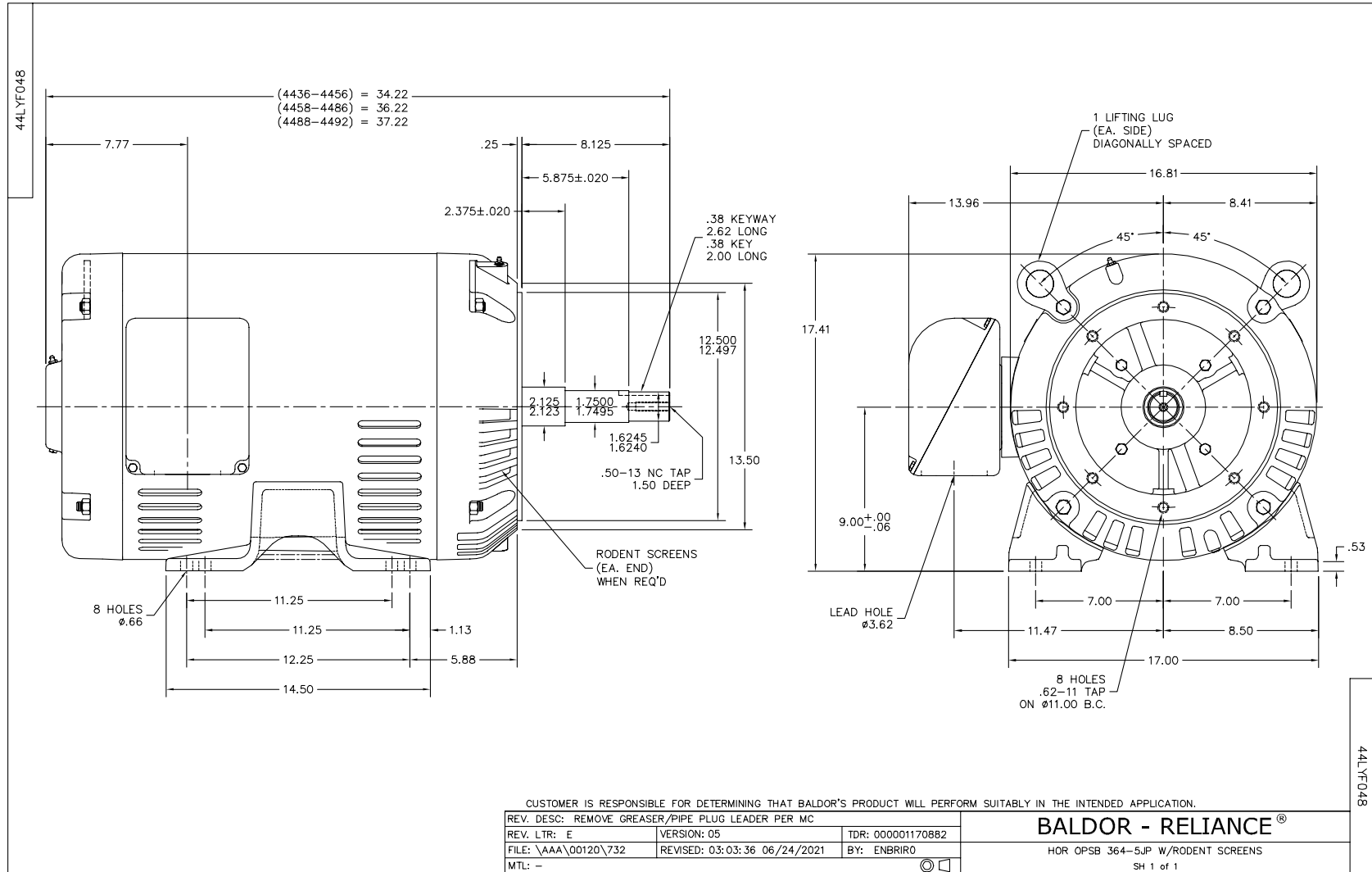

CD0180

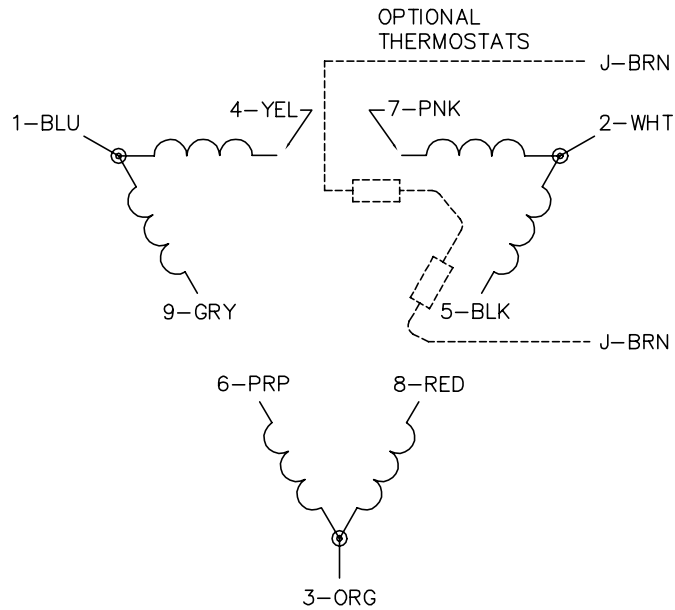

LOW VOLTAGE
(2D)

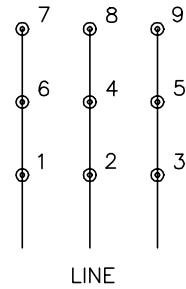

HIGH VOLTAGE
(1D)

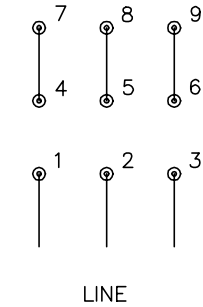

NOTES:

1. INTERCHANGE ANY TWO LINE LEADS TO REVERSE ROTATION.
2. OPTIONAL THERMOSTATS ARE PROVIDED WHEN SPECIFIED.
3. ACTUAL NUMBER OF INTERNAL PARALLEL CIRCUITS MAY BE A MULTIPLE OF THOSE SHOWN ABOVE.
4. LEAD COLORS ARE OPTIONAL. LEADS MUST ALWAYS BE NUMBERED AS SHOWN.

CD0180

REV. DESC: ADD CLASS CONN00000007		
REV. LTR: D	VERSION: 01	TDR: 000001099922
FILE: \AAA\00005\148	REVISED: 10:25:29 02/19/2019	BY: ENBRIRO
MTL: -	© □	

BALDOR - RELIANCE®

3PH, DV, 9 LEADS, DELTA CONNECTION

SH 1 of 1

Marketing maintained PDF of MN416:

<http://www.baldor.com/support/Literature/Load.ashx/MN416?ManNumber=MN416>