

BALDOR® • RELIANCE 

Product Information Packet

EM2542T-8

50HP,3525RPM,3PH,60HZ,324TS,4058M,OPSB,F

Part Detail							
Revision:	G	Status:	PRD/A	Change #:		Proprietary:	No
Type:	AC	Elec. Spec:	40WGX311	CD Diagram:	CD0695	Mfg Plant:	
Mech. Spec:	40E213	Layout:	40LYE213	Poles:	02	Created Date:	08-12-2015
Base:	RG	Eff. Date:	11-14-2017	Leads:	6#6		

Specs			
Catalog Number:	EM2542T-8	IP Rating:	NONE
Enclosure:	OPSB	KVA Code:	G
Frame:	324TS	Lifting Lugs:	Standard Lifting Lugs
Frame Material:	Steel	Locked Bearing Indicator:	No Locked Bearing
Output @ Frequency:	50.000 HP @ 60 HZ	Motor Lead Quantity/Wire Size:	6 @ 6 AWG
Synchronous Speed @ Frequency:	3600 RPM @ 60 HZ	Motor Lead Exit:	Ko Box
Voltage @ Frequency:	200.0 V @ 60 HZ	Motor Lead Termination:	Flying Leads
Agency Approvals:	UR	Motor Type:	4058M
	CSA EEV	Mounting Arrangement:	F1
	CSA	Power Factor:	90
Auxillary Box:	No Auxillary Box	Product Family:	General Purpose
Auxillary Box Lead Termination:	None	Pulley End Bearing Type:	Ball
Base Indicator:	Rigid	Pulley Face Code:	Standard
Bearing Grease Type:	Polyrex EM (-20F +300F)	Pulley Shaft Indicator:	Standard
Blower:	None	Rodent Screen:	None
Current @ Voltage:	129.000 A @ 200.0 V	Shaft Extension Location:	Pulley End
Design Code:	A	Shaft Ground Indicator:	No Shaft Grounding
Drip Cover:	No Drip Cover	Shaft Rotation:	Reversible

Duty Rating:	CONT	Shaft Slinger Indicator:	No Slinger
Electrically Isolated Bearing:	Not Electrically Isolated	Speed Code:	Single Speed
Feedback Device:	NO FEEDBACK	Motor Standards:	NEMA
Front Face Code:	Standard	Starting Method:	Part Winding
Front Shaft Indicator:	None	Thermal Device - Bearing:	None
Heater Indicator:	No Heater	Thermal Device - Winding:	None
Insulation Class:	F	Vibration Sensor Indicator:	No Vibration Sensor
Inverter Code:	Inverter Ready	Winding Thermal 1:	None
		Winding Thermal 2:	None

Nameplate NP3554L											
CAT.NO.	EM2542T-8			P/N				ENCL	OPSB		
SPEC.	40E213X311		CC	010A		FRAME	324TS		SER.NO.		
HP	50		CLASS	F		HZ	60				
RPM	3525		PH	3		DES	A				
VOLTS	200		CODE	G		ODE BRG	6309		DE BRG	6312	
AMPS	129		USABLE AT 208V								
RATING	40C AMB-CONT		NEMA-NOM-EFF	93		GREASE	POLYREX EM				
PF	90		SER.F.	1.15		VPWM INVERTER READY					
HTR-VOLTS			HTR-AMPS			MAX. SPACE HEATER TEMP.					

Parts List		
Part Number	Description	Quantity
SA305478	SA 40E213X311	1.000 EA
RA292699	RA 40E213X311	1.000 EA
HA6361A01	LIFTING LUG FOR 37, 39 & 40 FRAME ZINC	2.000 EA
HA6017	CAST ADAPTER, 40,42 KOBX	1.000 EA
19XW3118A12	.31-18 X .75 HEX WASHER HEAD TAPTITE II	2.000 EA
HW1001A31	LOCKWASHER 5/16, ZINC PLT.591 OD, .319 I	2.000 EA
WD1000B25	GND LUG, BURNDY L125HP OR T&B L125HP-BB	1.000 EA
19XW3118G08	.31-18X.50,HEX WSHR HD,TAPTITE 2,GREEN	1.000 EA
10CB3001	CONDUIT BOX CAST W/2.500 LEAD HOLE	1.000 EA
19XW3118A12	.31-18 X .75 HEX WASHER HEAD TAPTITE II	4.000 EA
HW1001A31	LOCKWASHER 5/16, ZINC PLT.591 OD, .319 I	4.000 EA
40EP3200A02	STD FREP OPEN 309 BRG	1.000 EA
HW5100A11	W3917-042 WVY WSHR (WB)	1.000 EA
40EP3201A01	PU ENDPLATE, MACH - OPEN - FOR 312 BRG	1.000 EA
XY3816A12	3/8-16 FINISHED NUT	8.000 EA
10CB3500SP	CONDUIT BOX LID, CAST	1.000 EA
51XW2520A12	.25-20 X .75, TAPTITE II, HEX WSHR SLTD	4.000 EA
HW2501H18	KEY, 1/2 SQ X 2.000	1.000 EA
LB1115N	LABEL,LIFTING DEVICE (ON ROLLS)	1.000 EA
HW4500A03	GREASE FITTING, .125 NPT 1610(ALEMITE) 8	1.000 EA
HW4500A20	1/8NPT SL PIPE PLUG	1.000 EA
HA4051A00	PLASTIC CAP FOR GREASE FITTING	1.000 EA
MJ1000A02	GREASE, MOBIL POLYREX EM - 124047	0.050 LB
HW4500A03	GREASE FITTING, .125 NPT 1610(ALEMITE) 8	1.000 EA

Parts List (continued)		
Part Number	Description	Quantity
HW4500A20	1/8NPT SL PIPE PLUG	1.000 EA
HA4051A00	PLASTIC CAP FOR GREASE FITTING	1.000 EA
HA3159A08	THRUBOLT- .38-16 X 20.00 LONG STUD	4.000 EA
MG1000Y03	MUNSELL 2.53Y 6.70/ 4.60, GLOSS 20,	0.070 GA
85XU0407S04	4X1/4 U DRIVE PIN STAINLESS	4.000 EA
40AD2002B01	LEXAN BAFFLE 40 FR OPEN	1.000 EA
40AD2002B01	LEXAN BAFFLE 40 FR OPEN	1.000 EA
LB1119N	WARNING LABEL	1.000 EA
LC0695	CONNECTION LABEL	1.000 EA
NP3554L	SS SUPER-E UL CSA-EEV PREM CC	1.000 EA
40PA1000	PACKAGING GROUP	1.000 EA
MN416A01	TAG-INSTAL-MAINT no wire (2100/bx) 4/22	1.000 EA

AC Induction Motor Performance Data

Record # 52219

Typical performance - not guaranteed values

Winding: 40WGX311-R001		Type: 4058M		Enclosure: OPSB	
Nameplate Data			200 V, 60 Hz: Single Voltage Motor		
Rated Output (HP)	50	Full Load Torque	74.7 LB-FT		
Volts	200	Start Configuration	direct on line		
Full Load Amps	129	Breakdown Torque	174 LB-FT		
R.P.M.	3525	Pull-up Torque	119 LB-FT		
Hz	60 Phase	3	Locked-rotor Torque	139 LB-FT	
NEMA Design Code	A KVA Code	G	Starting Current	892 A	
Service Factor (S.F.)	1.15	No-load Current	34.3 A		
NEMA Nom. Eff.	93 Power Factor	90	Line-line Res. @ 25°C	0.0243 Ω	
Rating - Duty	40C AMB-CONT		Temp. Rise @ Rated Load	46°C	
S.F. Amps			Temp. Rise @ S.F. Load	57°C	
			Locked-rotor Power Factor	23	
			Rotor inertia	2.49 LB-FT ²	

Load Characteristics 200 V, 60 Hz, 50 HP

% of Rated Load	25	50	75	100	125	150	S.F.
Power Factor	63	82	88	90	90	90	90
Efficiency	92.5	94.5	94.2	93.4	92.2	90.5	92.7
Speed	3582	3566	3547	3529	3508	3479	3516
Line amperes	46.8	70	98.2	129	162	205	149

Performance Graph at 200V, 60Hz, 50.0HP Typical performance - Not guaranteed values

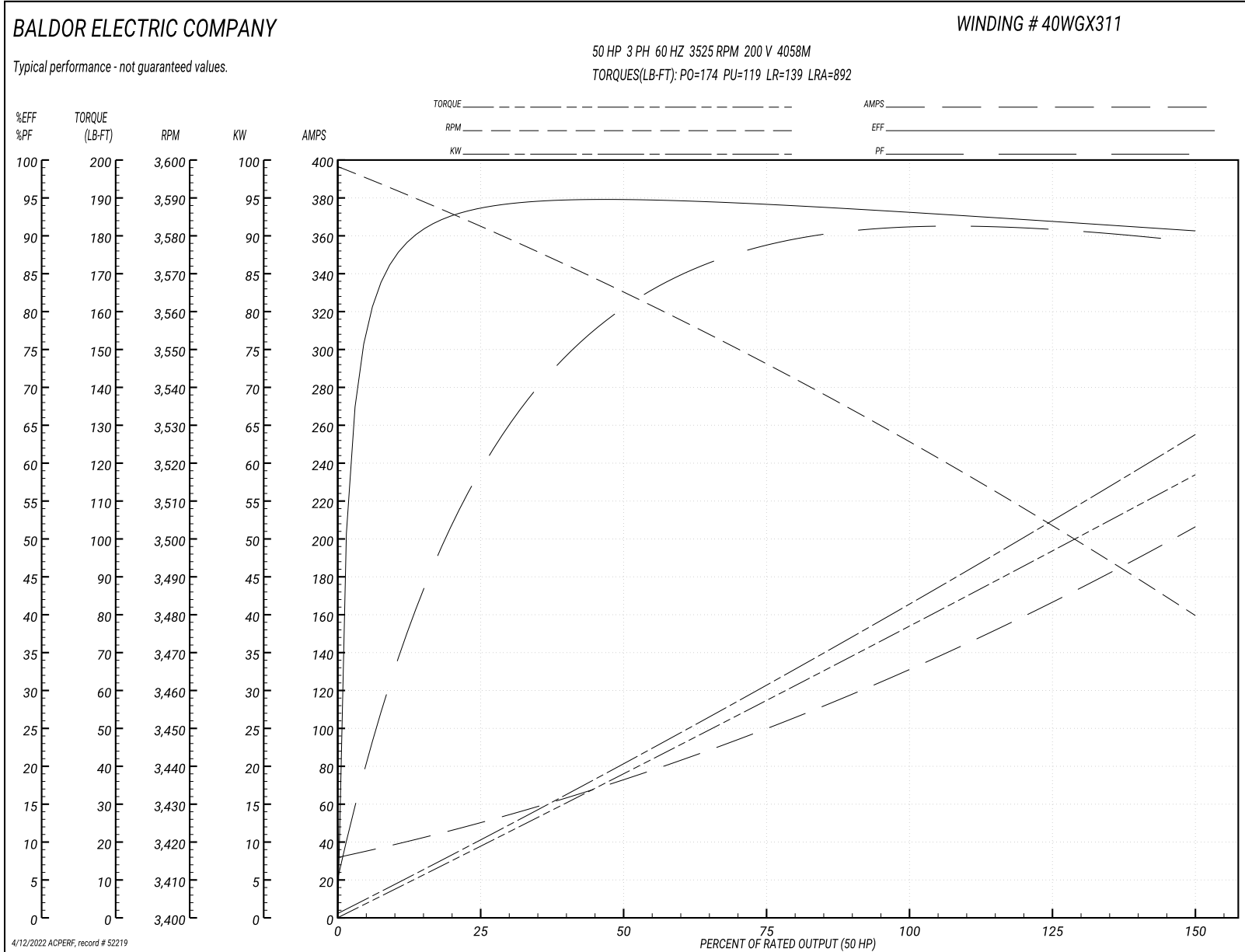

40LYE213

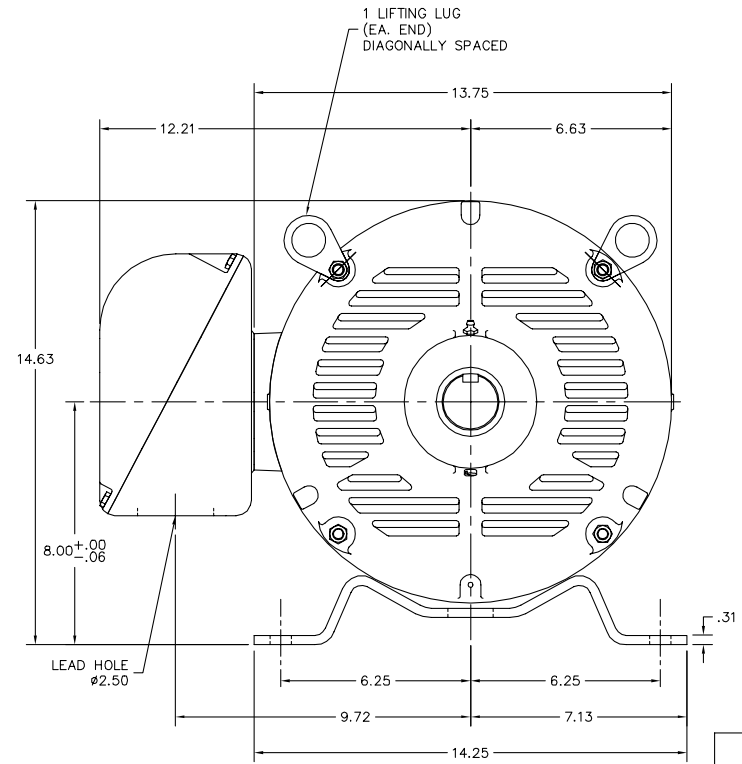
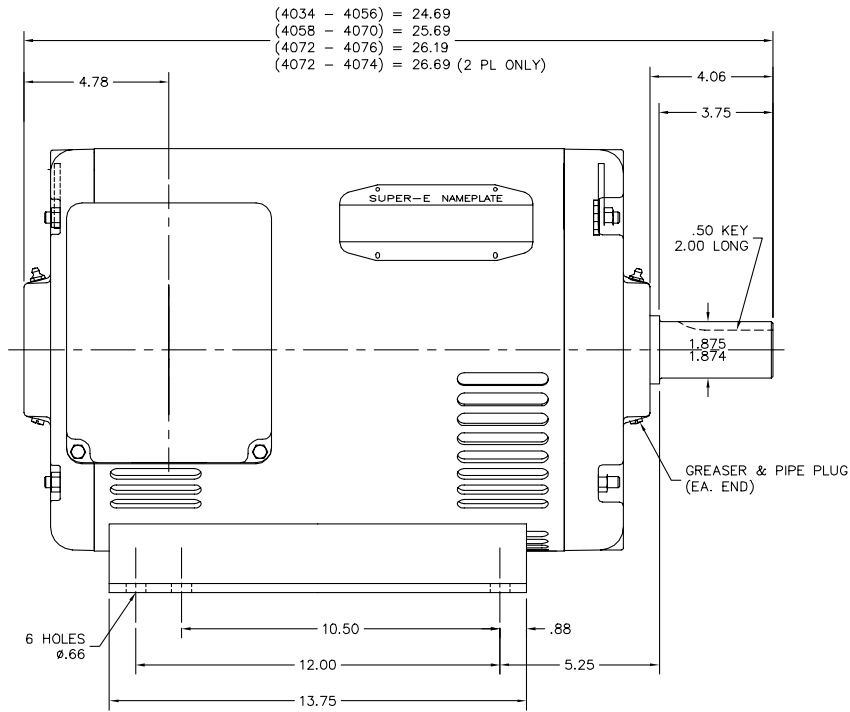

40LYE213

CUSTOMER IS RESPONSIBLE FOR DETERMINING THAT BALDOR'S PRODUCT WILL PERFORM SUITABLY IN THE INTENDED APPLICATION.

REV. DESC: UPDATED DESCRIPTION		
REV. LTR: C	VERSION: 03	TDR: 000000855149
FILE: \AAA\00163\890	REVISED: 12:35:28 05/23/2014	BY: ENNINDO
MTL: -		

BALDOR
 HORZ OPSB 324-6TS, SUPER-E
 SH 1 of 1

CD0695

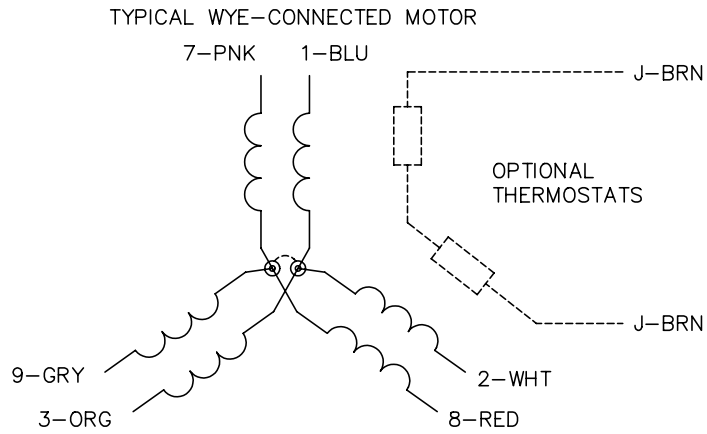

START CONNECTION

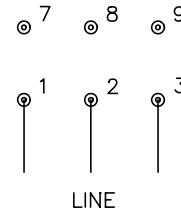

RUN CONNECTION

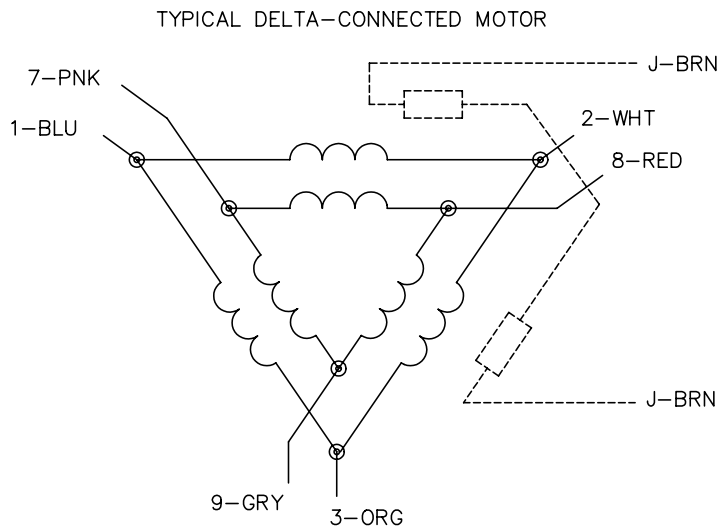
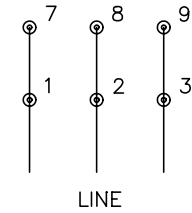

NOTES:

1. MOTOR MAY BE WYE CONNECTED OR DELTA CONNECTED.
2. INTERCHANGE ANY TWO LINE LEADS TO REVERSE ROTATION.
3. OPTIONAL THERMOSTATS ARE PROVIDED WHEN SPECIFIED.
4. ACTUAL NUMBER OF INTERNAL PARALLEL CIRCUITS MAY VARY.
5. LEAD COLORS ARE OPTIONAL. LEADS MUST ALWAYS BE NUMBERED AS SHOWN.

REV. DESC: REVISE TO SHOW OPTIONAL COLORS

REV. LTR: C BY: JLP

REVISED: 01/21/99 3:19

TDR: 0171435

9690D0

FILE: AAA00005151

MDL: -

MTL: -

BALDOR ELECTRIC Co.

3PH, SV, 6 LEADS, PART WINDING START

CD0695

Marketing maintained PDF of MN416:

<http://www.baldor.com/support/Literature/Load.ashx/MN416?ManNumber=MN416>