

DATE	APRIL 1, 2020	OUTLINE DIMENSIONS	MOTOR TYPE:
CATALOG NO.:	EP0/78		3-PHASE INDUCTION MOTOR
			FRAME NO. 145T

Pole	HP	kW	Hz	VOLT	r/min(rpm)
8	3/4	0.56	60	230/460	900

Ins	Rating	Dimension in	Approx Weight	Bearings
F	CONT.	Inch	57 lbs	DE:6205ZZ NDE:6205ZZ

Totally Enclosed Fan-Cooled Type. Squirrel-Cage Rotor.

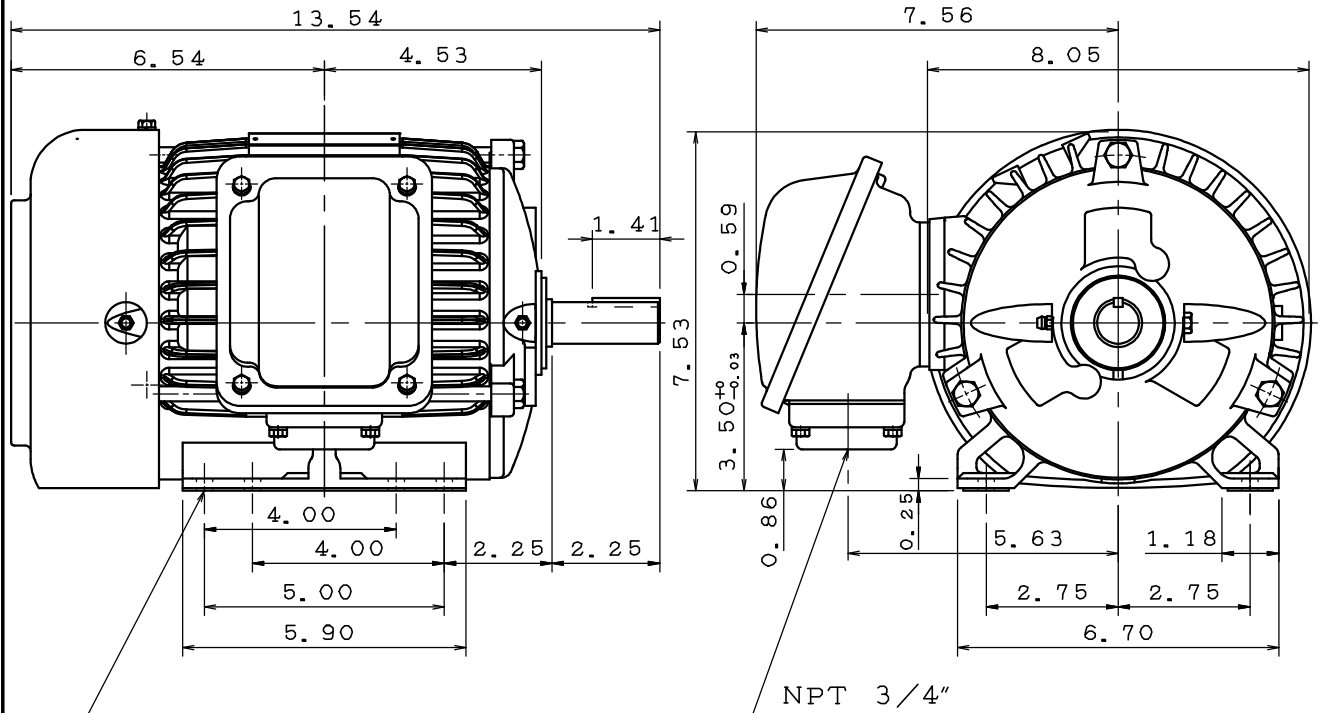

8- ϕ 0.34
Holes

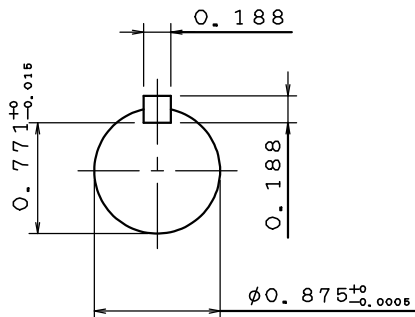

0		
---	--	--

DWG.	Mahato	07.25.19	TECO Westinghouse	DWG NO.
CHKD.	M. C. JENG	07.26.19		31049R340080
APPD.	M. C. JENG	07.26.19		

TECO Westinghouse

ISSUED March 6, 2019	PERFORMANCE DATA	ENCLOSURE TEFC
TYPE AEHH8N	3-PHASE INDUCTION MOTOR	CATALOG# EP0/78

NAMEPLATE INFORMATION

OUTPUT		POLE	FRAME SIZE	VOLTAGE	HZ	RATED AMBIENT	INS. CLASS	NEMA DESIGN	TIME RATING	SERVICE FACTOR
HP	KW									
0.75	0.6	8	145T	230/460	60	40°C	F	B	CONT.	1.15

TYPICAL PERFORMANCE

FULL LOAD RPM	EFFICIENCY				POWER FACTOR			MAXIMUM POWER FACTOR CORRECTION
	FULL LOAD		3/4 LOAD %	1/2 LOAD %	F. L. %	3/4 LOAD %	1/2 LOAD %	
	MIN. %	NOM. %						
855	70.0	72.8	70.0	64.0	53.0	44.0	34.0	1.1 KVAR

CURRENTS

NO LOAD			FULL LOAD			LOCKED ROTOR			NEMA KVA CODE LETTER
AT	AT	AT	AT	AT	AT	AT	AT	AT	
208 VOLT	230 VOLT	460 VOLT	208 VOLT	230 VOLT	460 VOLT	208 VOLT	230 VOLT	460 VOLT	
3.2	2.90	1.40	4.1	3.68	1.84	16.3	14.72	7.36	J

TORQUE

INERTIA

ACCEL TIME

FULL LOAD lb-ft	LOCKED ROTOR %FLT	PULL UP %FLT	BREAK DOWN %FLT	ROTOR WR ² lb-ft ²	NEMA LOAD WK ² lb-ft ²	MAX ALLOWABLE WK ² lb-ft ²	NEMA LOAD WK ² Sec	MAX ALLOWABLE WK ² Sec
4.605	185	175	240	0.117	23	120	8.55	36.51

SAFE STALL TIME IN SECONDS		ALLOWABLE STARTS PER HOUR		SOUND PRESSURE LEVEL @ 3 FT dB(A)
COLD	HOT	COLD	HOT	
92	46	2	1	

APPROVED:	K. Lo	DRAWING NO.	31057EP0/78	REVISION 0
-----------	--------------	-------------	--------------------	-------------------

DATE:
June 17, 2005

CONNECTION DIAGRAM

CATALOG NO.:
EP0/78

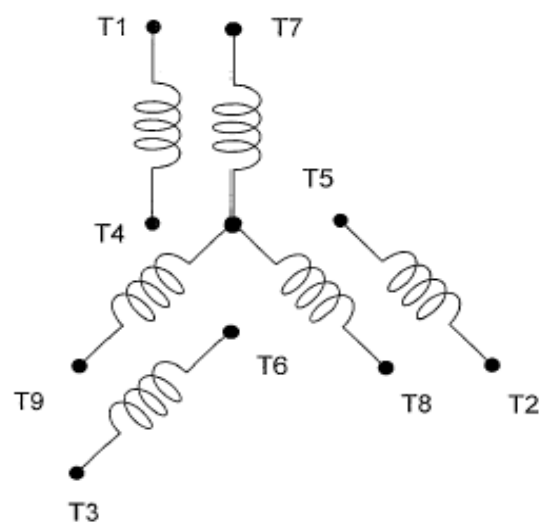

SCHEMATIC - 2Y/Y CONNECTION

ACROSS THE LINE CONNECTION

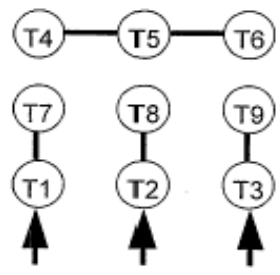

**LINE
230 VOLT CONNECTION**

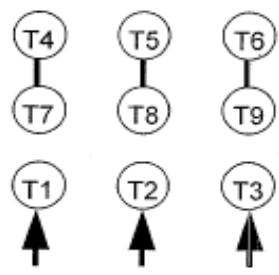

**LINE
460 VOLT CONNECTION**