

DATE	APRIL 1, 2020	OUTLINE DIMENSIONS	MOTOR TYPE:
CATALOG NO.:	EP0156		3-PHASE INDUCTION MOTOR
			FRAME NO. 284T

Pole	HP	kW	Hz	VOLT	r/min(rpm)
6	15	11	60	230/460	1200

Ins	Rating	Dimension in	Approx Weight	Bearings
F	CONT.	inch	① 398 lbs	DE:6311ZZ NDE:6310ZZ

Totally Enclosed Fan Cooled Type. Squirrel-cage Rotor.

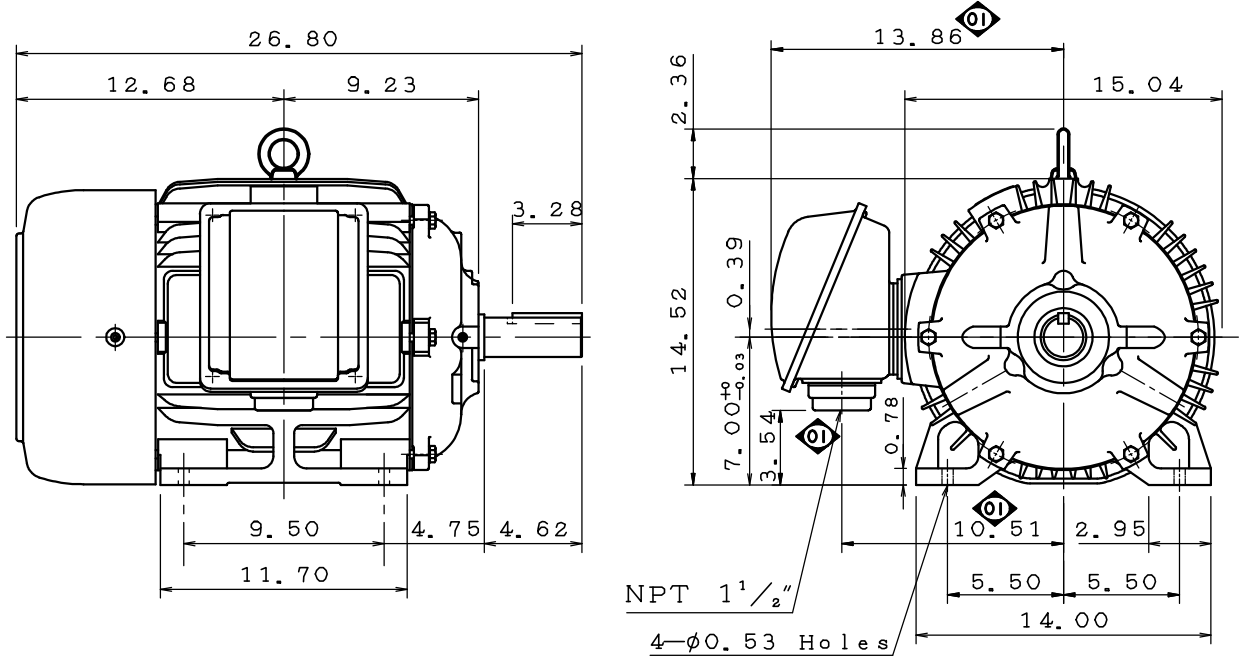

① 12.10.19 Enlarge T-BOX volume. J.F.Chen

DWG.	H. C. Yang	07.15.19	<b>TECO</b> <b>Westinghouse</b>	DWG NO.
CHKD.	M. C. JENG	07.26.19		31057M091061
APPD.	M. C. JENG	07.26.19		

# TECO Westinghouse

ISSUED <b>8/15/2014</b>	<b>PERFORMANCE DATA</b> <b>3-PHASE INDUCTION MOTOR</b>	ENCLOSURE <b>TEFC</b>
TYPE <b>AEHH8N</b>		CATALOG# <b>EP0156</b>

### NAMEPLATE INFORMATION

OUTPUT		POLE	FRAME SIZE	VOLTAGE	HZ	RATED AMBIENT	INS. CLASS	NEMA DESIGN	TIME RATING	SERVICE FACTOR
HP	KW									
<b>15</b>	<b>11.2</b>	<b>6</b>	<b>284T</b>	<b>230/460</b>	<b>60</b>	<b>40°C</b>	<b>F</b>	<b>B</b>	<b>CONT.</b>	<b>1.15</b>

### VARIABLE FREQUENCY DRIVE SERVICE

VARIABLE TORQUE				OHMS/PHASE EQUIVALENT WYE CIRCUIT (AT RATED OPERATING TEMPERATURE 25°C)				
HZ	HP	RPM	TORQUE (lb-ft)	R1	R2	X1	X2	X <sub>m</sub>
<b>3~60</b>	<b>0.0019~15</b>	<b>60~1200</b>	<b>0.166~67.03</b>	<b>0.2865</b>	<b>0.3834</b>	<b>1.2081</b>	<b>2.3238</b>	<b>39.197</b>

CONSTANT TORQUE				CONSTANT HORSEPOWER			
HZ	HP	RPM	TORQUE (lb-ft)	HZ	HP	RPM	TORQUE (lb-ft)
<b>6~60</b>	<b>1.5~15</b>	<b>120~1200</b>	<b>67.03</b>	<b>60~90</b>	<b>15</b>	<b>1200~1800</b>	<b>67.03~44.69</b>

### TYPICAL PERFORMANCE

FULL LOAD RPM	EFFICIENCY				POWER FACTOR			SOUND PRESSURE LEVEL @ 3 FT Db(A)
	FULL LOAD		3/4 LOAD %	1/2 LOAD %	FULL LOAD %	3/4 LOAD %	1/2 LOAD %	
	MIN.%	NOM.%						
<b>1175</b>	<b>91</b>	<b>92.4</b>	<b>93</b>	<b>93</b>	<b>83.5</b>	<b>79.5</b>	<b>70.5</b>	<b>64</b>

CURRENTS									NEMA KVA CODE LETTER	SAFE STALL TIME IN SECONDS	
NO LOAD			FULL LOAD			LOCKED ROTOR				COLD	HOT
AT 208 VOLT	AT 230 VOLT	AT 460 VOLT	AT 208 VOLT	AT 230 VOLT	AT 460 VOLT	AT 208 VOLT	AT 230 VOLT	AT 460 VOLT			
<b>11.50</b>	<b>13.14</b>	<b>6.57</b>	<b>40.25</b>	<b>36.40</b>	<b>18.20</b>	<b>209.8</b>	<b>232.0</b>	<b>116</b>	<b>G</b>	<b>29</b>	<b>20</b>

TORQUE				INERTIA			ACCEL TIME (DOL)		ALLOWABLE STARTS PER HOUR	
FULL LOAD (lb-ft)	LOCKED ROTOR %FLT	PULL UP %FLT	BREAK DOWN %FLT	ROTOR WR <sup>2</sup> (lb-ft <sup>2</sup> )	NEMA LOAD WK <sup>2</sup> (lb-ft <sup>2</sup> )	MAX ALLOWABLE WK <sup>2</sup> (lb-ft <sup>2</sup> )	NEMA LOAD WK <sup>2</sup> Sec	MAX ALLOWABLE WK <sup>2</sup> Sec	COLD	HOT
<b>67.03</b>	<b>215</b>	<b>180</b>	<b>230</b>	<b>6.823</b>	<b>200</b>	<b>497</b>	<b>5.79</b>	<b>14.10</b>	<b>2</b>	<b>1</b>

APPROVED:	<b>M. PRATER</b>	DRAWING NO.	<b>31057EP0156</b>	REVISION:	<b>1</b>
-----------	------------------	-------------	--------------------	-----------	----------

DATE:  
December 2, 2005

# CONNECTION DIAGRAM

CATALOG NO.:  
EP0156

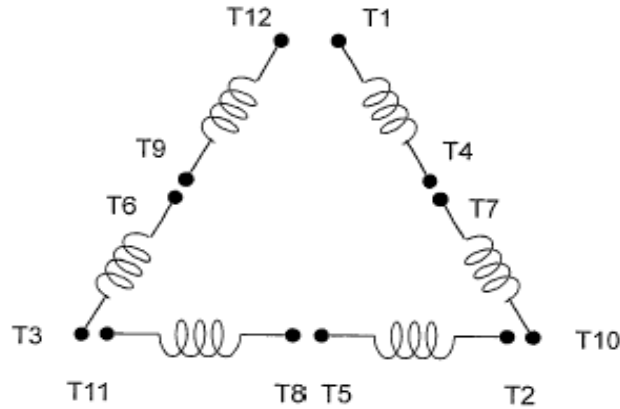

**SCHEMATIC - Δ / Y CONNECTION**

## ACROSS THE LINE CONNECTION

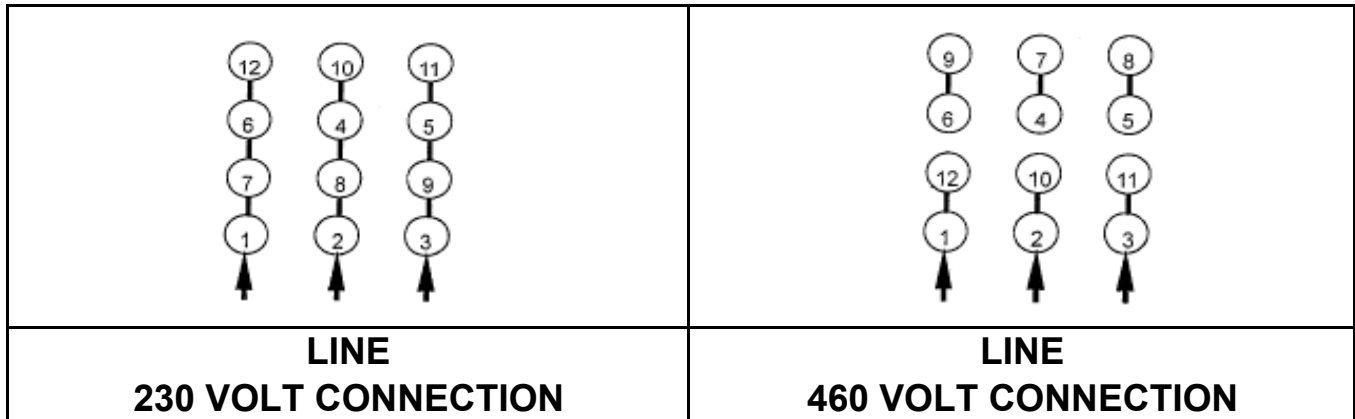

## WYE START-DELTA RUN CONNECTION

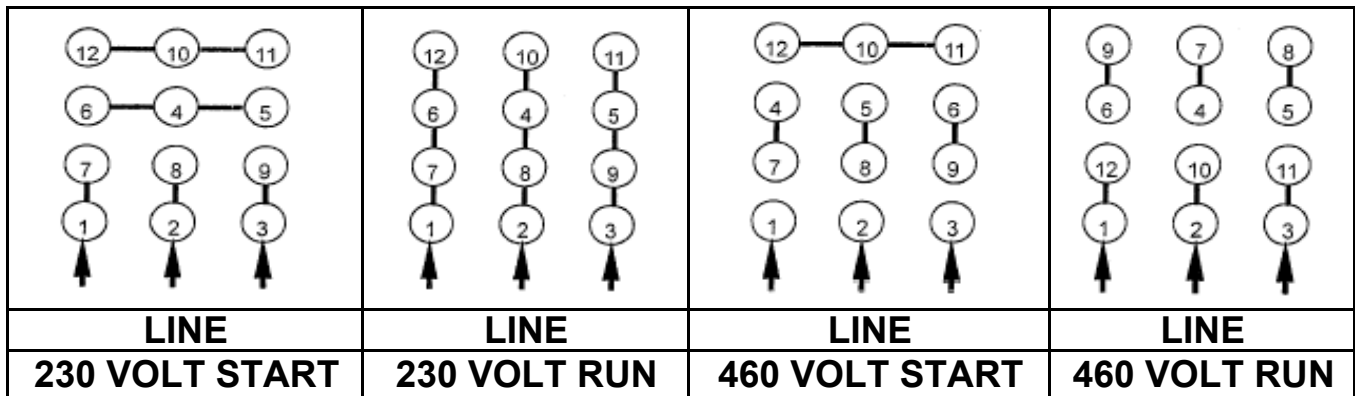

DWG NO.  
**DAC-1565-4**