

DATE
Sept. 25, 2006
Cat. #: EP0156C

OUTLINE DIMENSIONS
3-PHASE INDUCTION MOTOR

MOTOR TYPE:
AEHH8N-CF
FRAME NO. 284TC

Pole	HP	kW	Hz	VOLT	Syn. Speed r/min(rpm)
6	15	11	60	230/560	1200

Ins	Rating	Dimension in	Approx Weight	Bearings
F	CONT.	inches	441 lbs	DE: 6311ZZ NDE: 6310ZZ

Totally Enclosed Fan Cooled Type. Squirrel-cage Rotor.

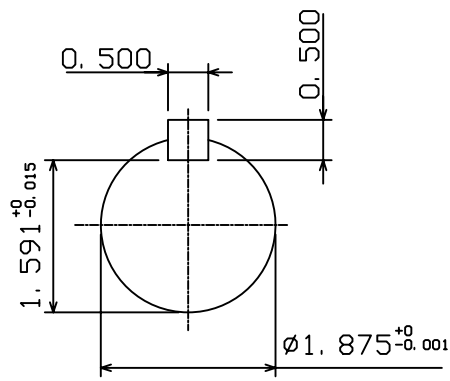
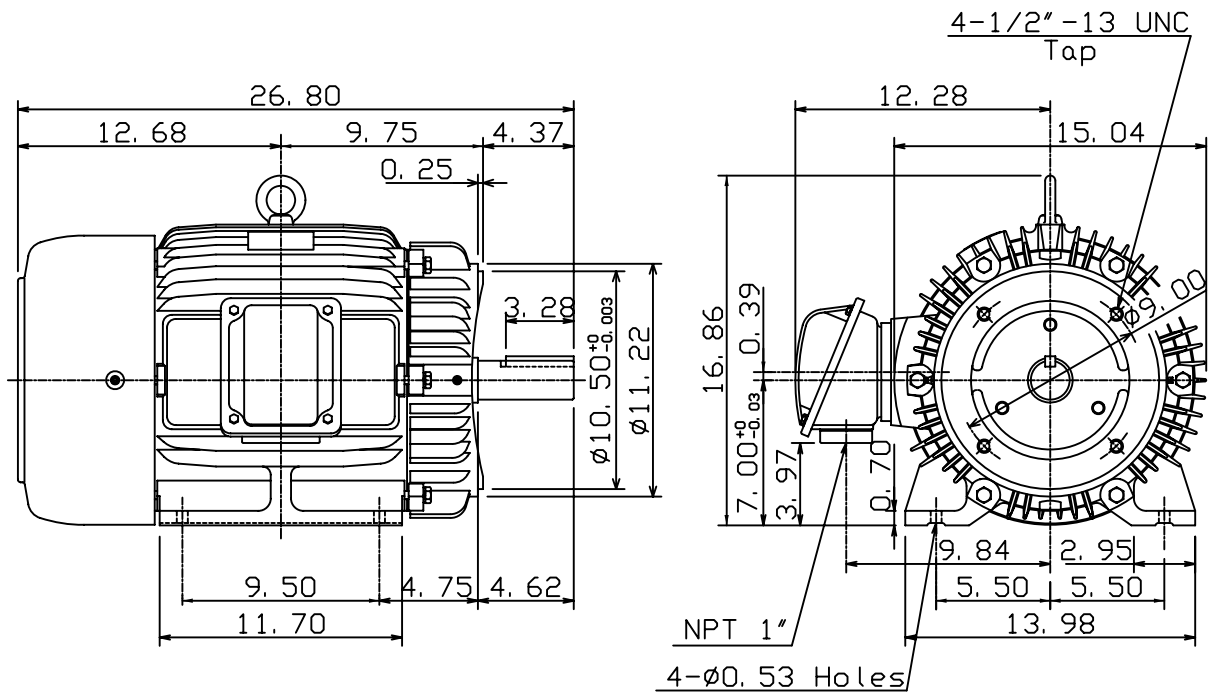

① 01. 10. 05 K. L. KUO

DWN.	K. L. KUO	11-03-04
CHKD.	C. H. KAO	11-04-04
APPD.	M. C. TSAI	11-04-04



DWG NO.
31049J814111

TECO Westinghouse

ISSUED 8/15/2014	PERFORMANCE DATA 3-PHASE INDUCTION MOTOR	ENCLOSURE TEFC
TYPE AEHH8N		CATALOG# EP0156C

NAMEPLATE INFORMATION

OUTPUT		POLE	FRAME SIZE	VOLTAGE	HZ	RATED AMBIENT	INS. CLASS	NEMA DESIGN	TIME RATING	SERVICE FACTOR
HP	KW									
15	11.2	6	284TC	230/460	60	40°C	F	B	CONT.	1.15

VARIABLE FREQUENCY DRIVE SERVICE

VARIABLE TORQUE				OHMS/PHASE EQUIVALENT WYE CIRCUIT (AT RATED OPERATING TEMPERATURE 25°C)				
HZ	HP	RPM	TORQUE (lb-ft)	R1	R2	X1	X2	X _m
3~60	0.0019~15	60~1200	0.166~67.03	0.2865	0.3834	1.2081	2.3238	39.197

CONSTANT TORQUE				CONSTANT HORSEPOWER			
HZ	HP	RPM	TORQUE (lb-ft)	HZ	HP	RPM	TORQUE (lb-ft)
6~60	1.5~15	120~1200	67.03	60~90	15	1200~1800	67.03~44.69

TYPICAL PERFORMANCE

FULL LOAD RPM	EFFICIENCY				POWER FACTOR			SOUND PRESSURE LEVEL @ 3 FT Db(A)
	FULL LOAD		3/4 LOAD %	1/2 LOAD %	FULL LOAD %	3/4 LOAD %	1/2 LOAD %	
	MIN.%	NOM.%						
1175	91	92.4	93	93	83.5	79.5	70.5	64

CURRENTS									NEMA KVA CODE LETTER	SAFE STALL TIME IN SECONDS	
NO LOAD			FULL LOAD			LOCKED ROTOR				COLD	HOT
AT 208 VOLT	AT 230 VOLT	AT 460 VOLT	AT 208 VOLT	AT 230 VOLT	AT 460 VOLT	AT 208 VOLT	AT 230 VOLT	AT 460 VOLT			
11.50	13.14	6.57	40.25	36.40	18.20	209.8	232.0	116	G	29	20

TORQUE				INERTIA			ACCEL TIME (DOL)		ALLOWABLE STARTS PER HOUR	
FULL LOAD (lb-ft)	LOCKED ROTOR %FLT	PULL UP %FLT	BREAK DOWN %FLT	ROTOR WR ² (lb-ft ²)	NEMA LOAD WK ² (lb-ft ²)	MAX ALLOWABLE WK ² (lb-ft ²)	NEMA LOAD WK ² Sec	MAX ALLOWABLE WK ² Sec	COLD	HOT
67.03	215	180	230	6.823	200	497	5.79	14.10	2	1

APPROVED:	M. PRATER	DRAWING NO.	31057EP0156C	REVISION:	1
-----------	------------------	-------------	---------------------	-----------	----------

DATE:
September 13, 2006

CONNECTION DIAGRAM

CATALOG NO.:
EP0156C



SCHEMATIC - Δ / Y CONNECTION

ACROSS THE LINE CONNECTION



WYE START-DELTA RUN CONNECTION

