

DATE	APRIL 1, 2020	OUTLINE DIMENSIONS	MOTOR TYPE:
CATALOG NO.:	EP0306		3-PHASE INDUCTION MOTOR
			FRAME NO. 326T(X)

Pole	HP	kW	Hz	VOLT	r/min(rpm)
6	30	22	60	230/460	1200

Ins	Rating	Dimension in	Approx Weight	Bearings
F	CONT.	inch	① 579 lbs	DE: 6312 NDE: 6310

Totally Enclosed Fan-Cooled Type. Squirrel-cage Rotor.

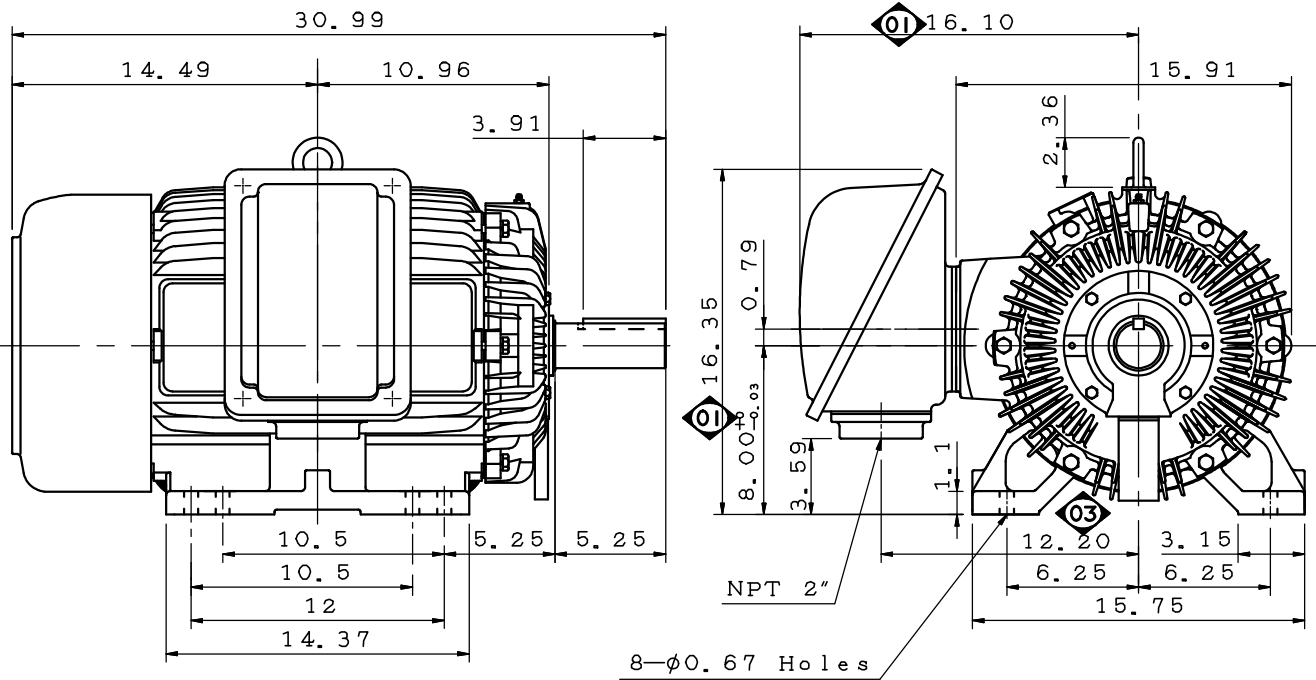

① 12.16.19 Enlarge T-BOX volume. C. T. CHEN

DWG.	J. F. Chen	07.15.19	<b>TECO</b> <b>Westinghouse</b>	DWG NO.
CHKD.	M. C. JENG	07.26.19		31057M097071
APPD.	M. C. JENG	07.26.19		

# TECO Westinghouse

ISSUED <b>07/23/19</b>	<b>PERFORMANCE DATA</b>	ENCLOSURE <b>TEFC</b>
TYPE <b>AEHH8N</b>	<b>3-PHASE INDUCTION MOTOR</b>	CATALOG# <b>EP0306</b>

### NAMEPLATE INFORMATION

OUTPUT		POLE	FRAME SIZE	VOLTAGE	HZ	RATED AMBIEN	INS. CLASS	NEMA DESIGN	TIME RATING	SERVICE FACTOR
HP	KW									
<b>30</b>	<b>22</b>	<b>6</b>	<b>326T(X)</b>	<b>460</b>	<b>60</b>	<b>40°C</b>	<b>F</b>	<b>B</b>	<b>CONT.</b>	<b>1.15</b>

### TYPICAL PERFORMANCE

FULL LOAD RPM	EFFICIENCY				POWER FACTOR			MAXIMUM POWER FACTOR CORRECTION
	FULL LOAD		3/4 LOAD %	1/2 LOAD	F. L. %	3/4 LOAD	1/2 LOAD	
	NOM. %	MIN. %						
<b>1175</b>	<b>93.0</b>	<b>91.7</b>	<b>93.6</b>	<b>93.6</b>	<b>81.5</b>	<b>78.5</b>	<b>71.0</b>	<b>3.51 KVAR</b>

CURRENTS			NEMA KVA CODE LETTER
NO LOAD	FULL LOAD	LOCKED ROTOR	
<b>11.6</b>	<b>37.1</b>	<b>218</b>	<b>G</b>

TORQUE				INERTIA			ACCEL TIME	
FULL LOAD lb-ft	LOCKED ROTOR %FLT	PULL UP %FLT	BREAK DOWN %FLT	ROTOR WR <sup>2</sup> lb-ft <sup>2</sup>	NEMA LOAD WK <sup>2</sup> lb-ft <sup>2</sup>	MAX ALLOWABLE WK <sup>2</sup> lb-ft <sup>2</sup>	NEMA LOAD WK <sup>2</sup> Sec	MAX ALLOWABLE WK <sup>2</sup> Sec
<b>134.05</b>	<b>240</b>	<b>200</b>	<b>250</b>	<b>12.372</b>	<b>384</b>	<b>803</b>	<b>5.09</b>	<b>10</b>

SAFE STALL TIME IN SECONDS		ALLOWABLE STARTS PER HOUR		SOUND PRESSURE LEVEL @ 3 FT dB(A)
COLD	HOT	COLD	HOT	
<b>17</b>	<b>12</b>	<b>2</b>	<b>1</b>	

APPROVED:	<b>D. Lu</b>	DRAWING NO.	<b>31057EP0306</b>	REVISION <b>0</b>
-----------	--------------	-------------	--------------------	-------------------

DATE:  
June 22, 2005

# CONNECTION DIAGRAM

CATALOG NO.:  
EP0306



**SCHEMATIC - Δ / Y CONNECTION**

## ACROSS THE LINE CONNECTION

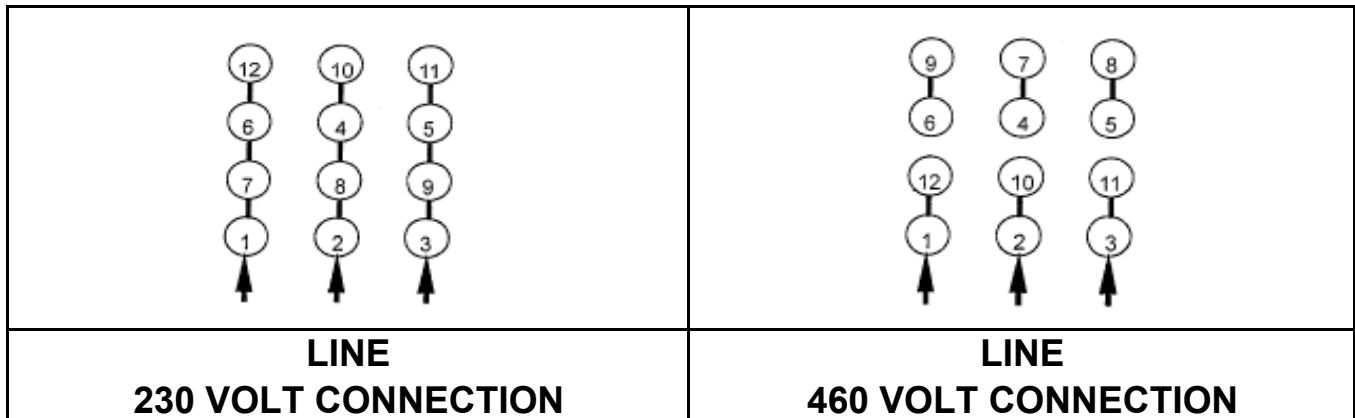

## WYE START-DELTA RUN CONNECTION

